

Federal Energy Regulatory Commission  
Routing Code PJ 11.4  
Washington, DC 20426

Official Business  
Penalty for Private Use



FERC EIS  
No. 0264D



Federal Energy Regulatory Commission  
Office of Energy Projects  
Washington, DC 20426

*Draft Environmental Impact Statement*  
Golden Pass LNG Export Project

***Draft Environmental Impact Statement***  
**FERC EIS 0264D**

Golden Pass LNG Export Project



Docket Nos.  
CP14-517-000  
CP14-518-000

March 2016

March 2016

Docket Nos.:  
CP14-517-000 and CP14-518-000



Cooperating Agencies

FEDERAL ENERGY REGULATORY COMMISSION  
WASHINGTON, D.C. 20426

OFFICE OF ENERGY PROJECTS

In Reply Refer To:  
OEP/DG2E/Gas 2  
Golden Pass Products LLC and  
Golden Pass Pipeline LLC  
Docket Nos. CP14-517-000 and  
CP14-518-000  
Golden Pass LNG Export Project

TO THE PARTY ADDRESSED:

The staff of the Federal Energy Regulatory Commission (FERC or Commission) has prepared a draft environmental impact statement (EIS) for the Golden Pass LNG Export Project, proposed by Golden Pass Products LLC and Golden Pass Pipeline LLC (collectively referred to as Golden Pass) in the above-referenced docket. Golden Pass requests authorization to expand and modify the existing Golden Pass LNG Import Terminal to allow the export of liquefied natural gas (LNG), which would require construction and operation of various liquefaction, LNG distribution, and appurtenant facilities. The Project would also include construction of approximately 2.6 miles of 24-inch pipeline, three new compressor stations, and interconnections for bi-directional transport of natural gas to and from the Golden Pass LNG Export terminal.

The draft EIS assesses the potential environmental effects of the construction and operation of the Golden Pass LNG Export Project in accordance with the requirements of the National Environmental Policy Act (NEPA). The FERC staff concludes that approval of the proposed project, with the mitigation measures recommended in the EIS, would result in some adverse environmental impact; however, those impacts would not be significant with implementation of Golden Pass' proposed mitigation and the additional measures recommended in the draft EIS.

The U.S. Army Corps of Engineers, U.S. Coast Guard (Coast Guard), U.S. Department of Energy, U.S. Department of Transportation, and U.S. Environmental Protection Agency participated as cooperating agencies in the preparation of the EIS. Cooperating agencies have jurisdiction by law or special expertise with respect to resources potentially affected by the proposal and participate in the NEPA analysis. Although the cooperating agencies provided input to the conclusions and recommendations presented in the draft EIS, the agencies will present their own conclusions and recommendations in their respective Records of Decision for the project.

The draft EIS addresses the potential environmental effects of the construction and operation of the following project facilities:

- Liquefaction facilities at the existing Golden Pass Export Terminal including three liquefaction trains, a truck unloading facility, refrigerant and condensate storage, safety and control systems, and associated infrastructure;
- Supply Dock and alternate marine delivery facilities at the Terminal;
- three miles of a new 24-inch-diameter pipeline loop<sup>1</sup> adjacent to the existing Golden Pass pipeline;
- three new compressor stations;
- five new pipeline interconnections and modifications at existing pipeline interconnections; and
- miscellaneous appurtenant facilities.

The FERC staff mailed copies of the draft EIS to federal, state, and local government representatives and agencies; elected officials; environmental and public interest groups; federally-recognized Indian tribes; potentially affected landowners and other interested individuals and groups; newspapers and libraries in the project area; and parties to this proceeding. Paper copy versions of this EIS were mailed to those specifically requesting them; all others received a CD version. In addition, the draft EIS is available for public viewing on the FERC's website ([www.ferc.gov](http://www.ferc.gov)) using the eLibrary link. A limited number of copies are available for distribution and public inspection at:

Federal Energy Regulatory Commission  
Public Reference Room  
888 First Street NE, Room 2A  
Washington, DC 20426  
(202) 502-8371

Any person wishing to comment on the draft EIS may do so. To ensure consideration of your comments on the proposal in the final EIS, it is important that the Commission receive your comments on or before May 16, 2016.

For your convenience, there are four methods you can use to submit your comments to the Commission. The Commission will provide equal consideration to all comments received, whether filed in written form or provided verbally. The Commission encourages electronic filing of comments and has expert staff available to assist you at (202) 502-8258 or [efiling@ferc.gov](mailto:efiling@ferc.gov). Please carefully follow these instructions so that your comments are properly recorded.

---

<sup>1</sup> A pipeline loop is constructed parallel to an existing pipeline to increase capacity.

- 1) You can file your comments electronically using the [eComment](#) feature on the Commission's website ([www.ferc.gov](http://www.ferc.gov)) under the link to [Documents and Filings](#). This is an easy method for submitting brief, text-only comments on a project;
- 2) You can file your comments electronically by using the [eFiling](#) feature on the Commission's website ([www.ferc.gov](http://www.ferc.gov)) under the link to [Documents and Filings](#). With eFiling, you can provide comments in a variety of formats by attaching them as a file with your submission. New eFiling users must first create an account by clicking on “[eRegister](#).” If you are filing a comment on a particular project, please select “Comment on a Filing” as the filing type; or
- 3) You can file a paper copy of your comments by mailing them to the following address. Be sure to reference the project docket number (CP14-517-000 and CP14-518-000) with your submission:

Kimberly D. Bose, Secretary  
Federal Energy Regulatory Commission  
888 First Street NE, Room 1A  
Washington, DC 20426

- 4) In lieu of sending written or electronic comments, the Commission invites you to attend one of the public comment meetings its staff will conduct in the project area to receive comments on the draft EIS, scheduled as follows:

<b>Date and Time</b>	<b>Location</b>
April 19, 2016 7:00 PM	VFW Post 4759 4402 Highway 12 Starks, Louisiana 70661 (337) 743-6409
April 20, 2016 7:00 PM	Sabine Pass ISD 5641 South Gulfway Drive, Sabine Pass, Texas 77655 (409) 971-2321



We will begin our sign up of speakers at 6:00 p.m. The scoping meetings will begin at 7:00 p.m. with a description of our environmental review process by Commission staff, after which speakers will be called. The meetings will end once all speakers have provided their comments or at 10:00 p.m., whichever comes first. If time limits are implemented, they will be strictly enforced to ensure that as many individuals as possible are given an opportunity to comment. The meetings will be recorded by a stenographer to ensure comments are accurately recorded. Transcripts will be entered into the formal record of the Commission proceeding.

Any person seeking to become a party to the proceeding must file a motion to intervene pursuant to Rule 214 of the Commission's Rules of Practice and Procedures (18 CFR Part 385.214).<sup>2</sup> Only intervenors have the right to seek rehearing of the Commission's decision. The Commission grants affected landowners and others with environmental concerns intervenor status upon showing good cause by stating that they have a clear and direct interest in this proceeding which no other party can adequately represent. **Simply filing environmental comments will not give you intervenor status, but you do not need intervenor status to have your comments considered.**

### **Questions?**

Additional information about the project is available from the Commission's Office of External Affairs, at **(866) 208-FERC**, or on the FERC website ([www.ferc.gov](http://www.ferc.gov)) using the eLibrary link. Click on the eLibrary link, click on "General Search," and enter the docket number excluding the last three digits in the Docket Number field (i.e., CP14-517-000 and CP14-518-000). Be sure you have selected an appropriate date range. For assistance, please contact FERC Online Support at [FercOnlineSupport@ferc.gov](mailto:FercOnlineSupport@ferc.gov) or toll free at (866) 208-3676; for TTY, contact (202) 502-8659. The eLibrary link also provides access to the texts of formal documents issued by the Commission, such as orders, notices, and rulemakings.

In addition, the Commission offers a free service called eSubscription that allows you to keep track of all formal issuances and submittals in specific dockets. This can reduce the amount of time you spend researching proceedings by automatically providing you with notification of these filings, document summaries, and direct links to the documents. Go to [www.ferc.gov/docs-filing/esubscription.asp](http://www.ferc.gov/docs-filing/esubscription.asp).

---

<sup>2</sup> See the previous discussion on the methods for filing comments.

**TABLE OF CONTENTS**

**Golden Pass LNG Export Project  
Draft Environmental Impact Statement**

**TABLE OF CONTENTS ..... i**

**LIST OF APPENDICES ..... v**

**LIST OF TABLES ..... vi**

**LIST OF FIGURES ..... viii**

**TECHNICAL ACRONYMS AND ABBREVIATIONS..... x**

**EXECUTIVE SUMMARY ..... ES-1**

**PROPOSED ACTION ..... ES-1**

        Terminal Expansion ..... ES-2

        Pipeline Expansion ..... ES-2

**PUBLIC INVOLVEMENT ..... ES-2**

**PROJECT IMPACTS ..... ES-3**

        Wetlands ..... ES-4

        Land Use and Visual Resources ..... ES-4

        Air Quality and Noise ..... ES-5

        Cumulative Impacts ..... ES-6

**ALTERNATIVES CONSIDERED ..... ES-6**

**CONCLUSIONS ..... ES-7**

**1.0 INTRODUCTION..... 1-1**

    1.1 PROJECT PURPOSE AND NEED ..... 1-2

    1.2 PURPOSE AND SCOPE OF THIS EIS ..... 1-3

        1.2.1 Federal Energy Regulatory Commission ..... 1-4

        1.2.2 U.S. Army Corps of Engineers ..... 1-4

        1.2.3 U.S. Coast Guard ..... 1-5

        1.2.4 U.S. Department of Energy ..... 1-5

        1.2.5 U.S. Department of Transportation ..... 1-6

        1.2.6 U.S. Environmental Protection Agency ..... 1-6

    1.3 PUBLIC REVIEW AND COMMENT ..... 1-6

        1.3.1 Notices and Meetings ..... 1-6

        1.3.2 Scoping Comments ..... 1-7

    1.4 NON-JURISDICTIONAL FACILITIES ..... 1-9

        1.4.1 City of Port Arthur Water Supply Tie-in ..... 1-9

        1.4.2 Truck Transport of Condensate ..... 1-9

    1.5 PERMITS, APPROVALS, AND REGULATORY REVIEWS ..... 1-10

**2.0 PROPOSED ACTION..... 2-1**

    2.1 EXISTING FACILITIES ..... 2-1

        2.1.1 Golden Pass Import Terminal ..... 2-1

        2.1.2 Golden Pass Pipeline ..... 2-6

    2.2 PROPOSED FACILITIES ..... 2-6

        2.2.1 Terminal Expansion ..... 2-6

        2.2.2 Pipeline Expansion ..... 2-13

## TABLE OF CONTENTS

2.3	LAND REQUIREMENTS.....	2-15
	2.3.1 Terminal Expansion.....	2-15
	2.3.2 Pipeline Expansion .....	2-15
2.4	CONSTRUCTION SCHEDULE.....	2-18
2.5	ENVIRONMENTAL COMPLIANCE.....	2-18
	2.5.1 Compliance Monitoring.....	2-19
	2.5.2 Environmental Training.....	2-19
2.6	CONSTRUCTION PROCEDURES.....	2-20
	2.6.1 Terminal Expansion.....	2-20
	2.6.2 Pipeline Expansion .....	2-23
	2.6.3 Special Construction Procedures .....	2-27
	2.6.4 Aboveground Facilities Construction Procedures .....	2-32
	2.6.5 Access Roads.....	2-33
	2.6.6 Pipe Storage and Contractor Yard.....	2-33
2.7	OPERATION, MAINTENANCE, AND SAFETY PROCEDURES .....	2-34
	2.7.1 Terminal Expansion.....	2-34
	2.7.2 Pipeline Expansion .....	2-36
2.8	FUTURE PLANS AND ABANDONMENT .....	2-37
<b>3.0</b>	<b>ALTERNATIVES.....</b>	<b>3-1</b>
3.1	NO-ACTION ALTERNATIVE.....	3-1
3.2	SYSTEM ALTERNATIVES.....	3-2
	3.2.1 Liquefaction Terminal System Alternatives .....	3-2
	3.2.2 Pipeline System Alternatives .....	3-18
3.3	ALTERNATIVE TERMINAL EXPANSION SITES .....	3-18
	3.3.1 Sites in the Vicinity of the Existing Golden Pass Import Terminal.....	3-18
3.4	ALTERNATIVE SUPPLY DOCK SITES .....	3-20
	3.4.1 Golden Pass Import Terminal Existing Ship Slip.....	3-20
	3.4.2 Improvement of the Existing Broussard Dock.....	3-22
	3.4.3 Improvement of Existing Tug Berth.....	3-23
	3.4.4 Conclusion.....	3-23
3.5	ALTERNATIVE TERMINAL CONFIGURATIONS AND POWER SOURCES.....	3-23
	3.5.1 Alternative Terminal Configurations.....	3-23
	3.5.2 Alternative Power Sources.....	3-24
3.6	ALTERNATIVE PIPELINE ROUTES .....	3-25
3.7	ALTERNATIVE PIPELINE EXPANSION ABOVEGROUND FACILITY SITES ...	3-25
	3.7.1 Compressor Station Site Alternatives .....	3-25
	3.7.2 Other Aboveground Facilities.....	3-26
3.8	ALTERNATIVE SITES FOR THE PIPE STORAGE AND CONTRACTOR YARD .....	3-29
3.9	ALTERNATIVE COMPRESSOR STATION DESIGN.....	3-29
	3.9.1 Use of Electric-Powered Compressors and Purchased Power .....	3-29
<b>4.0</b>	<b>ENVIRONMENTAL IMPACT ANALYSIS.....</b>	<b>4-1</b>
4.1	GEOLOGIC CONDITIONS, RESOURCES, HAZARDS, AND MITIGATION DESIGN MEASURES .....	4-1
	4.1.1 Geologic Setting .....	4-1
	4.1.2 Mineral Resources .....	4-3
	4.1.3 Geologic Hazards.....	4-4
	4.1.4 Other Hazards .....	4-8
	4.1.5 Paleontology .....	4-10

## TABLE OF CONTENTS

4.1.6	Design and Construction of the Golden Pass LNG Liquefaction Facility .....	4-10
4.2	SOILS .....	4-12
4.2.1	Soil Types and Limitations .....	4-12
4.2.2	Prime Farmland Soils.....	4-13
4.2.3	Hydric Soils .....	4-14
4.2.4	Compaction Potential.....	4-15
4.2.5	Erosion.....	4-15
4.2.6	Revegetation Potential .....	4-16
4.2.7	Soil Contamination .....	4-17
4.2.8	Corrosion .....	4-18
4.2.9	Requested Modifications to the FERC Plan .....	4-18
4.3	WATER RESOURCES .....	4-22
4.3.1	Groundwater .....	4-22
4.3.2	Surface Water .....	4-29
4.3.3	Alternative Measures to the FERC’s Procedures.....	4-46
4.4	WETLANDS .....	4-47
4.4.1	Existing Environment .....	4-47
4.4.2	Wetland Impacts and Mitigation.....	4-49
4.4.3	Compensatory Mitigation .....	4-53
4.4.4	Conclusion .....	4-54
4.5	VEGETATION.....	4-54
4.5.1	Vegetation Resources .....	4-54
4.5.2	Exotic or Invasive Plant Communities and Noxious Weeds .....	4-60
4.6	WILDLIFE AND AQUATIC RESOURCES .....	4-60
4.6.1	General Wildlife Resources .....	4-60
4.6.2	Unique and Sensitive Wildlife Species.....	4-64
4.6.3	Aquatic Resources .....	4-67
4.6.4	Essential Fish Habitat .....	4-73
4.7	THREATENED AND ENDANGERED SPECIES.....	4-79
4.7.1	Federally Listed Threatened and Endangered Species .....	4-82
4.7.2	State-listed and Other Special-status Species .....	4-85
4.7.3	Threatened and Endangered Species Conclusions.....	4-88
4.8	LAND USE, RECREATION, AND VISUAL RESOURCES .....	4-88
4.8.1	Land Use.....	4-88
4.8.2	Landowner and Easement Requirements.....	4-96
4.8.3	Planned Developments .....	4-97
4.8.4	Recreation and Special Interest Areas .....	4-97
4.8.5	Visual Resources.....	4-98
4.8.6	Coastal Zone Management Program.....	4-101
4.9	SOCIOECONOMICS .....	4-102
4.9.1	Population .....	4-102
4.9.2	Economy and Employment.....	4-104
4.9.3	Local Taxes and Government Revenue .....	4-105
4.9.4	Housing.....	4-107
4.9.5	Public Services.....	4-108
4.9.6	Transportation.....	4-110
4.9.7	Environmental Justice.....	4-111
4.10	CULTURAL RESOURCES .....	4-113
4.10.1	Consultation.....	4-114
4.10.2	Terminal Expansion.....	4-116
4.10.3	Pipeline Expansion .....	4-116

## TABLE OF CONTENTS

4.10.4	Unanticipated Discovery Plan .....	4-116
4.10.5	Compliance with the National Historic Preservation Act.....	4-117
4.11	AIR QUALITY AND NOISE .....	4-117
4.11.1	Air Quality .....	4-117
4.11.2	Noise .....	4-149
4.12	RELIABILITY AND SAFETY .....	4-170
4.12.1	Terminal Expansion.....	4-170
4.12.2	Pipeline Expansion .....	4-228
4.13	CUMULATIVE IMPACTS.....	4-235
4.13.1	Projects and Activities Considered.....	4-240
4.13.2	Potential Cumulative Impacts by Resource .....	4-240
<b>5.0</b>	<b>CONCLUSIONS AND RECOMMENDATIONS.....</b>	<b>5-1</b>
5.1	SUMMARY OF THE ENVIRONMENTAL ANALYSIS.....	5-1
5.1.1	Geologic Resources .....	5-1
5.1.2	Soils .....	5-1
5.1.3	Water Resources .....	5-2
5.1.4	Wetlands .....	5-3
5.1.5	Vegetation.....	5-3
5.1.6	Wildlife and Aquatic Resources .....	5-4
5.1.7	Threatened, Endangered, and Other Special-status Species .....	5-5
5.1.8	Land Use, Recreation, and Visual Resources .....	5-5
5.1.9	Socioeconomics .....	5-6
5.1.10	Cultural Resources.....	5-7
5.1.11	Air Quality and Noise.....	5-7
5.1.12	Safety .....	5-8
5.1.13	Cumulative Impacts .....	5-9
5.1.14	Alternatives.....	5-9
5.2	FERC STAFF'S RECOMMENDED MITIGATION.....	5-10



## LIST OF APPENDICES

APPENDIX A	Distribution List
APPENDIX B	Alignment Sheets
APPENDIX C	HDD Monitoring and Contingency Plan
APPENDIX D	Unanticipated Discovery Plan
APPENDIX E	Summary of Soil Limitations along the Project
APPENDIX F	Spill Prevention, Control, and Countermeasures (SPCC) Plan
APPENDIX G	FERC's Upland Erosion Control, Revegetation, and Maintenance Plan (FERC's Plan)
APPENDIX H	FERC's Wetland and Waterbody Construction and Mitigation Procedures (FERC's Procedures)
APPENDIX I	Dredge Material Management Plan
APPENDIX J	Wetlands Affected by the Construction Operation of the Project
APPENDIX K	Bird Strike Monitoring Plan
APPENDIX L	References
APPENDIX M	List of Preparers

## LIST OF TABLES

<u>Table</u>	<u>Title</u>	<u>Page</u>
1.3-1	Issues Identified and Comments Received during the Public Scoping Period for the Golden Pass LNG Export Project .....	1-8
1.5-1	Major Permits, Approvals, and Consultations for the Golden Pass LNG Export Project.....	1-10
2.3-1	Land Requirements for the Golden Pass LNG Export Project.....	2-16
3.4.2-1	Potential Impacts of the Proposed and Alternative Supply Docks a .....	3-22
3.5.2-1	Comparison of the Fuel Requirements and CO <sub>2</sub> Emissions of the Proposed and Alternative Power Sources .....	3-24
4.1-1	Foreign Pipelines within 0.25 Mile of the Pipeline Expansion .....	4-4
4.2-1	Golden Pass' Requested Deviations from the FERC Plan .....	4-19
4.3-1	Water Requirements for Construction of the Golden Pass LNG Export Project.....	4-27
4.3-2	Watersheds Crossed by the Golden Pass LNG Export Project .....	4-30
4.3-3	Waterbodies Crossed by the Golden Pass LNG Export Project.....	4-31
4.3-4	Golden Pass' Requested Deviations from the FERC Procedures.....	4-38
4.4.1-1	Classifications of Wetlands in the Golden Pass LNG Export Project Area .....	4-48
4.4.1-2	Number of Wetland Crossings by Wetland Type and Crossing Method for the Golden Pass LNG Export Project.....	4-48
4.4.2-1	Wetlands Affected by the Golden Pass LNG Export Project a .....	4-49
4.5-1	Impacts of the Golden Pass LNG Export Project on Vegetation Cover Types .....	4-55
4.6.3-1	Fish Species Occurring in Waterbodies Affected by the Golden Pass LNG Export Project.....	4-68
4.6.3-2	Essential Fish Habitat Species In Waterbodies Affected by the Terminal Expansion .....	4-75
4.7-1	Federally-listed Species Potentially Occurring in the Vicinity of the Golden Pass LNG Export Project .....	4-80
4.7-2	State Special-Status Species Potentially Occurring in the Vicinity of the Golden Pass LNG Export Project.....	4-81
4.8.1-1	Land Uses Affected by the Golden Pass LNG Export Project.....	4-89
4.8.1-2	Proposed Access Roads for the Golden Pass LNG Export Project .....	4-93
4.8.5-1	Major Equipment and Structures for the Terminal Expansion.....	4-99
4.9.1-1	Existing Socioeconomic Conditions in the Golden Pass LNG Export Project Area .....	4-103
4.9.2-1	Employment and Income Characteristics of the Golden Pass LNG Export Project Area.....	4-104
4.9.4-1	Housing Characteristics of the Golden Pass LNG Export Project Area.....	4-107
4.9.5-1	Public Service Data for the Golden Pass LNG Export Project Area.....	4-108
4.9.7-1	Low-Income and Minority Populations in the Golden Pass LNG Export Project Area.....	4-112
4.10.1-1	Golden Pass and SHPO Correspondence for the Golden Pass LNG Export Project.....	4-115
4.11.1-1	National, Texas, and Louisiana Ambient Air Quality Standards .....	4-118
4.11.1-2	Baseline Ambient Air Quality and Ambient Air Quality Standards for the Golden Pass LNG Export Project a .....	4-121
4.11.1-3	Potential-to-Emit for the Golden Pass Import Terminal .....	4-123
4.11.1-4	Major Stationary Source/Major Modification Emission Thresholds .....	4-124
4.11.1-5	Potential-to-Emit for the Terminal Expansion and MP 1 Compressor Station ...	4-125
4.11.1-6	Summary of Construction Emissions by Area Classification for the Golden Pass LNG Export Project .....	4-130
4.11.1-7	Pipeline Expansion Potential-to-Emit .....	4-132

## LIST OF TABLES

4.11.1-8	Summary of Fugitive Emissions during Construction of the Terminal Expansion .....	4-134
4.11.1-9	Summary of Construction Equipment Emissions for the Terminal Expansion...	4-135
4.11.1-10	Summary of Commuting Emissions for the Terminal Expansion.....	4-136
4.11.1-11	Summary of Marine Commuting Emissions .....	4-137
4.11.1-12	Summary of Fugitive Emissions during Construction of the Pipeline Expansion .....	4-138
4.11.1-13	Summary of Construction Equipment Emissions for the Pipeline Expansion ...	4-139
4.11.1-14	Summary of Commuting Emissions for the Pipeline Expansion .....	4-140
4.11.1-15	Significant Impact Analysis for Operation of the Golden Pass Terminal Site ...	4-144
4.11.2-1	Noise Levels of Common Activities .....	4-150
4.11.2-2	Examples of Outdoor Noise Levels.....	4-150
4.11.2-3	Existing Noise Levels at NSAs for the Golden Pass LNG Export Project.....	4-154
4.11.2-4	Noise Levels during Construction of the Terminal Expansion .....	4-159
4.11.2-5	Noise Levels of Typical Construction Equipment at Compressor Stations for the Pipeline Expansion .....	4-159
4.11.2-6	Noise Levels during Construction of Compressor Stations for the Pipeline Expansion .....	4-160
4.11.2-7	Noise Levels during HDD Operations and Construction of the MP 66 Compressor Station .....	4-162
4.11.2-8	Noise Levels during Flare Operations at the Terminal Facility .....	4-164
4.11.2-9	Noise Levels during Operations at the Terminal Expansion and MP 1 Compressor Station .....	4-167
4.11.2-10	Noise Levels during Operations at the MP 33 and MP 66 Compressor Stations .....	4-169
4.12.1-1	Toxicity Levels (in ppm) for Various Exposure Times.....	4-175
4.12.1-2	Flammable Properties.....	4-177
4.12.1-4	LNG Design Spills .....	4-198
4.12.1-5	Mixed Refrigerant, Ethylene, Propane, and Condensate Design Spills .....	4-206
4.12.1-6	Ammonia, Acid Gas, and Condensate Design Spills .....	4-210
4.12.1-7	Maximum Distance to Acute Exposure Guideline Levels (in ppm) for 10-Minute Exposures.....	4-211
4.12.1-8	Thermal Radiation Zones for Impoundment Basins .....	4-224
4.12.2-1	Significant Incidents for Natural Gas Transmission Pipelines (1994 through 2013).....	4-232
4.12.2-2	Significant Incidents for Natural Gas Transmission Pipelines by Outside Forces (1994 through 2013) .....	4-233
4.12.2-3	Annual Average Fatalities Associated with Natural Gas Transmission Pipelines (2009 through 2013) .....	4-234
4.12.2-4	Nationwide Accidental Deaths.....	4-235
4.13.1-1	Past, Present, and Reasonably Foreseeable Actions Considered in the Cumulative Impact Analysis for the Golden Pass LNG Export Project.....	4-236

## LIST OF FIGURES

<u>Figure</u>	<u>Title</u>	<u>Page</u>
2.0-1	General Project Location.....	2-2
2.0-2	Terminal Expansion and MP1 Compressor Station Site Map.....	2-3
2.0-3	Pipeline Expansion Route and MP33 Facilities .....	2-4
2.0-4	Pipeline Expansion Route and MP 63 – 68 Facilities .....	2-5
2.2-1	Terminal Expansion Supply Dock and Surrounding Facilities .....	2-10
2.3-1	Typical Right-of-Way Cross Section Adjacent to Existing Pipeline .....	2-17
2.6-1	Typical Pipeline Construction Sequence.....	2-24
2.6-2	Typical Unsaturated Wetland Crossing.....	2-29
2.6-3	Typical Saturated Wetland Crossing Method.....	2-30
3.2-1	System Alternatives for Liquefaction Terminal.....	3-3
3.3-1	Terminal Expansion Alternative Sites in Upland Areas.....	3-19
3.4-1	Alternative Sites for the Supply Dock.....	3-21
3.7-1	Alternative Sites for the MP 33 Compressor Station .....	3-27
3.7-2	Alternative Sites for the MP 66 Compressor Station .....	3-28
4.1-1	Geologic Resources in the Vicinity of the Project .....	4-2
4.11.2-1	NSAs for the MP 1 Compressor Station and Terminal Expansion .....	4-153
4.11.2-2	NSAs for the MP 33 Compressor Station .....	4-156
4.11.2-3	NSAs for the MP 66 Compressor Station and Calcasieu Loop HDD Entry/Exit .....	4-157
4.12.1-1	Maximum Flammable Vapor Dispersion from LNG Scenarios 12, 20, 83 and 211(1) AND 211(2).....	4-199
4.12.1-2	Maximum Flammable Vapor Dispersion from LNG Scenario 52 Released Horizontally toward the South .....	4-200
4.12.1-3	Maximum Flammable Vapor Dispersion for LNG Scenario 52 Released Horizontally to the North .....	4-201
4.12.1-4	Maximum Flammable Vapor Dispersion from LNG Scenario 52 Released Vertically near the Northern End of the Rundown Line .....	4-202
4.12.1-5	Maximum Flammable Vapor Dispersion from LNG Scenario 52 Released Vertically near the Southeastern End of the Rundown Line .....	4-203
4.12.1-6	Maximum Flammable Vapor Dispersion from a Full Release from the LNG Liquefaction Rundown Line.....	4-204
4.12.1-7	Maximum Flammable Vapor Dispersion from a Full Release from the LNG Storage Tank Withdrawal Header Design Spill .....	4-205
4.12.1-8	Maximum Flammable Vapor Dispersion from Ethylene and Mixed Refrigerant Design Spills .....	4-207
4.12.1-9	Maximum Flammable Vapor Dispersion from Propane Design Spills.....	4-208
4.12.1-10	Maximum Flammable Vapor Dispersion from Hydrocarbon Condensate Design Spills .....	4-209
4.12.1-11	Maximum Distances to AEGL-1 for Ammonia Design Spills.....	4-212
4.12.1-12	Maximum Distances to AEGL-1 for Hydrogen Sulfide in the Acid Gas Design Spill .....	4-213
4.12.1-13	Maximum Distances to AEGL-1 for Toluene in the Condensate Design Spills.	4-214
4.12.1-14	Maximum Distances to AEGL-1 for Benzene in the Condensate Design Spills.....	4-215
4.12.1-15	Maximum Extent of 1 psi from Ethylene and Two Mixed Refrigerant Overpressure Scenarios .....	4-217
4.12.1-16	Maximum Extent of 1 psi from Propane Overpressure Scenarios .....	4-218
4.12.1-17	Maximum Extent of 1 psi from Condensate Overpressure Scenarios .....	4-219
4.12.1-18	Maximum Extent of 1 psi from Condensate Overpressure Scenarios at the Southwest Corner of the Liquefaction Area.....	4-220

## LIST OF FIGURES

4.12.1-19	Maximum Extent of 1 psi from Mixed Refrigerant Scenario MR-136 from the Congested Area of Train 1 nearest to the LNG Storage Tanks .....	4-221
4.12.1-20	Maximum Extent of 1 psi from Mixed Refrigerant Scenario MR-136 in the Congested Area Nearest to the Property Line .....	4-222
4.12.1-21	Maximum Distance to Thermal Radiation Levels from Impoundment Sumps...	4-225
4.12.1-22	Maximum Distance to 1,600 Btu/ft <sup>2</sup> -hr from Jet Fires from the LNG Design Spills.....	4-226



## TECHNICAL ACRONYMS

ACHP	Advisory Council on Historic Preservation
AEGL	Acute Exposure Guideline Level
Annova LNG	Annova LNG Common Infrastructure, LLC
APE	area of potential effect
API	American Petroleum Institute
AQCR	Air Quality Control Region
ASCE	American Society of Civil Engineer
ASME	American Society of Mechanical Engineers
ATWS	additional temporary workspace
BA	Biological Assessment
BACT	Best Available Control Technology
BCC	Birds of Conservation Concern
bcf/d	billion cubic feet per day
BCR	Bird Conservation Region
BLEVE	boiling-liquid-expanding-vapor-explosion
BMP	best management practices
BOG	boil off gas
BPA	Beaumont-Port Arthur area
BPVC	Boiler and Pressure Vessel Code
BST	Baker-Strehlow-Tang
C5+	pentane and heavier
CAA	Clean Air Act
Cameron LNG	Cameron LNG, LLC
CAMx	Comprehensive Air Quality Model with Extensions
CE FLNG	CE FLNG, LLC
CEQ	Council on Environmental Quality
CFR	Code of Federal Regulations
CH <sub>4</sub>	methane
Cheniere	Corpus Christi; Cheniere Energy
Cheniere Energy	Cheniere Energy Partners, L.P.
CI ICE	Compression Ignition Internal Combustion Engines
CMP	Coastal Management Program
CO	carbon monoxide
CO <sub>2</sub>	carbon dioxide
CO <sub>2</sub> -eq	carbon dioxide equivalents
Coast Guard	U.S. Coast Guard
COE	U.S. Army Corps of Engineers
Commission	Federal Energy Regulatory Commission
COTP	Captain of the Port
CPT	cone penetration test
CWA	Clean Water Act

## TECHNICAL ACRONYMS

CZMA	Coastal Zone Management Act
CZMP	Coastal Zone Management Program
dB	decibels
dBA	A-weighted decibel
DDT	dichlorodiphenyltrichloroethane
Delfin	Delfin LNG, LLC
DMMP	Dredged Material Management Plan
DMPA	dredged material placement area
DOD	U.S. Department of Defense
DOE	U.S. Department of Energy
DOE/FE	Department of Energy, Office of Fossil Energy
DOT	U.S. Department of Transportation, Pipeline and Hazardous Materials Safety Administration
DWU	Drinking Water Utility
EF	emission factor
EFH	essential fish habitat
EI	environmental inspector
EIS	Environmental Impact Statement
EO	Executive Order
Eos	Eos LNG, LLC
EPA	U.S. Environmental Protection Agency
EPAct 2005	Energy Policy Act of 2005
ERP	Emergency Response Plan
ERPG	Emergency Response Planning Guidelines
ESA	Endangered Species Act
Excelerate	Excelerate Liquefaction Solutions, LLC
FAA	Federal Aviation Authority
FE	Office of Fossil Energy
FEED	front-end-engineering-design
FEMA	Federal Emergency Management Agency
FERC	Federal Energy Regulatory Commission
FGT	Florida Gas Transmission Company, LLC
FLEX	Freeport LNG Expansion, LP and FLNG Liquefaction, LLC (collectively)
FLNGV	floating liquefaction and storage vessel
FLSO	floating liquefaction, storage, and offloading
Freeport LNG	Freeport LNG Development, LP
ft <sup>3</sup>	cubic feet
FTA	Free Trade Agreement
FWS	U.S. Fish and Wildlife Service
G2 LNG	G2 LNG, LLC
Gasfin	Gasfin Development USA, LLC

## TECHNICAL ACRONYMS

GCD	Groundwater Conservation District
GHG	Greenhouse Gas
GMFMC	Gulf of Mexico Fishery Management Council
gpm	gallons per minute
GPP	Golden Pass Products, LLC
GPPL	Golden Pass Pipeline LLC
Gulf Coast	Gulf Coast LNG Exports, LLC
Gulf LNG	Gulf LNG Energy, LLC
GWP	global warming potential
H <sub>2</sub> S	hydrogen sulfide
HAP	Hazardous Air Pollutant
HAZID	hazard identification
HAZOP	hazard and operability review
HCA	high-consequence area
HDD	Horizontal Directional Drilling
HGB	Houston-Galveston-Brazoria area
HMI	human machine interfaces
hp	horsepower
HRA	HRA Gray & Pape, LLC
IPCC	Intergovernmental Panel on Climate Change
ISA	International Society for Automation
km	kilometer
KMLP	Kinder Morgan Louisiana Pipeline LLC
kTon/yr	kilotons per year
kV	kilovolt
LAC	Louisiana Administrative Code
lbs/hr	pounds per hour
LDEQ	Louisiana Department of Environmental Quality
L <sub>dn</sub>	day-night sound level
LDWF	Louisiana Department of Wildlife and Fisheries
L <sub>eq(24)</sub>	24-hour equivalent sound level
LFL	lower flammable limit
LDNR	Louisiana Department of Natural Resources
LNG	liquefied natural gas
LOR	Letter of Recommendation
Louisiana LNG	Louisiana LNG Energy, LLC
m	meter
m/sec	meter per second
m <sup>3</sup>	cubic meter
Magnolia	Magnolia LNG
MAOP	maximum allowable operation pressure

## TECHNICAL ACRONYMS

MARAD	DOT's Marine Administration
MBTA	Migratory Bird Treaty Act
MBTU/hr	1,000 British thermal units per hour
Memorandum	Memorandum of Understanding on Natural Gas Transportation Facilities
Mgal/day	million gallons per day
MLV	mainline valve
MMBtu/hr	Million British thermal units per hour
MOF	marine offloading facility
MOU	Memorandum of Understanding
MP	milepost
MR	Mixed Refrigerant
MSFCMA	Magnuson-Stevens Fishery Conservation and Management Act
MSL	mean sea level
MSS	maintenance, startup, and shutdown
mtpy	metric tons per year
MTSA	Maritime Transportation Security Act of 2002
MW	megawatt
N <sub>2</sub> O	nitrous oxide
NAAQS	National Ambient Air Quality Standards
NAVD 88	North American Vertical Datum of 1988
NEPA	National Environmental Policy Act of 1969
NESHAP	National Emissions Standards for Hazardous Air Pollutant
NextDecade	NextDecade, LLC
NFPA	National Fire Protection Association
NGA	Natural Gas Act
NGPL	Natural Gas Pipeline Company of America
NHPA	National Historic Preservation Act
NO <sub>2</sub>	nitrogen dioxide
NOAA	National Oceanic and Atmospheric Administration
NOAA Fisheries	National Marine Fisheries Service
NOI	Notice of Intent to Prepare an Environmental Document for the Planned Golden Pass LNG Export Project and Golden Pass Export Pipeline Project, Request for Comments on Environmental Issues, and Notice of Public Scoping Meeting
NO <sub>x</sub>	nitrogen oxides
NPDES	National Pollutant Discharge Elimination System
NRCS	Natural Resource Conservation Service
NRHP	National Register of Historic Places
NSA	Noise Sensitive Area
NSPS	New Source Performance Standards
NSR	New Source Review
NWI	National Wetlands Inventory

## TECHNICAL ACRONYMS

O <sub>2</sub>	oxygen
O <sub>3</sub>	ozone
OBE	Operating Basis Earthquake
OEP	Office of Energy Projects
°F	Fahrenheit
OPS	Office of Pipeline Safety
OSHA	Occupational Safety and Health Administration
P&ID	Piping and Instrumentation Diagrams
Pb	lead
PCB	polychlorinated biphenyls
PCL	protective concentration level
PEM	palustrine emergent
PEMf	palustrine farmed
PEMx	palustrine emergent excavated
PFO	palustrine forested
PFOx	palustrine forested excavated
PHMSA	Pipeline and Hazardous Materials Safety Administration
Pipeline Expansion Plan	Golden Pass Export Pipeline Expansion FERC's Upland Erosion Control, Revegetation, and Maintenance Plan
PM <sub>10</sub>	particulate matter with an aerodynamic diameter less than or equal to 10 microns
PM <sub>2.5</sub>	particulate matter with an aerodynamic diameter less than or equal to 2.5 microns
Port Arthur	Port Arthur LNG
ppb	part(s) per billion
ppm	part(s) per million
ppmv	parts per million by volume
ppmvd	parts per million, volumetric dry
PRM Plan	Permittee Responsible Mitigation Plan
Procedures	FERC's Wetland and Waterbody Construction and Mitigation Procedures
Project	Golden Pass LNG Export Project
PSD	Prevention of Significant Deterioration
psig	pounds per square inch gauge
PSM	Process Safety Management of Highly Hazardous Chemicals
PSS	palustrine scrub-shrub
PTE	potential-to-emit
PUB	palustrine unconsolidated bottom
PVC	polyvinyl chloride
PWL	sound power level
RCC	Railroad Commission of Texas
RICE	Reciprocating Internal Combustion Engines



## TECHNICAL ACRONYMS

Rio Grande LNG	Rio Grande LNG, LLC
RPT	rapid phase transition
RV	recreational vehicle
SCT&E	SCT&E LNG, LLC
Secretary	Secretary of the Commission
SEP	surface emissive power
SH	State Highway
SHPO	State Historic Preservation Officer
SI ICE	Spark Ignition Internal Combustion Engines
SIL	significant impact level
SIP	State Implementation Plan
SLOSH	Sea, Lake and Overland Surges hydrodynamic model
SNND	Sabine Neches Navigation District
SNWW	Sabine Neches Waterway
SO <sub>2</sub>	sulfur dioxide
SPCC Plan	Spill Prevention, Control and Countermeasure Plan
SPL	sound pressure level
SSE	Safe Shutdown Earthquake
SSURGO	Soil Survey Geographic Database
SWPPP	Stormwater Pollution Prevention Plan
TAC	Texas Administrative Code
TCEQ	Texas Commission on Environmental Quality
Tejas	Kinder Morgan Tejas Pipeline LLC
TEMA	Tubular Exchanger Manufacturers Association
Terminal Expansion	Golden Pass Export Terminal Expansion
TETCO	Texas Eastern Transmission Company, LP
Texas LNG	Texas LNG, LLC
Texoma	Texoma Pipeline Company
TGLO	Texas General Land Office
TGP	Tennessee Gas Pipeline
TPWD	Texas Parks and Wildlife Department
tpy	tons per year
Transco	Transcontinental Gas Pipe Line Company, LLC
Trunkline LNG	Trunkline LNG Company, LLC
TSP	total suspended particulates
TWDB	Texas Water Development Board
UDP	Unanticipated Discovery Plan
UFL	upper flammability limit
USC	United States Code
USGCRP	U.S. Change Research Program
USGS	U.S. Geological Survey

## TECHNICAL ACRONYMS

Venture Global	Venture Global Calcasieu Pass, LLC
VOC	volatile organic compounds
Waller Point	Waller Point LNG
WMA	wildlife management area
WSA	Waterway Suitability Assessment
yd <sup>3</sup>	cubic yard
µg	micrograms

## EXECUTIVE SUMMARY

The staff of the Federal Energy Regulatory Commission (FERC or Commission) prepared this draft Environmental Impact Statement (EIS) to assess the environmental impacts associated with construction and operation of facilities proposed by Golden Pass Pipeline, LLC (GPPL) and Golden Pass Products, LLC (GPP). The EIS was prepared in accordance with the requirements of the National Environmental Policy Act of 1969 (NEPA) and the Commission's implementing regulations under Title 18 of the Code of Federal Regulations, Part 380 (18 CFR 380). On July 7, 2014, GPP filed an application with the FERC in Docket No. CP14-517-000 pursuant to Section 3(a) of the Natural Gas Act (NGA) and Part 153 of the Commission's regulations. On July 7, 2014, GPPL filed an application with the FERC in Docket No. CP14-518-000 under Section 7 of the NGA, as amended, and Parts 157 and 284 of the Commission's regulations. The combined GPP and GPPL actions and facilities are referred to as the Golden Pass LNG Export Project (Project), which consists of the Golden Pass Export Terminal Expansion (Terminal Expansion) and the Golden Pass Export Pipeline Expansion (Pipeline Expansion). The applicants are collectively referred to in this document as Golden Pass.

Golden Pass proposes to construct and operate onshore natural gas liquefaction and associated facilities to allow the export of liquefied natural gas (LNG) in Texas, and to construct, own, operate, and maintain a new interstate natural gas pipeline, three new compressor stations, and ancillary facilities in Texas and Louisiana.

The purpose of the EIS is to inform the FERC decision makers, the public, and the permitting agencies about the potential adverse and beneficial environmental impacts of the proposed Project and its alternatives, and recommend mitigation measures that would reduce adverse impacts to the extent practicable. We<sup>1</sup> prepared our analysis based on information provided by Golden Pass and further developed from data requests; field investigations; scoping; literature research; and contacts with or comments from federal, state, and local agencies, Native American tribes, and individual members of the public.

The FERC is the federal agency responsible for authorizing interstate natural gas transmission facilities under the NGA and is the lead federal agency for the preparation of this EIS in compliance with the requirements of NEPA. The U.S. Army Corps of Engineers (COE); U.S. Coast Guard (Coast Guard); U.S. Department of Energy; U.S. Department of Transportation, Pipeline and Hazardous Materials Safety Administration; and U.S. Environmental Protection Agency are cooperating agencies for development of this EIS consistent with 40 CFR 1501.6(b). A cooperating agency has jurisdiction by law or has special expertise with respect to environmental resource issues associated with the Project.

## PROPOSED ACTION

According to Golden Pass, the Project would transport and liquefy domestic natural gas into LNG for export, and deliver competitively priced LNG to foreign markets.

Golden Pass designed its Project to meet each of the following purposes:

- enable bi-directional flow of natural gas along the Golden Pass Pipeline system and allow natural gas to be received from domestic sources;

---

<sup>1</sup> "We," "us," and "our" refer to the environmental staff of the FERC's Office of Energy Projects.

- expand the existing Golden Pass Import Terminal to receive, treat, and liquefy domestic natural gas for export from the existing marine facility; and
- load LNG into vessels berthed at the existing marine facility to transport LNG worldwide.

### **Terminal Expansion**

Golden Pass would construct the Terminal Expansion on a 919-acre site along State Highway 87 and the Sabine Neches Waterway, about 2 miles north of the community of Sabine Pass, Texas. The proposed site is south of, east of, and partially within the existing terminal fence line in Jefferson County, Texas. The Terminal Expansion would include the following facilities:

- feed gas pre-treatment facilities, including a mercury removal system, an amine system for removal of carbon dioxide and hydrogen sulfide followed by molecular sieve dehydration, and a heavy hydrocarbon (pentane and heavier [C5+]) removal system;
- three liquefaction trains (with associated power supply), each with a liquefaction capacity of 5.2 million metric tons per year (14,247 metric tons per day) of LNG for export;
- liquefaction facility utilities and associated systems;
- a truck loading/unloading area;
- refrigerant make-up and condensate product storage tanks; and
- a supply dock (referred to as a marine offloading facility [MOF] in the Application to the FERC).

### **Pipeline Expansion**

Golden Pass proposes to construct and operate about 2.6 miles of 24-inch-diameter pipeline between mileposts (MP) 63 and 66 of the existing Golden Pass Pipeline; three new compressor stations (MP 1 Compressor Station, MP 33 Compressor Station, and MP 66 Compressor Station); and associated facilities in Jefferson and Orange Counties, Texas, and Calcasieu Parish, Louisiana. Construction of the pipeline and associated facilities would affect a total of about 99 acres of land, with operation affecting a total of about 56 acres. The pipeline would extend from an interconnection with a surface facility operated by Tennessee Gas Pipeline (TGP) near MP 63 of the existing Golden Pass Pipeline to a new compressor station near a surface facility operated by Texas Eastern Transmission Company, LP (TETCO) near MP 66. Golden Pass would modify existing interconnections and metering facilities associated with other pipeline systems, including Natural Gas Pipeline Company of America (MP 1), Texoma Pipeline Company (MP 33), TGP (MP 63), TETCO (MP 66), and Transcontinental Gas Pipe Line Company, LLC (MP 68.5) systems; and construct and operate associated facilities, including pig receivers and launchers<sup>2</sup> and mainline valves.

## **PUBLIC INVOLVEMENT**

On May 16, 2013, Golden Pass filed a request with the FERC to use our pre-filing review process. This request was approved on May 30, 2013. Pre-filing Docket No. PF13-14-000 was established for the Project to place information filed by Golden Pass and related documents issued by the FERC into the public record. Golden Pass held public open houses in Starks, Louisiana, on July 29, 2013; Sabine Pass, Texas, on July 30, 2013; and Vidor, Texas, on August 1, 2013. The FERC staff participated in those meetings to

---

<sup>2</sup> A pipeline “pig” is an internal device to clean or inspect the pipeline. A pig launcher/receiver is an aboveground facility where pigs are inserted into or retrieved from the pipeline.

describe the FERC process and provide those attending with information on how to file comments with the FERC.

On September 19, 2013, the FERC issued a *Notice of Intent to Prepare an Environmental Assessment for the Planned Golden Pass LNG Export Project and Golden Pass Export Pipeline Project, Request for Comments on Environmental Issues, and Notice of Public Scoping Meeting*. This notice was sent to about 560 interested parties, including federal, state, and local officials; agency representatives; conservation organizations; Native American tribes; local libraries and newspapers in the Project area; and property owners in the vicinity of planned Project facilities. On October 2 and 3, 2013, we conducted public scoping meetings in Starks, Louisiana, and Sabine Pass, Texas, to provide an opportunity for the public to learn more about the Project and provide comments on environmental issues to be addressed in the EIS.

In addition, in July 2013 and June 2014, the FERC staff visited the existing Golden Pass Import Terminal, the proposed Terminal Expansion site, the proposed Pipeline Expansion route, and the proposed sites of the new compressor stations.

Through the scoping and agency comment process, we received comments on a variety of environmental issues. We continued to receive and consider public comments during the entire pre-filing period and throughout development of this EIS. Substantive environmental issues identified through this public review process are addressed in this EIS. The transcripts of the public scoping meeting and all written comments are part of the FERC's public record for the Terminal Expansion and Pipeline Expansion, and are available for viewing under the Project pre-filing docket number<sup>3</sup> and the application docket numbers.<sup>4</sup>

A copy of the draft EIS was mailed to federal, state, and local government agencies; elected officials; Native American tribes; local libraries and newspapers; intervenors to the FERC's proceeding; and other interested parties (i.e., landowners, miscellaneous individuals, and environmental groups that provided scoping comments).

## **PROJECT IMPACTS**

We evaluated the potential impacts of construction and operation of the Project on geology; soils; water use and quality; wetlands; vegetation; wildlife, aquatic resources, and essential fish habitat; threatened, endangered, and special-status species; land use, recreation, and visual resources; socioeconomics; cultural resources; air quality and noise; and reliability and safety—as well as cumulative impacts. Where necessary, we are recommending additional mitigation to minimize or avoid these impacts. Section 5 of the EIS contains a compilation of our recommendations.

Overall, construction of Project facilities would disturb about 1,017 acres of land and open water, and operation of the Project would disturb 838 acres. For the land not used permanently to operate the Project, Golden Pass would allow the remaining land disturbed during construction to return to pre-construction conditions and uses.

Construction of the Terminal Expansion would result in impacts on 918.7 acres of open land, industrial/commercial land, forested and non-forested wetlands, and open water; of which about 783 acres

---

<sup>3</sup> Transcripts of the public scoping meetings for the Project (Docket No. PF13-14-000, Accession Nos. 20131018-4006 and 20131018-4005) are available on the FERC website at <http://ferc.gov/docs-filing/elibrary.asp>.

<sup>4</sup> Comments submitted after the Project applications were filed with the FERC are part of the public record for the Terminal Expansion (Docket No. CP14-517-000) and Pipeline Expansion (Docket No. CP14-518-000), and are available on the FERC website at <http://ferc.gov/docs-filing/elibrary.asp>.



would be permanently impacted. The entire 2.6 miles of pipeline right-of-way would be collocated with the existing Golden Pass Pipeline right-of-way. Construction of the Pipeline Expansion would affect forested, scrub-shrub, and emergent wetlands; upland forest and planted pine forest; open space; open water; industrial land; and agricultural land—but we conclude that the impacts would not be significant with implementation of our recommendations and agency-approved wetland compensation.

Based on our analysis, scoping, and agency consultations, the major issues are impacts on wetlands, visual resources, air quality, and noise, and cumulative impacts.

## **Wetlands**

Construction of the Terminal Expansion would affect a total of 381.4 acres of wetlands; 372.5 acres would be permanently filled during operation of the Terminal Expansion. The remaining 8.9 acres would be allowed to revert to pre-construction conditions. Golden Pass would offset impacts on COE jurisdictional wetlands through mitigation measures included in its *Draft Compensatory Mitigation Plans for the Golden Pass Products LNG Export Project*. The mitigation measures include restoration of offsite coastal wetland habitat and acquisition of credits at a COE-approved wetland mitigation bank. Because the compensatory mitigation plans have not been finalized, we are recommending that Golden Pass file final compensatory wetland mitigation plans developed in consultation with federal and state agencies. Construction and operation of the Pipeline Expansion would affect about 17.0 acres of wetlands, of which 11.4 acres would be permanently disturbed. The remaining emergent and scrub-shrub wetlands would be temporarily affected because the vegetation would return to a community that would function similarly to the pre-construction community. Although less than 0.1 acre of forested wetlands along the pipeline construction right-of-way would be cleared for construction of the Project, this would result in a long-term impact because of the slow growth rate of trees. Golden Pass would implement the mitigation measures in the FERC's *Wetland and Waterbody Construction and Mitigation Procedures* to control erosion and restore the grade and hydrology after construction in wetlands.

## **Land Use and Visual Resources**

A portion of the Terminal Expansion site is within the designated coastal zone, which is managed by the Texas Railroad Commission through the Texas Coastal Management Program (CMP). The boundaries of the state's coastal zone include all or parts of 18 coastal counties, including Jefferson County. The purpose of the Texas CMP is to manage designated coastal natural resource areas. The Texas Railroad Commission conducts consistency reviews for projects authorized by federal or state agencies. Golden Pass submitted its application and request for consistency review to the Texas Railroad Commission on July 7, 2014. We are recommending that Golden Pass file documentation of concurrence from the Texas Railroad Commission that the Project is consistent with the Texas CMP.

The expanded terminal would include many aboveground structures that could result in a visual resource impact. These include three liquefaction trains, a supply dock, six marine dolphins, new buildings and infrastructure, and one ground flare. In addition, most of these structures would require lighting. Golden Pass would site a portion of the Terminal Expansion within the existing Golden Pass Import Terminal site and would construct the remaining portions adjacent to the existing terminal to the south and east. The existing terminal includes outdoor lighting that consists primarily of downlighting for safety and lights on tall structures for aircraft warnings. Golden Pass would use similar lighting on the expanded terminal during operation. In addition, viewers may be able to see the ground flare at night when in use; however, nighttime usage of the ground flare would only occur occasionally. The viewshed for the expanded terminal extends as far as 5.0 miles from the site. Most of the viewers of night lights in that area would consist of residents of Pleasure Island, boaters in the waterway, and viewers from a variety of recreational locations in the viewshed. Since additional lighting at the facility would be similar to the existing lighting in the area, we conclude that impacts from facility lighting would not be significant.

## Air Quality and Noise

Most Project-related air emissions would be produced by operation of the expanded LNG terminal and the compressor stations; Golden Pass would comply with all applicable air permit requirements for those facilities. Construction of the Project would also create emissions from fossil-fueled construction equipment and fugitive dust. Such air quality impacts would generally be temporary and localized. Golden Pass has not provided specific mitigation measures to control dust during construction; therefore, we are recommending that Golden Pass file a Fugitive Dust Control Plan. The Project is generally located in attainment areas; however, the delivery of equipment and facilities by marine vessels would pass through the Houston-Galveston-Brazoria area which is classified a marginal nonattainment area for the 2008 8-hour ozone standard. We conducted a General Conformity applicability determination for the estimated emissions from the marine operations through the Houston-Galveston-Brazoria area. The marine operations emissions would not exceed the general conformity determination thresholds for nitrogen oxides or volatile organic compounds (both precursors for ozone) and General Conformity would not apply to the Project. With implementation of our recommendation for a Fugitive Dust Control Plan, we would not expect construction equipment emissions to cause or significantly contribute to a violation of an applicable air quality standard.

Long-term impacts on air quality would result from operation of the Terminal Expansion facilities and the compressor stations. Golden Pass would minimize potential impacts on air quality caused by operation of the Terminal Expansion and MP 1 Compressor Station by adhering to applicable federal and state regulations and installing best available control technology to minimize emissions. The Air Quality Permit 116055 and the Prevention of Significant Deterioration Air Quality Permit PSDTX1386 for the Terminal Expansion and MP 1 Compressor Station were issued by the TCEQ on January 16, 2015, authorizing construction and operation of the Terminal Expansion. The minor New Source Review permit and Title V operating permit for the MP 66 Compressor Station would be issued by the Louisiana Department of Environmental Quality. Golden Pass anticipates filing their minor NSR permit application for the MP 33 Compressor Station no later than the first quarter of 2016 to ensure that the required permit would be obtained within 18 months of construction, as required by the TCEQ air permitting regulations. It is expected that compliance with the applicable state and federal air quality standards and regulations would be addressed accordingly in the corresponding permit applications and issued permits.

Operation of the expanded terminal would generate sound levels throughout the life of the Project, but the increase in noise levels would be just above the “barely detectable” noise level increase of 3 A-weighted decibels (dBA) and would result in minor impacts on the nearest noise-sensitive area (NSA). In addition, the noise level would be slightly above the FERC limit of a day-night sound level ( $L_{dn}$ ) of 55 dBA. Golden Pass has agreed to implement several noise mitigation measures at the Terminal Expansion and MP 1 Compressor Station. In addition, we are recommending that Golden Pass file a full-load noise survey no later than 60 days after each liquefaction train is put in service for the first and second liquefaction trains. If noise levels attributable to operation of the Terminal Expansion exceed the FERC limit of 55 dBA  $L_{dn}$ , Golden Pass would reduce the terminal’s noise contribution to result in a noise level that is no higher than the FERC guideline. We are also recommending that Golden Pass file a full-load noise survey no later than 60 days after placing all the Terminal Expansion facilities, including the MP 1 Compressor Station, in service. Therefore, we conclude that operational noise from the expanded terminal, and MP 1 Compressor Station, would result in minor impacts on the nearest NSAs.

Sound levels would increase during operation of the MP 33 Compressor Station and MP 66 Compressor Station and during maintenance activities. Those sound level increases would occur for the life of the Project. Golden Pass would implement mitigation measures to reduce noise impacts, such as installing the compressor units in an acoustically designed building. Based on our noise analysis, the predicted noise levels attributable to operation of the MP 33 Compressor Station and MP 66 Compressor

Station would be less than 55 dBA  $L_{dn}$  at all nearby NSAs. To ensure that noise levels would be below 55 dBA  $L_{dn}$ , we are recommending that Golden Pass file noise surveys during full-load operations and—if the noise levels exceed the FERC guideline, that Golden Pass install additional noise controls to meet the guideline within 1 year of the in-service date. As a result, we conclude that the impact on noise levels during operation would be minor.

### **Cumulative Impacts**

We considered the cumulative contributions of the proposed Project in specific impact areas for resources affected by the Project. As a part of that assessment, we identified existing projects, projects under construction, and reasonably foreseeable projects. These included existing LNG terminals and future LNG liquefaction projects, currently operating and future oil and gas projects, land transportation projects, commercial developments, dredging projects, and agriculture/silviculture. Our assessment considered the impacts of the proposed Project combined with the impacts of the other projects on resources within all or part of the same area and time. We conclude that the Project's contribution to impacts on resources affected by the Project would not result in significant cumulative impacts.

More detailed discussions of Project impacts, Golden Pass' proposed mitigation, and our recommendations to avoid or further reduce impacts are presented in sections 4.0 and 5.0 of this EIS.

### **ALTERNATIVES CONSIDERED**

We assessed the No-Action Alternative, system alternatives, and other siting and design alternatives that could achieve the Project objectives. The range of alternatives that could achieve the Project objectives included system alternatives, alternative Terminal Expansion sites, alternative Terminal Expansion configurations and designs, alternative Pipeline Expansion aboveground facility sites, and alternative compressor station designs. Alternatives were evaluated and compared to the Project to determine whether these alternatives were environmentally preferable to the proposed Project. While the No-Action Alternative would avoid the environmental impacts identified in this EIS, adoption of this alternative would preclude meeting the Project objectives. If the Project is not approved and built, the need could potentially be met by other LNG export projects developed elsewhere in the Gulf Coast region or in other areas of the United States. Implementation of other LNG export projects likely would result in impacts similar to or greater than those of the proposed Project.

We evaluated 23 Terminal Expansion system alternatives, including five existing LNG import terminals with planned, proposed, or authorized liquefaction projects; and 18 stand-alone LNG export terminals. To meet all or part of Golden Pass' contractual agreements, each of these projects would require substantial construction beyond what is currently planned and would not offer significant environmental advantages over the proposed Terminal Expansion. In addition, the permitting and authorization processes for constructing additional facilities and the time required for construction would substantially delay meeting the proposed timeline for the Terminal Expansion. As a result, we eliminated all potential system alternatives from further consideration.

We evaluated alternative sites for the Terminal Expansion within upland areas in a 4-mile radius of the existing terminal. Four miles is an accepted maximum length for efficient functioning of cryogenic LNG pipelines used to transport LNG from the liquefaction facilities to the LNG storage tanks. Four of the five sites identified as potential alternatives are comprised of substantial existing development or are close to existing development, including residences, schools, commercial and retail facilities, parks and roads. We concluded that these sites would be impractical, and they were eliminated from further consideration. The only upland site we identified within the 4-mile radius as a potentially viable alternative is about 0.3 mile southeast of the Terminal Expansion. Although this alternative site includes about 84 acres of upland area, the amount of available upland is not adequate to construct the liquefaction trains and associated

facilities. Thus, construction at this site would disturb about 436 acres of wetlands as compared to the 381 acres of wetlands that would be affected by construction at the proposed Terminal Expansion site. This site was therefore dismissed from consideration.

We also reviewed whether alternative configurations of the Terminal Expansion, Supply Dock, and liquefaction train power supply could substantially reduce potential environmental impacts and concluded that these alternatives would not be environmentally preferable.

The entire Pipeline Expansion route overlaps existing rights-of-way. As a result, many types of environmental impacts have been lessened compared to establishing new rights-of-way. We did not identify any site-specific environmental concerns that would drive the need to evaluate alternative pipeline routes, nor were any alternatives suggested during the public scoping period. We also assessed alternative sites and designs for each of the three compressor stations. We conclude that none of the alternative sites or designs considered for the compressor stations offers a significant environmental advantage over those of the proposed Project.

## CONCLUSIONS

We conclude that, if constructed and operated in accordance with applicable laws and regulations, Golden Pass' proposed mitigation, and our recommendations presented in section 5.2 of the EIS, the Project would result in some adverse environmental impact; however, those impacts would not be significant. The principal reasons for our conclusion include the following:

- The Terminal Expansion facilities would expand an existing, operating LNG import terminal with existing LNG storage tanks, berthing and loading/unloading facilities.
- Golden Pass' compensatory mitigation plans would adequately address impacts on wetlands.
- Adequate safety features would be incorporated into the design and operation of the Terminal Expansion facilities.
- The proposed pipeline route would be within or adjacent to existing rights-of-way.
- Golden Pass would implement the FERC's *Upland Erosion Control, Revegetation, and Maintenance Plan* and FERC's *Wetland and Waterbody Construction and Mitigation Procedures* to minimize construction impacts on soils, wetlands, and waterbodies.
- Use of the horizontal directional drilling method for pipeline installation under wetland habitat would avoid disturbances to those resources.
- The Project would not affect or would not be likely to adversely affect any federally or state-listed threatened or endangered species.
- The Project would not affect cultural resources.
- All appropriate consultations with the U.S. Fish and Wildlife Service, Louisiana Department of Wildlife and Fisheries, National Oceanic and Atmospheric Administration's National Marine Fisheries Service, and U.S. Department of Agriculture's Natural Resources Conservation Service would be completed before construction is allowed to start in any given area.
- The FERC's environmental and engineering inspection and mitigation monitoring program for this Project would ensure compliance with all mitigation measures and conditions of any FERC authorization.

In addition, we developed site-specific mitigation measures that Golden Pass should implement to further reduce the environmental impacts that would otherwise result from construction of the Project. We are recommending that these mitigation measures, presented in section 5.2 of the EIS, be attached as conditions to any authorization issued by the Commission for the Project.

## 1.0 INTRODUCTION

On July 7, 2014, Golden Pass Products LLC (GPP) filed an application with the Federal Energy Regulatory Commission (Commission or FERC) pursuant to Section 3 of the Natural Gas Act of 1938 (NGA) requesting authorization to site, construct, and operate liquefaction and export facilities adjacent to and integrated with its existing liquefied natural gas (LNG) terminal in Jefferson County, Texas. This action is referred to in this Environmental Impact Statement (EIS) as the Golden Pass Export Terminal Expansion (Terminal Expansion). It would allow GPP to liquefy domestic natural gas supplies for the export to global markets of about 15.6 million metric tons per year (mtpy) of LNG.

Also on July 7, 2014, Golden Pass Pipeline LLC (GPPL) filed an application with the FERC pursuant to Section 7(c) of the NGA requesting authorization to site, construct, operate, and maintain a new pipeline loop<sup>5</sup>, three new compressor stations, and modifications to existing pipeline interconnections in Jefferson and Orange Counties, Texas, and Calcasieu Parish, Louisiana. This action is referred to in this EIS as the Golden Pass Export Pipeline Expansion (Pipeline Expansion). It would add bi-directional flow capability to the existing Golden Pass Pipeline system. This would enable transport of natural gas from various interstate pipeline interconnections to the Terminal Expansion for liquefaction and export while retaining the ability to send out regasified (vaporized) imported LNG from the existing Golden Pass LNG Terminal (Golden Pass Import Terminal) to the same pipeline interconnections.

The combined GPP and GPPL actions and facilities are referred to herein as the Golden Pass LNG Export Project (Project), and the applicants are collectively referred to as Golden Pass. As part of the Commission's consideration of these applications, we<sup>6</sup> prepared this EIS to assess the potential environmental impacts resulting from construction and operation of the Project in accordance with the requirements of the National Environmental Policy Act of 1969 (NEPA).

The existing Golden Pass Import Terminal is on the west side of the Sabine Neches Waterway (SNWW), about 10 miles south of the City of Port Arthur, Texas, and 2 miles north of the community of Sabine Pass, Texas. The Golden Pass Import Terminal is authorized to receive LNG by marine vessel shipment (LNG carriers) for regasification and transport by pipeline to nine interconnections with interstate and intrastate pipelines that provide access to markets throughout the United States. The Terminal Expansion would allow the export of domestic natural gas in the form of LNG from the expanded terminal. Golden Pass is not requesting changes to the maximum number of annual LNG carrier transits to the existing berths or to the size of carriers that would transport the LNG.

In addition to liquefying natural gas and exporting LNG, the expanded terminal would continue to have the capability to regasify imported LNG. However, the design of the facility would not allow concurrent liquefaction, regasification, and transfer of LNG to and from LNG carriers. As a result, at any point in time, the expanded terminal would operate exclusively as a liquefaction and export facility or exclusively as an import and regasification facility. Golden Pass anticipates initiating export of LNG in 2020 and beginning full production (up to 15.6 mtpy) in 2021.

The Terminal Expansion would include the following facilities:

- feed gas pre-treatment facilities, including a mercury removal system, an amine system for removal of carbon dioxide (CO<sub>2</sub>) and hydrogen sulfide (H<sub>2</sub>S) followed by molecular sieve dehydration, and a heavy hydrocarbon (pentane and heavier [C<sub>5</sub>+]) removal system;

---

<sup>5</sup> A "loop" is a segment of pipeline that is usually installed adjacent to an existing pipeline and connected to it at both ends. The loop allows more gas to be moved through the system.

<sup>6</sup> "We," "us," and "our" refer to the environmental staff of the FERC's Office of Energy Projects.

- three liquefaction trains, each with a liquefaction capacity of 5.2 mtpy of LNG for export;
- liquefaction facility utilities and associated systems;
- a truck loading/unloading area;
- refrigerant make-up and condensate product storage tanks; and
- a supply dock (referred to as a marine offloading facility [MOF] in the Application to the FERC).

The Pipeline Expansion would provide bi-directional flow capability along the Golden Pass Pipeline system and would consist of the following facilities:

- about 2.6 miles of 24-inch-diameter pipeline loop between mileposts (MP) 63 and 66 of the existing Golden Pass Pipeline;
- three compressor stations (about 120,000 site-rated brake horsepower [hp] total) to facilitate the receipt and delivery of a maximum of 2.7 billion cubic feet per day (bcfd) of natural gas supply to the Terminal Expansion; and
- modifications to existing interconnections and metering facilities with the Natural Gas Pipeline Company of America (NGPL), Texoma Pipeline Company (Texoma), Tennessee Gas Pipeline (TGP), Texas Eastern Transmission Company, LP (TETCO), and Transcontinental Gas Pipe Line Company, LLC (Transco) systems.

The proposed pipeline would be installed parallel and adjacent to the existing Golden Pass Pipeline, from the existing interconnection with the TGP pipeline to the new compressor station at MP 66 (MP 66 Compressor Station) near the existing interconnection with the TETCO pipeline. Golden Pass anticipates construction of the Pipeline Expansion to begin in 2018 and be completed in 2019.

Under Section 3 of the NGA, the Commission considers all factors bearing on the public interest as part of its decision to authorize natural gas facilities. Specifically, regarding whether to authorize natural gas facilities used for importation or exportation, the Commission shall authorize the proposal unless it finds that the proposed facilities will not be consistent with the public interest.

Under Section 7 of the NGA, the Commission determines whether interstate natural gas transportation facilities are in the public convenience and necessity and, if so, grants a Certificate to construct and operate them. The Commission bases its decisions on technical competence, financing, rates, market demand, gas supply, environmental impact, long-term feasibility, and other issues concerning a proposed project.

## **1.1 PROJECT PURPOSE AND NEED**

Golden Pass states that the purpose of the Project would be to liquefy and export domestic natural gas to global markets. This would be accomplished by adding liquefaction facilities at the existing Golden Pass Import Terminal and modifying the existing Golden Pass Pipeline by constructing about 2.6 miles of new 24-inch-diameter pipeline and associated compressor stations and appurtenant facilities. Siting of the new facilities adjacent to existing facilities would minimize the footprint of the overall Project, and particularly of the Terminal Expansion.

The objectives of the Project are to:

- enable bi-directional flow of natural gas along the Golden Pass Pipeline system and thereby allow natural gas to be received from domestic sources;

- expand the existing Golden Pass Import Terminal to receive, treat, liquefy, and store domestic natural gas; and
- load LNG into vessels berthed at the existing marine facility to transport LNG to global markets.

Once the Terminal and Pipeline Expansions are completed and placed in service, Golden Pass would have the ability to receive and liquefy domestic natural gas and receive and regasify imported LNG. When global market demand is sufficient, Golden Pass would be able to export LNG; conversely, if domestic demand increased, Golden Pass could elect to receive cargoes of LNG and distribute it to markets within the United States.

Section 3 of NGA, as amended, requires that authorization be obtained from the Department of Energy (DOE) prior to importing or exporting natural gas, including LNG, from or to a foreign country. For applicants that have, or intend to have, a signed gas purchase or sales agreement/contract for a period of time longer than 2 years, long-term authorization is required. Under Section 3 of the NGA, the FERC considers, as part of its decision to authorize natural gas facilities, all factors bearing on the public interest. Specifically, regarding whether to authorize natural gas facilities for importation or exportation, the FERC shall authorize the proposal unless it finds that the proposed facilities will not be consistent with the public interest.

Under Section 7(c) of the NGA, the Commission determines whether interstate natural gas transportation facilities are in the public convenience and necessity and, if so, grants a Certificate to construct and operate them. The Commission bases its decisions on technical competence, financing, rates, market demand, gas supply, environmental impact, long-term feasibility, and other issues concerning a proposed project.

## **1.2 PURPOSE AND SCOPE OF THIS EIS**

The principal purposes in preparing an EIS are to:

- identify and assess potential impacts on the human environment that would result from implementation of the proposed action;
- identify and assess reasonable alternatives to the proposed action that would avoid or minimize adverse effects on the human environment;
- facilitate public involvement in identifying significant environmental impacts; and
- identify and recommend specific mitigation measures to avoid or minimize environmental impacts.

This EIS focuses on constructing and operating the facilities that are under the FERC's jurisdiction (i.e., the Terminal Expansion and Pipeline Expansion). The topics addressed include geology; soils; water use and quality; wetlands; vegetation; wildlife; fisheries and essential fish habitat (EFH); threatened, endangered, and special-status species; land use, recreation, and visual resources; socioeconomics; transportation; cultural resources; air quality; noise; reliability and safety; cumulative impacts; and alternatives. This EIS describes the affected environment as it currently exists and the potential environmental consequences of the Project, and compares the Project's potential impacts to those of alternatives. This EIS also presents our conclusions and recommended mitigation measures.

The Energy Policy Act of 2005 (EPA 2005) provides that the FERC shall act as the lead agency for coordinating all applicable authorizations related to jurisdictional natural gas facilities and for purposes of complying with NEPA. The FERC, as the "lead federal agency," is responsible for preparation of this



EIS. This effort was undertaken with the participation and assistance of the U.S. Army Corps of Engineers (COE); the U.S. Coast Guard (Coast Guard); the DOE, Office of Fossil Energy (DOE/FE); the U.S. Department of Transportation, Pipeline and Hazardous Materials Safety Administration (DOT); and the U.S. Environmental Protection Agency (EPA) as “cooperating agencies” under NEPA. Cooperating agencies have jurisdiction by law or special expertise with respect to environmental impacts involved with a proposal. The roles of the FERC, COE, Coast Guard, DOE, DOT, and EPA in the environmental review process are described below. The EIS provides a basis for coordinated federal decision making in a single document, thereby avoiding duplication among federal agencies in the NEPA environmental review processes. In addition to the lead and cooperating agencies, other federal, state, and local agencies may use this EIS in approving or issuing permits for all or part of the Project. Federal, state, and local permits, approvals, and consultations for the Project are provided in section 1.5.

### **1.2.1 Federal Energy Regulatory Commission**

Based on its authority under the NGA, the FERC is the lead agency for preparation of this EIS in compliance with the requirements of NEPA, the Council on Environmental Quality’s (CEQ) regulations for implementing NEPA (Title 40 of the Code of Federal Regulations, Parts 1500–1508 [40 CFR 1500–1508]), and FERC regulations implementing NEPA (18 CFR 380).

As the lead federal agency for the environmental review of the Project, the FERC is required to comply with Section 7 of the Endangered Species Act (ESA), as amended; the Magnuson-Stevens Fishery Conservation and Management Act (MSFCMA); Section 106 of the National Historic Preservation Act (NHPA); and Section 307 of the Coastal Zone Management Act (CZMA). Each of these statutes has been taken into account in the preparation of this EIS. The FERC will use this document to consider the environmental impacts that could result if it issues an authorization to Golden Pass under Section 3 of the NGA and a Certificate to Golden Pass under Section 7(c) of the NGA.

### **1.2.2 U.S. Army Corps of Engineers**

The COE has jurisdictional authority pursuant to Section 404 of the Clean Water Act (CWA) (Title 33 of the United States Code [USC], Section 1344 [33 USC 1344]), which governs the discharge of dredged or fill material into waters of the United States, and Section 10 of the Rivers and Harbors Act (33 USC 403), which regulates any work or structures that potentially affect the navigable capacity of a waterbody. The COE would adopt the EIS in compliance with 40 CFR 1506.3 if, after an independent review of the document, it concludes that the EIS satisfies COE’s comments and suggestions. The Project is within the Galveston District of the COE Southwestern Division and the New Orleans District of the COE Mississippi Valley Division. Staff from these districts participated in the NEPA review and will evaluate COE authorizations, as applicable.

The primary decisions to be addressed by the COE include:

- issuance of Section 404 Permits for dredging activities and wetland impacts associated with construction of the Terminal Expansion and the Pipeline Expansion;
- issuance of a Section 10 Permit for construction activities within navigable waters of the United States; and
- issuance of a Nationwide Permit 12 for construction activities associated with the Pipeline Expansion.

This EIS contains information needed by the COE to reach decisions on these issues. Through the coordination of this document, the COE will obtain the views of the public and natural resource agencies prior to reaching its decisions on the Project.

The COE must review and consider whether a proposed project avoids, minimizes, and compensates for impacts on existing aquatic resources, including wetlands, to achieve a goal of no overall net loss of values and functions. The COE must also evaluate whether or not a project has “water dependency.” The COE would issue a Record of Decision to formally document its decisions on the proposed action, including Section 404(b)(1) analyses and required environmental mitigation commitments.

### **1.2.3 U.S. Coast Guard**

The Coast Guard is the federal agency responsible for determining the suitability of waterways for LNG marine traffic. The Coast Guard exercises regulatory authority over LNG facilities that affect the safety and security of port areas and navigable waterways under Executive Order 10173; the Magnuson Act (50 USC 191); the Ports and Waterways Safety Act of 1972, as amended (33 USC 1221 et seq.); and the Maritime Transportation Security Act of 2002 (MTSA) (46 USC 701). The Coast Guard is responsible for matters related to navigation safety, vessel engineering and safety standards, and all matters pertaining to the safety of facilities or equipment in or adjacent to navigable waters up to the last valve immediately before the receiving tanks. The Coast Guard also has authority for LNG facility security plan reviews, approval and compliance verification as provided in 33 CFR 105, and siting as it pertains to the management of vessel traffic in and around LNG facilities to a point 12 nautical miles seaward from the coastline (i.e., within the territorial seas).

As required by its regulations, the Coast Guard is responsible for issuing a Letter of Recommendation (LOR) as to the suitability of the waterway for LNG marine traffic, following a Waterway Suitability Assessment (WSA). In a letter dated May 13, 2013, the Coast Guard stated it would not require revisions to the current WSA for the Project nor would another LOR be required because no additional LNG carrier traffic or routes are requested for the Terminal Expansion. However, the Coast Guard would require Golden Pass to provide applicable amendments to its *Operations Manual*, *Emergency Manual*, and *Facility Security Plan* for the Terminal Expansion.

### **1.2.4 U.S. Department of Energy**

The DOE must meet its obligation under Section 3 of the NGA to authorize the import and export of natural gas, including LNG, unless it finds that the import or export is not consistent with the public interest. Golden Pass filed applications with the DOE/FE (Docket Nos. 12-88-LNG and 12-156-LNG) on August 17, 2012, and October 26, 2012, seeking authorization to export up to 15.6 mtpy of domestically produced LNG for a 25-year period, commencing the earlier of either the date of first export or 7 years from the date of issuance of the requested authorization. Golden Pass seeks to export LNG from the expanded LNG Terminal to any country (1) with which the United States has, or in the future may have, a free trade agreement requiring national treatment for trade in natural gas; (2) with which the United States does not have a free trade agreement requiring the national treatment for trade in natural gas and LNG; (3) that has, or in the future develops, the capacity to import LNG; and (4) with which trade is not prohibited by United States law or policy.

On September 27, 2012, the DOE/FE issued an order granting authorization to Golden Pass to export LNG by vessel from the Golden Pass Import Terminal to any country which has, or in the future develops, the capacity to import LNG via ocean-going carrier and with which the United States has, or in the future enters into, a free trade agreement requiring national treatment for trade in natural gas. Section 3(c) of the NGA, as amended by Section 201 of the Energy Policy Act of 1992 (Public Law 102-486), requires that applications to authorize the import and export of natural gas, including LNG, from and to a nation with which there is in effect a free trade agreement requiring national treatment for trade in natural gas be deemed consistent with the public interest and granted without modification or delay. The DOE/FE has not yet granted Golden Pass export authority to countries without a free trade agreement. In

accordance with 40 CFR 1506.3, after an independent review of the EIS, the DOE/FE may adopt the document prior to issuing a Record of Decision on the Golden Pass application for authority to export LNG to countries without a free trade agreement.

### **1.2.5 U.S. Department of Transportation**

The DOT has prescribed the minimum federal safety standards for LNG facilities in compliance with 49 USC 60101. Those standards are codified in 49 CFR 193 and apply to the siting, design, construction, operation, maintenance, and security of LNG facilities. The National Fire Protection Association (NFPA) Standard 59A, “Standard for the Production, Storage, and Handling of Liquefied Natural Gas,” is incorporated into these requirements by reference, with regulatory preemption in the event of conflict. In accordance with the 1985 Memorandum of Understanding on LNG facilities and the 2004 Interagency Agreement on the safety and security review of waterfront import/export LNG facilities, the DOT participates as a cooperating agency. The DOT does not issue a permit or license, but as a cooperating agency, assists the FERC staff in evaluating whether an applicant’s proposed design would meet the DOT requirements. On June 11, 2015, the DOT approved Golden Pass’ methodologies for single accidental leakage sources and wind speed for the design of the facility. Informal consultation between Golden Pass and the DOT regarding additional LNG and pipeline safety and federal safety standards is currently ongoing.

### **1.2.6 U.S. Environmental Protection Agency**

The EPA has delegated water quality certification (Section 401 of the CWA) to the jurisdiction of individual state agencies, but the EPA may assume this authority if no state program exists, if the state program is not functioning adequately, or at the request of a state. Water used for hydrostatic testing of pipelines that is point-source discharged into waterbodies requires a National Pollutant Discharge Elimination System (NPDES) Permit (Section 402 of the CWA) issued by the state with EPA oversight. For the Project, this authority is assumed by Texas and Louisiana with EPA oversight. In addition, the EPA has the authority to review and veto COE decisions on Section 404 Permits.

The EPA also has jurisdictional authority to control air pollution under the Clean Air Act (CAA) (42 USC 85) by developing and enforcing rules and regulations for all entities that emit toxic substances into the air. Under this authority, the EPA has developed regulations for major sources of air pollution. The EPA has delegated the authority to implement these regulations to state and local agencies, while state and local agencies are allowed to develop their own regulations for non-major sources. The EPA also establishes general conformity applicability thresholds; a federal agency can use these thresholds to determine whether a specific action requires a general conformity assessment. In addition to its permitting responsibilities, the EPA is responsible for implementing certain procedural provisions of NEPA (e.g., publishing the Notices of Availability of the draft and final EISs in the Federal Register) to establish statutory timeframes for the environmental review process.

## **1.3 PUBLIC REVIEW AND COMMENT**

### **1.3.1 Notices and Meetings**

On May 16, 2013, Golden Pass filed a request with the FERC to use our pre-filing review process. At that time, Golden Pass was in the preliminary design stage of the Project and no formal applications had been filed with the FERC. This request was approved on May 30, 2013. Pre-filing Docket No. PF13-14-000 was established for the Project to place information filed by Golden Pass and related documents issued by the FERC into the public record. The pre-filing review process provides opportunities for interested stakeholders to become involved early in project planning, facilitates interagency cooperation, and assists in the identification and resolution of issues prior to a formal application being filed with the FERC.

Golden Pass held public open houses in Starks, Louisiana, on July 29, 2013; Sabine Pass, Texas, on July 30, 2013; and Vidor, Texas, on August 1, 2013. The FERC staff participated in those meetings to describe the FERC process and provide those attending with information on how to file comments with the FERC. In July 2013 and June 2014, FERC staff visited the existing Golden Pass Import Terminal, the proposed Terminal Expansion site, the proposed pipeline route, and the proposed sites of the new compressor stations.

On August 1, 2013, and June 11, 2014, joint interagency meetings for the Project were conducted with representatives of the FERC, COE, U.S. Fish and Wildlife Service (FWS), National Oceanic and Atmospheric Administration's (NOAA) National Marine Fisheries Service (NOAA Fisheries), Texas Parks and Wildlife Department (TPWD), and Golden Pass representatives to discuss impacts on wetlands, EFH, migratory birds, and threatened and endangered species; coordination of agency reviews; permit requirements and permit application status; and each agency's interest in participating in our environmental review as a cooperating agency. In addition, interagency conference calls were conducted bi-weekly with Golden Pass representatives throughout the pre-filing period.

On September 9, 2013, the FERC issued a *Notice of Intent to Prepare an Environmental Assessment<sup>7</sup> for the Planned Golden Pass LNG Export Project and Golden Pass Export Pipeline Project, Request for Comments on Environmental Issues, and Notice of Public Scoping Meeting* (NOI). This notice was sent to about 560 interested parties, including federal, state, and local officials; agency representatives; conservation organizations; federally recognized Indian tribes; local libraries and newspapers in the Project area; and property owners in the vicinity of planned Project facilities. Publication of the NOI established a 30-day public comment period for submission of comments, concerns, and issues related to the environmental aspects of the Project.

### **1.3.2 Scoping Comments**

On October 2 and 3, 2013, we conducted public scoping meetings in Starks, Louisiana, and Sabine Pass, Texas, respectively, to provide an opportunity for the public to learn more about the Project and provide comments on environmental issues to be addressed in the EIS. One person expressed support for the Project at the Starks scoping meeting, primarily regarding Golden Pass' current operations and the expected increase in jobs. A total of three people commented at the Sabine Pass scoping meeting. All three commenters expressed support for the Project, in particular the future economic benefit to the area; however, concern was expressed for potential noise and light pollution issues and effective utilization of recovered power. One additional scoping comment was received requesting Golden Pass sponsorship of the local schools.

During the scoping period, we received nine comment letters from citizens and interested parties such as local Chambers of Commerce, Port Authorities, and business associations; seven comment letters from members of the U.S. Congress and the Texas Congress; one comment letter from a public interest group; and comment letters from the EPA, FWS, Texas General Land Office (TGLO), and TPWD.<sup>8</sup> Issues identified during the scoping period that are within the scope of the environmental analysis are summarized in table 1.3-1, along with a listing of the EIS sections that address the comments.

An additional issue was raised during scoping: the extent to which the Project would stimulate natural gas drilling activity and the potential subsequent environmental effects associated with such an

---

<sup>7</sup> Subsequently changed to an EIS by the FERC.

<sup>8</sup> Transcripts of the public scoping meetings and comments received during the scoping period are part of the public record for the Project (Docket No. PF13-14-000, Accession Nos. 20131018-4006 and 20131018-4005), and are available on the FERC website at <http://ferc.gov/docs-filing/elibrary.asp>.

expansion. Because this issue is outside the scope of the environmental analysis, it is not addressed further in the EIS.

<b>TABLE 1.3-1</b>	
<b>Issues Identified and Comments Received during the Public Scoping Period for the Golden Pass LNG Export Project</b>	
<b>Issue/Specific Comment</b>	<b>EIS Section Addressing Comment</b>
<b>General</b>	
Purpose and Need	1.1
<b>Alternatives</b>	
Alternatives analysis criteria	3.0
Range of alternatives considered	3.0
<b>Water Resources</b>	
Impacts on water quality from dredging, in-water construction, and ship transits	4.3
Drainage pattern and floodplain identification	4.3.1
Impacts on surface water quality from discharges and stormwater pollution	4.3.2
Impacts on aquatic environment from contaminated sediments	4.3.2
Navigable waterway permitting	4.3.2
<b>Wetlands</b>	
Wetland construction and mitigation procedures	4.4
<b>Vegetation</b>	
Impacts on critically imperiled vegetation species	4.5.1
Construction and maintenance impacts on vegetation and restoration techniques	4.5.1
Efforts to minimize the introduction of invasive species	4.5.2
<b>Fish and Wildlife Resources</b>	
Migratory bird conservation efforts	4.6.2
Impacts on Essential Fish Habitat	4.6.4
<b>Threatened, Endangered, and Other Special-Status Species</b>	
Impacts on threatened and endangered species and suitable habitat	4.7
Jeopardy to endangered species and destruction of critical habitat	4.7
<b>Socioeconomics</b>	
Impact on minority and low-income populations	4.9
Impact on communities in the vicinity	4.9
<b>Cultural Resources</b>	
NHPA Section 106 consultation and analysis	4.10
Consultation with tribal governments	4.10.3
Impacts on tribal, cultural, or other treaty resources and mitigation efforts	4.10.3
<b>Air Quality and Noise</b>	
Emissions from the Terminal Expansion and marine vessels and mitigation measures	4.11.1
Global greenhouse gas emissions	4.11.1
Impacts on local and global air quality and noise from construction and operation of the Terminal Expansion and Pipeline Expansion	4.11.2

<b>TABLE 1.3-1 (continued)</b>	
<b>Issues Identified and Comments Received during the Public Scoping Period for the Golden Pass LNG Export Project</b>	
<b>Issue/Specific Comment</b>	<b>EIS Section Addressing Comment</b>
<b>Hazardous Materials and Waste</b>	
Impacts of hazardous waste from construction and operation	4.2
Hazardous Waste Management Plan	2.0
Hazardous waste mitigation and alternatives	2.0
<b>Safety</b>	
Risk of catastrophic and explosive releases of LNG, natural gas, or other hazardous substances	4.12
<b>Cumulative Impacts</b>	
Cumulative impacts of existing, proposed, and reasonably foreseeable future projects	4.13
Global greenhouse gas emissions	4.13.2

**1.4 NON-JURISDICTIONAL FACILITIES**

Under Section 7 of the NGA, the FERC is required to consider, as part of a decision to authorize jurisdictional facilities, all facilities that are directly related to a proposed project where there is sufficient federal control and responsibility to warrant environmental analysis as part of the NEPA environmental review for the proposed project. Some proposed projects have associated facilities that do not come under the jurisdiction of the Commission. These “non-jurisdictional” facilities may be integral to the need for the proposed facilities, or they may be merely associated as minor components of the jurisdictional facilities that would be constructed and operated as a result of authorization of the proposed facilities.

Two non-jurisdictional actions were identified in association with the Project: a tie-in with the City of Port Arthur water supply, and tanker truck transport of condensate from the Terminal Expansion. These actions are addressed below and are also addressed in the cumulative impacts analysis in section 4.13.

**1.4.1 City of Port Arthur Water Supply Tie-in**

Golden Pass would tie-in to the City of Port Arthur water supply line to provide fresh water to the Terminal Expansion. The tie-in would be collocated with the existing tie-in for the existing terminal. Golden Pass would remain responsible for the water line downstream of the tie-in; upstream of the terminal tie-in, the water line would be regulated by the City of Port Arthur and the Texas Commission on Environmental Quality (TCEQ).

**1.4.2 Truck Transport of Condensate**

Golden Pass would produce and store stabilized condensate as a by-product of the liquefaction process. Golden Pass would subsequently load the condensate into tanker trucks for delivery into the market place. Construction and operation of the truck loading facility within the Terminal Expansion is jurisdictional. However, the loaded tanker trucks would be non-jurisdictional once they leave the Terminal Expansion site. Tanker trucks carrying the condensate from the Terminal Expansion would use the paved public road routes in the vicinity of the terminal, including Texas State Highway (SH)-87, SH-82, and SH-73, likely connecting to Interstate 10. The DOT would require that condensate tanker trucks comply with

requirements for transporting hazardous materials. Tanker truck traffic likely would be less than five trucks per day, and we conclude that it would not significantly affect roadway traffic.

## 1.5 PERMITS, APPROVALS, AND REGULATORY REVIEWS

Federal agencies are required to comply with regulatory statutes including, but not limited to, NEPA, Section 7 of the ESA, the MSFCMA, the CAA, the CWA, the Rivers and Harbors Act, Section 106 of the NHPA, and Section 307 of the CZMA. Each of these statutes has been taken into account in the preparation of this EIS, as discussed in more detail below. The major permits, approvals, and consultations for the Project are identified in table 1.5-1.

Agency	Permit/Approval/ Consultation	Status	
		Terminal Expansion	Pipeline Expansion
<b>Federal</b>			
Federal Aviation Administration	Notification of Proposed Construction or Alteration	Anticipated notification first or second quarter of 2017	Not applicable
FERC	Authorization under Section 3 of the NGA	Application filed July 7, 2014	Not applicable
	Certification under Section 7 of the NGA	Not applicable	Application filed July 7, 2014
NOAA Fisheries	Section 7 of ESA consultation	Consultation ongoing	Not applicable
	Marine Mammal Protection Act consultation	Consultation ongoing	Not applicable
	Fish and Wildlife Coordination Act consultation	Consultation ongoing	Not applicable
	MSFCMA	Consultation ongoing	Not applicable
COE, Galveston, TX District	CWA Section 404 Permit	Application filed July 7, 2014	Application filed July 7, 2014
	Rivers and Harbors Act Section 10 Permit	Application filed July 7, 2014	Not applicable
COE, New Orleans, LA District	CWA Section 404 Nationwide 12 Permit	Not applicable	Anticipated application submittal in second quarter of 2017
Coast Guard	33 CFR 127; 2004 Interagency Agreement (NVIC 05-08) LOR	Letter received from Coast Guard on May 13, 2013, stating that existing LOR is still applicable	Not applicable
	Section 422 of The American Practical Navigator Local Notice to Mariners	Occurs prior to initiation of dredging or construction activities that will affect marine navigation	Not applicable

**TABLE 1.5-1 (continued)**

**Major Permits, Approvals, and Consultations for the  
Golden Pass LNG Export Project**

Agency	Permit/Approval/ Consultation	Status	
		Terminal Expansion	Pipeline Expansion
DOE	Authorization to Export Liquefied Natural Gas to Free Trade Agreement Countries	Authorization granted September 27, 2012 (DOE/FE Order No. 3147)	Not applicable
	Authorization to Export Liquefied Natural Gas by vessel to Non-Free Trade Agreement Countries	Application submitted October 2012 and is currently under review	Not applicable
EPA	CWA Section 402 Industrial Stormwater Permit	Anticipated submittal in 2018	Anticipated submittal in 2018
	CWA Section 402 Process Wastewater Permit	Anticipated submittal in 2018	Not applicable
	CWA Section 402 Construction General Permit Notification	Anticipated electronic notice submittal in 2016	Anticipated electronic notice submittal in 2016
FWS	Section 7 of ESA Consultation	Informal consultation ongoing	Informal consultation ongoing
	Migratory Bird Treaty Act Consultation	Informal consultation ongoing	Informal consultation ongoing
	Fish and Wildlife Coordination Act Consultation	Informal consultation ongoing	Informal consultation ongoing
DOT	49 CFR 192 Consultation (standards for natural gas pipelines)	Not applicable	Informal consultation ongoing
	49 CFR 193 Consultation (Standards for LNG facilities)	Informal consultation ongoing	Not applicable
<b>State – Texas</b>			
TCEQ, Air Quality Division	New Source Review (NSR) Pre-construction Air Permit for Construction Emissions PSD Standard Permit	PSD permit issued January 16, 2015, for Terminal Expansion	PSD permit issued January 16, 2015, for MP 1 Compressor Station
	Prevention of Significant Deterioration (PSD Permit) for Greenhouse Gas emissions	PSD Permit issued September 11, 2015	PSD Permit issued September 11, 2015
	Operation emissions (Title V) for Stationary Sources Permit	Anticipated application submittal in 2018	Anticipated application submittal in 2018
TCEQ, Water Quality Division	Texas Water Code Section 11.138 Temporary Water Use Appropriations Permit	Anticipated application submittal in 2016	Not applicable
TPWD	Threatened and Endangered Species Consultation	Consultation ongoing	Consultation ongoing
	Surface Use Agreement to conduct marsh restoration activities	Anticipated application submittal in third quarter of 2016	Not applicable
Texas Historical Commission State Historic Preservation Office	NHPA Section 106 Consultation	Consultation concurrence received August 2013 for Terminal Facilities; received April 2014 for Supply Dock	Consultation concurrence received March 2014 for Orange County compressor station



<b>TABLE 1.5-1 (continued)</b>			
<b>Major Permits, Approvals, and Consultations for the Golden Pass LNG Export Project</b>			
<b>Agency</b>	<b>Permit/Approval/ Consultation</b>	<b>Status</b>	
		<b>Terminal Expansion</b>	<b>Pipeline Expansion</b>
Railroad Commission of Texas	Hydrostatic Test Water Discharge Permit	Anticipated application submittal in 2017	Anticipated application submittal in 2016
	Texas Natural Resource Code Section 91.101 and Texas Water Code Section 26.131 Water Quality Certification	Application submitted July 7, 2014; revised January 13, 2016	Application submitted July 7, 2014; revised January 13, 2016
Railroad Commission of Texas and Texas General Land Office	CZMA Section 307 Application for Determination of Consistency with the Texas Coastal Management Program	Application submitted January 13, 2016	Application submitted January 13, 2016
<b>State – Louisiana</b>			
Louisiana Department of Environmental Quality (LDEQ), Air Quality Division	Title V and PSD Permits	Not applicable	Anticipated application submittal in 2017
LDEQ, Water Quality Division	Section 401 Water Quality Certification and Stormwater General Permit; Hydrostatic Test Water Discharge Permit	Not applicable	Anticipated application submittal in 2017
Louisiana Department of Wildlife and Fisheries	ESA consultation	Not applicable	Consultation ongoing
Louisiana Department of Culture, Recreation, and Tourism, Division of Archaeology	NHPA Section 106 consultation	Not applicable	Consultation concurrence received December 2013 for pipeline facilities; received March 2014 for Calcasieu Parish compressor stations
Louisiana Office of State Fire Marshall	RS 23:531-545 Boiler Inspection	Not applicable	Inspection anticipated to take place in 2016
<b>Local – Parish</b>			
Calcasieu Parish Police Jury	Building Permit	Not applicable	Anticipated application submittal in 2016

Section 7 of the ESA states that any project authorized, funded, or conducted by any federal agency should not "...jeopardize the continued existence of any endangered species or threatened species or result in the destruction or adverse modification of habitat of such species which is determined...to be critical..." (16 USC 1536[a][2][1988]). The FERC is required to determine whether any species are federally listed or proposed for listing as endangered or threatened, or their designated critical habitats occur in the vicinity of a project and conduct consultations with the FWS and/or NOAA Fisheries, if necessary. If, upon review of existing data or data provided by an applicant, the FERC determines that these species or habitats may be affected by a project, the FERC is required to prepare a Biological Assessment (BA) to identify the nature and extent of adverse impact, and to recommend measures that would avoid the habitat and/or

species, or would reduce potential impact to acceptable levels. Section 4.7 provides information on the status of this review for the Project.

The MSFCMA, as amended by the Sustainable Fisheries Act of 1996 (Public Law 104-267), established procedures designed to identify, conserve, and enhance EFH for those species regulated under a federal fisheries management plan. The MSFCMA requires federal agencies to consult with NOAA Fisheries on all actions or proposed actions authorized, funded, or undertaken by the agency that may adversely affect EFH (MSFCMA 305[b][2]). Although absolute criteria have not been established for conducting EFH consultations, NOAA Fisheries recommends consolidating EFH consultations with interagency coordination procedures required by other statutes, such as NEPA, the Fish and Wildlife Coordination Act, or the ESA (50 CFR 600.920[e]), to reduce duplication and improve efficiency. As part of this consultation process, the FERC prepared an EFH assessment, which is provided in section 4.6.3.

Section 106 of the NHPA requires that the FERC take into account the effects of its undertakings on properties listed, or eligible for listing, in the National Register of Historic Places (NRHP) – including prehistoric or historic sites, districts, buildings, structures, objects, or properties of traditional religious or cultural importance, and to afford the Advisory Council on Historic Preservation (ACHP) an opportunity to comment on the undertaking. Golden Pass, as a non-federal party, is assisting the FERC in meeting its obligations under Section 106 by preparing the necessary information, analyses, and recommendations under the ACHP regulations in 36 CFR 800. Section 4.10 provides information on the status of this review.

Golden Pass must comply with Sections 401 and 404 of the CWA. Water quality certification (Section 401) has been delegated to the state agencies, with review by the EPA. Water used for hydrostatic testing that is point-source discharged into waterbodies would require a NPDES Permit (Section 402). The COE has responsibility for determining compliance with all regulatory requirements associated with Section 404 of the CWA. The EPA also independently reviews Section 404 applications for wetland dredge-and-fill applications for the COE and has Section 404(c) veto power for wetland permits issued by the COE. The Section 404 permitting process regulates the discharge of dredged and fill material associated with construction of facilities across waterbodies and within wetlands. Before an individual Section 404 Permit can be issued, the CWA requires completion of a Section 404(b)(1) guideline analysis. The FERC, in the NEPA review represented by this EIS, has analyzed all technical issues required for the Section 404(b)(1) guideline analyses, including analysis of natural resources and cultural resources that would be affected by the Project, as well as analyses of alternatives. The results of our analysis of alternatives are provided in section 3.0, and a summary of wetland impacts is provided in section 4.4. In addition to CWA responsibilities, the COE has jurisdiction over Section 10 Permits, which would be required for all construction activities in navigable waterways under the Rivers and Harbors Act of 1899. Wetlands crossing methods and impacts on wetlands affected by the Project are summarized in section 4.3.

The EPAct 2005 and Section 3 of the NGA require us to consult with the U.S. Department of Defense (DOD) to determine whether there would be any impacts associated with the Project on military training or activities on any military installations. The FERC initiated consultation with a letter to the DOD on September 11, 2014. In a December 11, 2014 letter, DOD indicated through an informal review that the Project will have minimal impact on military training and operations conducted in the Project area.

The CZMA calls for the “effective management, beneficial use, protection, and development” of the nation’s coastal zone and promotes active state involvement in achieving those goals. As a means to reach those goals, the CZMA requires participating states to develop management programs that demonstrate how those states will meet their obligations and responsibilities in managing their coastal areas. In Texas, the TGLO accordingly administers the Texas Coastal Management Program (CMP). Golden Pass submitted a revised application for water quality certification and an application for determination of consistency with the Texas CMP on January 13, 2016. Project-related issues associated with the CZMP are addressed in section 4.8.6.

The CAA was enacted by Congress to protect the health and welfare of the public from the adverse effects of air pollution. The CAA is the basic federal statute governing air pollution. Federal and state air quality regulations established as a result of the CAA include Title V operating permit requirements and Prevention of Significant Deterioration (PSD) Review. The EPA is the federal agency responsible for regulating stationary sources of air pollutant emissions. The federal permitting process has been delegated to the TCEQ in Texas and the Louisiana Department of Environmental Quality (LDEQ) in Louisiana. Golden Pass received PSD permits from the TCEQ in January and September of 2015 and anticipates submitting applications for Title V permits to the TCEQ in 2018 and the LDEQ in 2017. Golden Pass anticipates submitting an application for a PSD permit from LDEQ in 2017. Air quality impacts that could occur as a result of construction and operation of the Project are addressed in section 4.11.1.

Golden Pass is responsible for obtaining all permits and approvals required to implement the Project regardless of whether they appear in table 1.5-1. However, any state or local permits issued with respect to jurisdictional facilities must be consistent with the conditions of any authorization the Commission may issue. Although the FERC encourages cooperation between applicants and state and local authorities, this does not mean that state and local agencies, through application of state and local laws, may prohibit or unreasonably delay the construction or operation of facilities approved by the FERC.<sup>9</sup>

---

<sup>9</sup> See, e.g., *Schneidewind v. ANR Pipeline Co.*, 485 U.S. 293 (1988); *National Fuel Gas Supply v. Public Service Commission*, 894 F.2d 571 (2d Cir. 1990); and *Iroquois Gas Transmission System, L.P., et al.*, 52 FERC 61,091 (1990) and 59 FERC ¶ 61,094 (1992).

## 2.0 PROPOSED ACTION

The Project consists of two main components: (1) the Terminal Expansion, involving expansion of the existing Golden Pass Import Terminal in Jefferson County, Texas; and (2) the Pipeline Expansion, involving expansion of the existing Golden Pass Pipeline through construction of about 2.6 miles of new 24-inch-diameter natural gas pipeline loop and appurtenant facilities in Jefferson and Orange Counties, Texas, and Calcasieu Parish, Louisiana. Figure 2.0-1 depicts the general location of the Project. Figure 2.0-2 depicts the locations of the key components of the Terminal Expansion. Figures 2.0-3 and 2.0-4, and appendix B depict the locations of the Pipeline Expansion facilities.

### 2.1 EXISTING FACILITIES

#### 2.1.1 Golden Pass Import Terminal

The Golden Pass Import Terminal encompasses about 300 acres on the Port Arthur Ship Canal along the SNWW in Jefferson County, Texas – about 10 miles south of Port Arthur, Texas, and 2 miles north of Sabine Pass, Texas. Golden Pass constructed the existing terminal to import LNG and to regasify and transport natural gas to the United States from foreign markets. In 2005, the terminal was authorized<sup>10</sup> by the Commission to send out 2.0 bcf/d of natural gas, with a peak capacity of 2.7 bcf/d. The environmental review for the existing terminal was provided in the FERC final EIS issued in June 2005.<sup>11</sup>

The existing terminal was placed into service in two phases, in March 2011 and May 2011. Golden Pass is currently authorized to receive a maximum of 200 LNG carriers per year at the terminal. Both the frequency and number of LNG carriers can vary depending on the size of carriers calling on the terminal; vessel cargo capacities range from 125,000 to 266,000 cubic meters (m<sup>3</sup>). LNG carriers destined for the existing terminal coordinate marine transportation efforts with the Coast Guard and Sabine Pilots.

The existing Golden Pass Import Terminal includes the following major facilities:

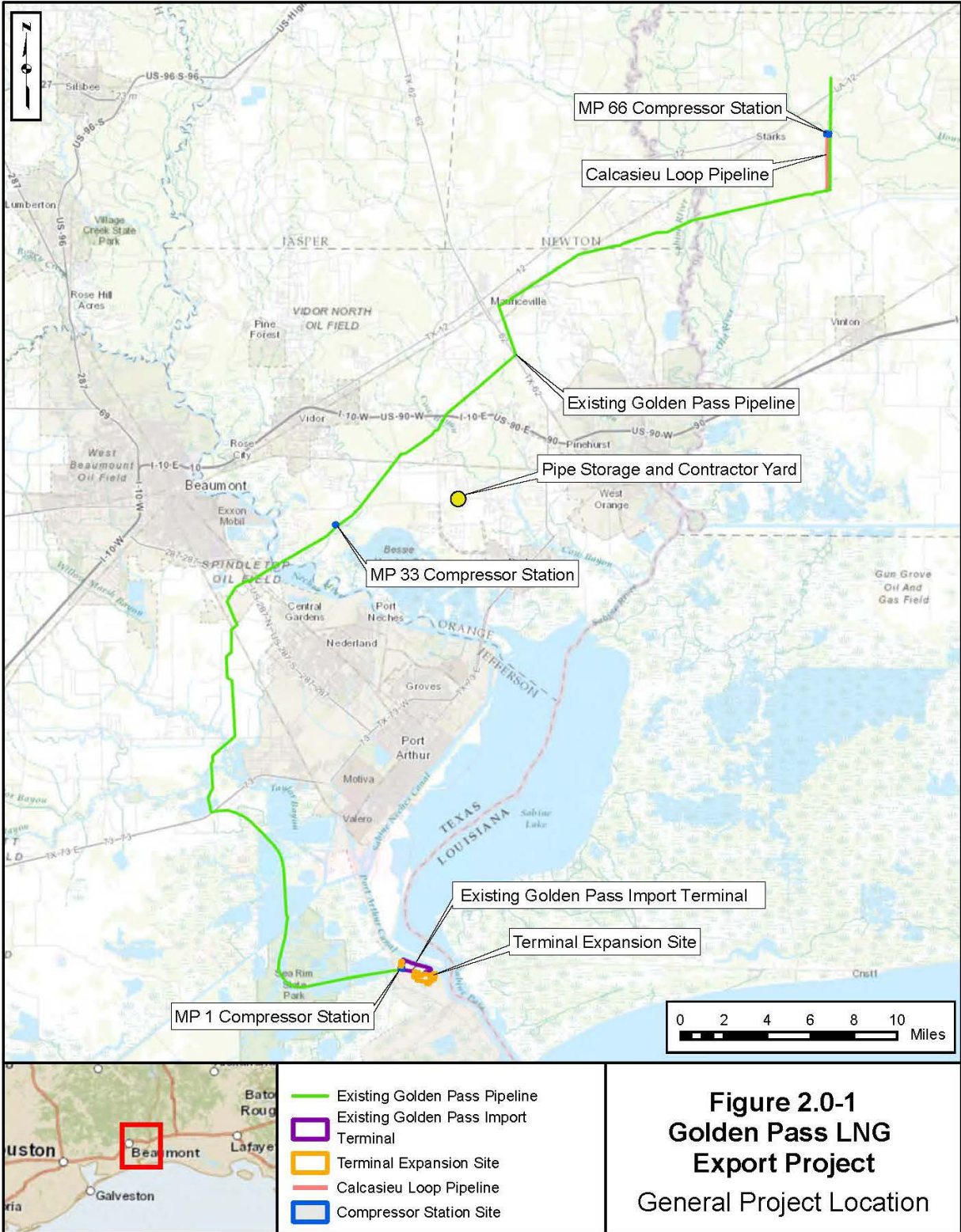
- one marine terminal or Ship Slip with berthing capabilities to moor two LNG carriers with cargo capacities between 125,000 and 266,000 m<sup>3</sup>;
- LNG unloading and transfer facilities with related mechanical and piping support systems;
- five full-containment LNG storage tanks,<sup>12</sup> each with an approximate capacity of 155,000 m<sup>3</sup>;
- ten LNG vaporizers and related gasification support systems capable of an annual sendout capacity of 2.0 bcf/d of natural gas and a peak capacity of 2.7 bcf/d; and
- ancillary buildings, facilities, and service utilities.

---

<sup>10</sup> Authorized on July 6, 2005 (FERC Docket No. CP04-386-000).

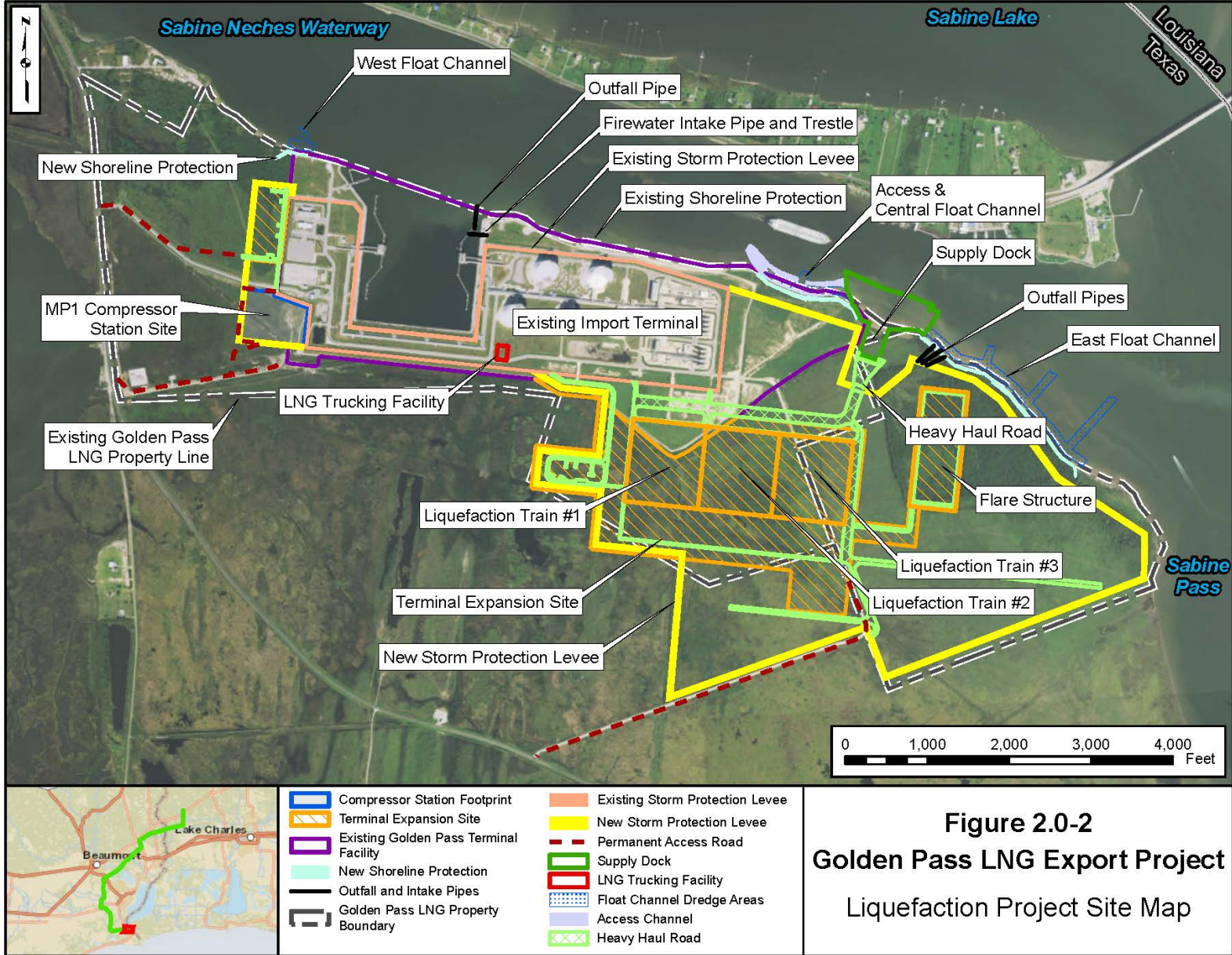
<sup>11</sup> Docket Nos. CP04-386, -400, -401, and -402; Accession No. 20050603-4000.

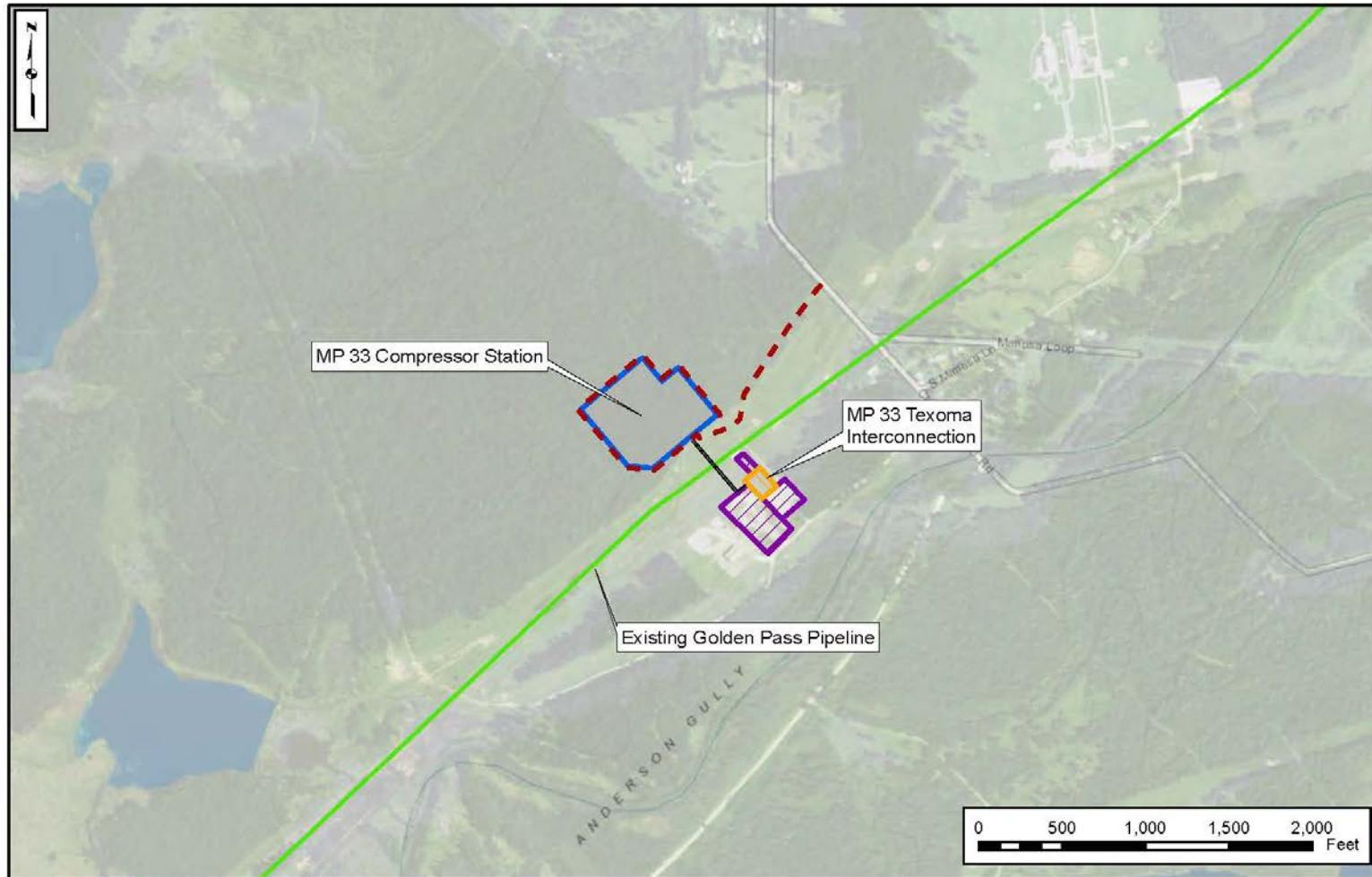
<sup>12</sup> Each storage tank consists of an inner steel tank and internal containment barrier surrounded by a secondary outer concrete tank, which is sized to contain 110 percent of the volume of the inner tank. A more detailed description is provided in section 2.2.1.2.



**Figure 2.0-1**  
**Golden Pass LNG**  
**Export Project**  
 General Project Location



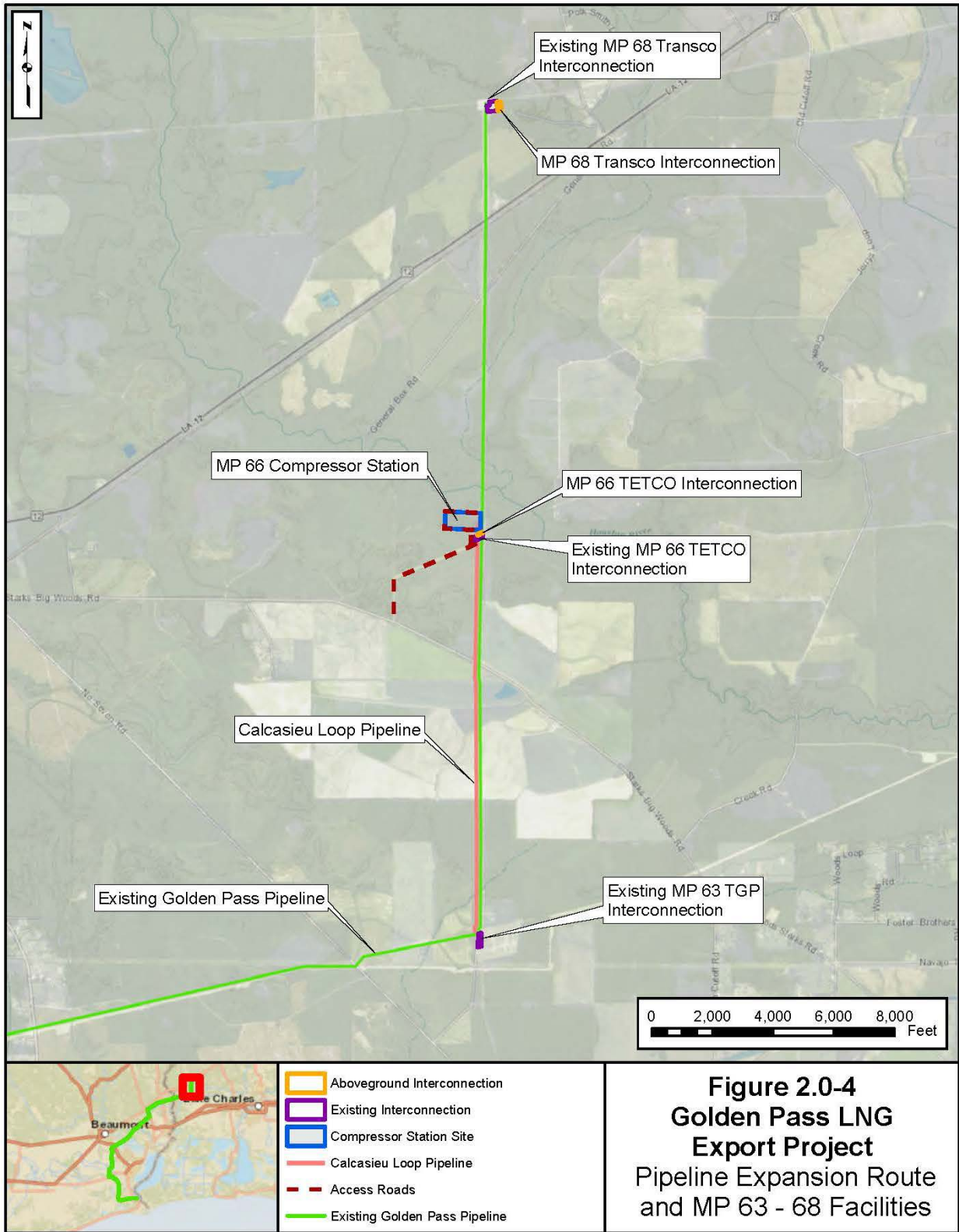




- Compressor Station Site
- Permanent Aboveground Interconnection
- Existing Interconnection
- Access Roads
- Existing Golden Pass Pipeline
- New Pipeline

**Figure 2.0-3**  
**Golden Pass LNG Export Project**  
Pipeline Expansion Route  
and MP 33 Facilities







## **2.1.2 Golden Pass Pipeline**

Golden Pass owns and operates the 69-mile-long, 42-inch-diameter natural gas sendout pipeline that was constructed in conjunction with the Golden Pass Import Terminal. The existing Golden Pass Pipeline extends from the existing terminal, generally to the west, north, and then northeast through Jefferson, Orange, and Newton Counties, Texas. The pipeline terminates in Calcasieu Parish, Louisiana (see figure 2.0-1). Associated pipeline facilities include mainline valves (MLVs) and interconnections with the NGPL, Kinder Morgan Tejas Pipeline, LLC (Tejas); Golden Triangle Storage; Texoma; Florida Gas Transmission Company, LLC (FGT); TGP; TETCO; and Transco systems. The existing Golden Pass Pipeline has an interconnection and a metering and regulation station at the existing terminal.

## **2.2 PROPOSED FACILITIES**

### **2.2.1 Terminal Expansion**

The Terminal Expansion facilities would be constructed contiguous to, and integrated with, the existing terminal (see figure 2.0-2). While Golden Pass would construct and operate the majority of the facilities within the existing Golden Pass property, the Terminal Expansion also would include about 215 acres of additional adjacent land that is privately owned. Golden Pass has not requested a change to the currently authorized size, number, or transit route of LNG carriers. No increase in the previously analyzed ship traffic is expected (see section 2.1.1).

#### **2.2.1.1 Liquefaction Facilities**

##### **Liquefaction Trains, Utilities, and Systems**

Golden Pass would use three liquefaction trains to liquefy natural gas transported to the Terminal Expansion site by the Golden Pass Pipeline, including the Pipeline Expansion. Two gas-fired turbine generators, each equipped with a heat recovery steam generator, would power each liquefaction train.

The existing Golden Pass Pipeline, which would receive gas through existing interconnections and the Pipeline Expansion (see section 2.2.2), would transport natural gas (feed gas) to the liquefaction facilities at the expanded terminal. The liquefaction facilities would consist of three liquefaction trains, each composed of a natural gas pre-treatment unit, heavy hydrocarbon removal unit, and liquefaction unit. Before liquefaction, Golden Pass would pre-treat the feed gas for removal of mercury, H<sub>2</sub>S, CO<sub>2</sub>, and water. The heavy hydrocarbon removal unit would then remove components in the feed gas such as pentane, hexane, and benzene. During the heavy hydrocarbon removal process, hydrocarbons lighter than pentane (i.e., methane, ethane, propane, and butane) would either be recycled to the beginning of the liquefaction process (described below) or routed to the fuel gas system. The heavier hydrocarbons (i.e., pentane and hexane, also known as stabilized condensate) that could freeze in the liquefaction process would be sent to the condensate storage, and a third party would transport it offsite by truck.

After being treated to remove the contaminants and heavy hydrocarbon components, the liquefaction process would condense the natural gas into a liquid at -260 degrees Fahrenheit (°F). The liquefaction process would primarily consist of the Main Cryogenic Heat Exchanger, refrigeration units, and the End Flash Gas system. Golden Pass would use nitrogen, methane, ethylene, and propane as mixed refrigerants to liquefy the natural gas. The End Flash Gas system would produce fuel gas for the turbines. Liquefaction utility components would include a boil off gas (BOG) system, fuel gas system, hot oil system, flares, instrument and utility air systems, and a demineralization water unit. The liquefaction process would generate BOG from the transfer of heat in system components that would be diverted to three new BOG compressors within the existing terminal. The fuel gas system would receive compressed BOG, with excess

BOG recycling back through the liquefaction process. All three BOG compressors would operate when an LNG carrier is being loaded, and two would operate at all other times.

Golden Pass would install a flare system consisting of three flares that would support all three liquefaction trains. Two flares, one for wet gas and one for dry gas, would serve the liquefaction trains and the streams from the plant prior to pre-treatment. The third flare would be an LNG storage, low-pressure flare used for control of inert gas (CO<sub>2</sub>, nitrogen [N<sub>2</sub>], and water vapor) that would be purged from “warm” LNG carriers along with high-pressure fuel gas to aid in combustion. The flare system would be designed to also accommodate the maximum anticipated vapor releases during a process unit or site-wide emergency, as well as vapor releases during startup and shutdown operations.

### **Liquefied Natural Gas Storage**

Golden Pass would use the five existing full-containment LNG storage tanks. Each tank is sized to store a working capacity of 155,000 m<sup>3</sup> of LNG at a temperature of -256 °F and a normal operating pressure of 1 to 3 pounds per square inch gauge (psig), and each tank meets the requirements of NFPA 59A and 49 CFR 193. The tanks are constructed of a primary inner container of 9 percent nickel steel, a secondary outer container of pre-stressed concrete, a reinforced concrete domed roof, and an aluminum insulated support deck suspended from the outer container roof over the inner container. The tanks are constructed so that both the inner primary and the outer secondary containers are completely self-supporting and capable of independently containing the stored LNG. The diameter of the outer tank is about 252 feet, and the height to the top of the dome is about 173 feet above the tank base.

Under normal operating conditions, the inner tank contains the LNG. The outer tank, designed to contain 110 percent of the full contents of the inner tank, is capable of containing the LNG, as well as the vapors resulting from release of LNG from the inner container. The space between the inner container and the outer container is insulated with expanded perlite to allow the LNG to be stored at a temperature of -256°F while maintaining the outer container at near ambient temperature. The insulation under the inner container’s base is a cellular glass, load-bearing insulation that supports the weight of the inner container and the LNG. The outer concrete container is lined on the inside with carbon steel plates as a barrier to prevent moisture from the atmosphere from reaching the insulation inside the outer container. This liner also prevents vapor from escaping from inside the tanks during normal operations. The tanks are supported on a piled foundation system. To increase the safety of the tanks, connections to the tanks are through the tank roof so that failure of a line would not result in emptying the tank.

#### **2.2.1.2 Truck Unloading and Refrigerant and Condensate Storage**

Golden Pass would construct and operate a trucking facility to unload make-up refrigerant (propane and liquid ethylene) transported to the expansion site for storage and use during the liquefaction process. Golden Pass anticipates a delivery frequency of less than four trucks per month to the facility. Golden Pass would store propane in two pressurized storage tanks, each with a maximum capacity of about 200,000 gallons and would store liquid ethylene in a tank with a dedicated refrigerant system. The ethylene refrigerant storage would have a maximum capacity of 53,000 gallons.

The heavy hydrocarbon removal unit within each of the liquefaction trains would continuously produce stabilized condensate during the liquefaction process. Golden Pass would construct two low-pressure storage tanks and a truck loading facility. Condensate would be stored in the tanks prior to pick-up and delivery to third-party customers by truck (see section 2.2.1.1).

### **2.2.1.3 Power Generation**

Electrical power would be generated for the Terminal Expansion through use of both high-pressure and low-pressure steam to drive new steam turbine generators in each of the three liquefaction trains. The heat recovery steam generators, which obtain heat from the exhaust flue gas from the gas-fired turbines of the liquefaction trains, would generate steam. Each steam turbine generator would have a power generation capacity of 100 megawatts (MW).

The existing terminal is connected to the grid by a redundant system of 230-kilovolt (kV) electrical transmission lines. This system would be used to provide power for backup and startup activities. New 230-kV overhead redundant electrical lines and isolation breakers would be installed within the Terminal Expansion boundaries to route power from the incoming electrical transmission lines to the Terminal Expansion facilities. In addition, seven backup, diesel-fired generators to power loads such as air compressors, uninterrupted power supply, gas and fire detection, emergency/egress and security lighting, fire pumps, communications, and stormwater pumps if total power outages occur when both grid power and normal generators are down or unavailable. A new 375,900-gallon diesel storage tank with secondary containment would be installed in the condensate tank and refrigerant storage area to supply the generators with fuel.

### **2.2.1.4 Supply Dock and Alternate Marine Delivery Facilities**

#### **Supply Dock**

Golden Pass would construct a supply dock along the western bank of the SNWW, about 2,000 feet east of the existing Ship Slip, for barge delivery of large equipment, construction materials, and other loads during construction and operation. The Supply Dock would consist of a barge slip extending about 400 feet into the current shoreline, with a width of about 240 feet. A 350-foot-long bulkhead would be constructed parallel to the shoreline, starting at the eastern end of the barge slip and extending to the east. The Supply Dock would be surrounded by a platform supporting crane lift operations and would include two staging areas, a 125-foot-wide heavy haul road leading from the Supply Dock to the laydown area for the liquefaction train modules, two permanent marine maneuvering dolphins just outside and northeast of the mouth of the barge slip, and four private aids-to-navigation.

The three faces of the barge slip would consist of steel sheet piles with reinforced concrete caps and fendering systems along each of the faces. The sheet pile bulkhead would be backed with an offloading platform along all three sides of the slip. The offloading platform would be a pile-supported, reinforced concrete deck extending about 60 feet from the face of the bulkhead. The purpose of the offloading platform is to accept the loads from cranes used to unload barges and the loads of self-propelled module transporters used during the roll-off of major equipment from the barges without affecting the sheet pile bulkhead.

The bulkhead section that would be parallel to the shoreline on the east side of the barge slip would consist of a sheet pile system tied to a conventional A-frame deadman structure.

At each of the two seaward corners of the Supply Dock slip, Golden Pass would install a maneuvering dolphin that would be used by tug/barge combinations during maneuvers into and out of the barge slip. The maneuvering dolphins would be monopile structures outfitted with a fendering wrap to absorb the energy of barges when they come into contact.

Golden Pass would install private aids-to-navigation in the vicinity of the 19.6-foot contour North American Vertical Datum of 1988 (NAVD 88) at the eastern and western limits of the area to be dredged in order to provide visual reference to vessel operators entering and leaving the Supply Dock area of the safe limits of water depth. The aids-to-navigation would be non-lighted floating buoys moored to the sea

floor with concrete deadweights and mooring chains. The buoys would be used only during construction and would be removed upon completion of construction.

Figure 2.2-1 provides a conceptual design for the Supply Dock. The barge slip would require dredging to a depth of -20 feet NAVD 88. Golden Pass would remove a total of about 305,750 cubic yards (yd<sup>3</sup>) of material from a 13.2 acre area to construct the Supply Dock. About 22,000 yd<sup>3</sup> (2.2 acres) would be removed via mechanical excavation from the terrestrial portion of the Supply Dock site, and about 283,750 yd<sup>3</sup> would be removed by dredging.

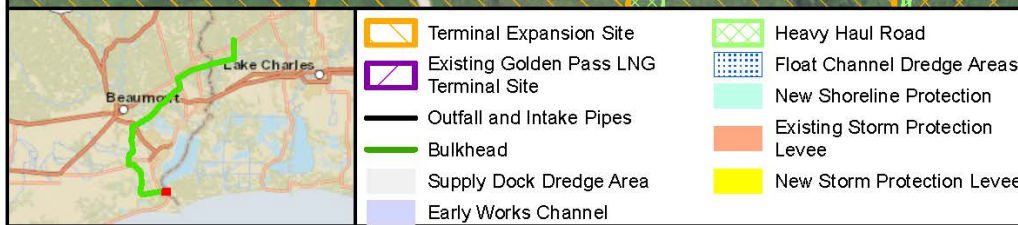
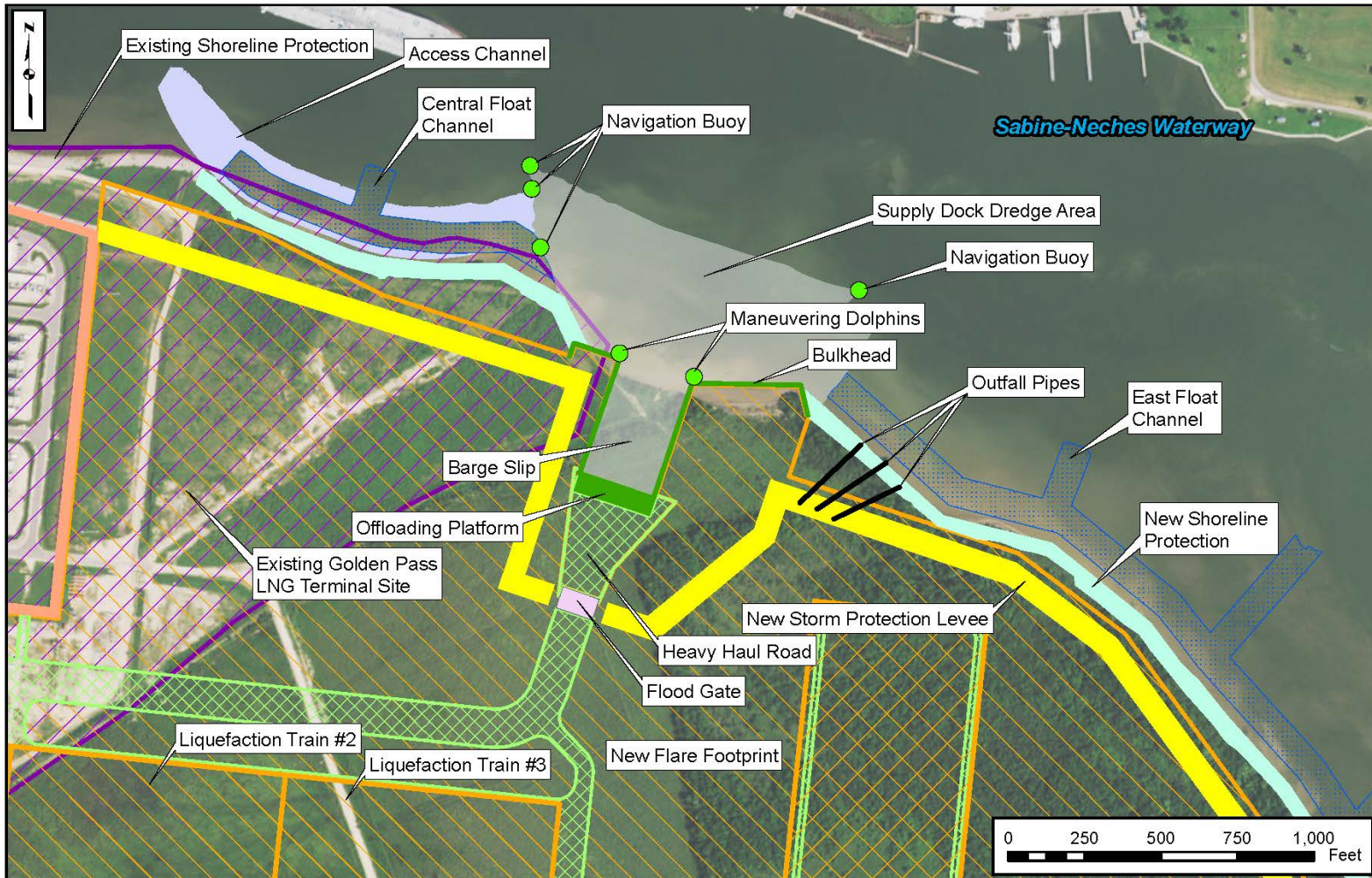
During construction of the Terminal Expansion, about two to three barges per day would deliver loads to the Supply Dock for the first 2 years, followed by one barge per day in years 3 and 4, and two barges per week after year 4 through the end of construction. A total of about 3,300 barges are anticipated to use the Supply Dock during construction. The Supply Dock would be designed primarily for construction support but would remain in place after construction to support operations.

### **Use of a Barge as a Docking Facility during Construction**

Prior to commissioning of the Supply Dock, barges would deliver materials (e.g., soil and piping) to the Terminal Expansion site at an unimproved barge landing site located in an access channel. The unimproved barge landing site would be along the shoreline immediately west of the Supply Dock and east of the terminus of the existing shoreline protection revetment. Golden Pass would dredge or excavate the access channel about 14 feet deep and 200 feet wide parallel to the SNWW shoreline and position a barge within that area to be used as a floating dock. Delivery barges would be towed to the site and moored or held in place by an assist tug. Equipment and material would be offloaded from the barges and transported to storage areas or work sites. Golden Pass would place a ramp from the shoreline to each barge, to allow trucks to drive down to the barges and be loaded while on the barge or the ramp. In addition, Golden Pass would perform a slope stability survey at the barge landing site and make improvements to the shoreline, as needed, so that in some cases delivered materials could be placed on the shoreline during the transfer process.

Golden Pass would continue to use the barge landing site after completion of the Supply Dock to alleviate any construction-related marine traffic at the Supply Dock. The access channel would be dredged or excavated on an as-needed basis for the duration of construction of the Terminal Expansion. Golden Pass proposes to dispose of dredged material in one of two dredged material placement areas (DMPAs) managed by the COE and located within 6 miles of the Terminal Expansion on the SNWW. Selection of the specific DMPA to be used would depend on factors such as the available volume of disposal area within the DPMA at the time of dredging, coordination with the COE, and the results of testing for contaminated sediments within the dredged materials.

Barges would access the Supply Dock during construction and operation using several potential transit routes before entering Sabine Pass and the SNWW. Transit routes are described further in section 4.9.6.1.



**Figure 2.2-1**  
**Golden Pass LNG Export Project**  
Supply Dock

## **Use of Existing Ship Slip during Construction**

Golden Pass may use the existing Ship Slip for delivery of granular materials (i.e., soil and sand) prior to construction of the Supply Dock. This would require installation of four temporary mooring dolphins and four temporary breasting dolphins<sup>13</sup> that would be used to moor the transport ships within the Ship Slip. Additionally, two permanent mooring dolphins and four permanent breasting dolphins would be installed, all of which would remain in place during operation. Materials would be offloaded from barges or other support vessels and transported to storage areas or work sites.

### **2.2.1.5 Modifications to Existing Terminal Facilities**

Several minor modifications to the facilities at the existing terminal are proposed as part of the Terminal Expansion. These modifications consist of the following:

- installation of three BOG compressors within the footprint of the existing terminal;
- replacement of two existing pumps in each of the five LNG storage tanks with a larger operations pump and a larger spare pump to meet the LNG loading requirements;
- replacement or repurposing of some LNG tank piping to facilitate LNG loading operations;
- modification of the existing LNG transfer arms on the marine berths to allow for loading of the LNG vessels;
- installation of a total of eight temporary marine dolphins (four mooring dolphins and four breasting dolphins) along the south head of the existing Ship Slip to facilitate transfer of granular materials during construction;
- installation of a total of six permanent marine dolphins (two mooring dolphins and four breasting dolphins) along the east and west marine berths of the existing Ship Slip to facilitate potential future expansion of the facilities for LNG barge loading;
- replacement of a vent with a low-pressure flare;
- relocation of the controls and operations building to serve as a joint control room with the Terminal Expansion;
- modification of existing pipeline metering; and
- potential modification of the existing firewater system to accommodate facility changes associated with the Terminal Expansion.

### **2.2.1.6 Associated Infrastructure**

Infrastructure associated with the Terminal Expansion would include improvement of the access roads, installation of four new outfall pipes, expansion of the existing storm protection levee, additional shoreline protection systems, and construction of new firewater intake facilities.

#### **Access Roads**

There are currently two access roads to the existing terminal: the paved main entrance road that enters the facility from the west and a road with a crushed-rock (limestone) surface that enters the facility from the south from SH-87. Golden Pass would realign the main entrance road and pave it to a width of

---

<sup>13</sup> Mooring dolphins are used to “moor” or fasten a vessel at the Ship Slip—lines extend between the vessel and the mooring dolphins to keep the vessel in place. Breasting dolphins serve to absorb impact from a vessel that is mooring at the Ship Slip so that the pier or dock that the vessel is mooring adjacent to is not damaged by the vessel.



30 feet. Golden Pass does not anticipate improvements for the existing portion of the main entrance access road that does not need to be re-aligned.

The crushed-rock south-entrance access road from SH-87 would be resurfaced or topped with additional crushed rock; the road would not be widened. Golden Pass would clear the existing drainage ditches along the road of overgrowth.

### **Outfall Pipes**

Four new outfall pipes would be installed:

- a 36-inch-diameter clean stormwater pipe;
- an 8-inch-diameter treated sanitary wastewater pipe;
- a 4-inch-diameter treated wastewater pipe; and
- a 4-inch-diameter treated process wastewater pipe.

The clean stormwater, treated sanitary wastewater, and treated wastewater outfall pipes would be generally collocated along the existing shoreline to the east of the Supply Dock. They would extend beneath the new revetments described below into the SNWW a distance sufficient to provide a clear discharge point relative to the natural grade of the embankment (i.e., about 100 feet for the clean stormwater pipe, 150 feet for the treated sanitary wastewater pipe, and 175 feet for the treated wastewater pipe). The treated process wastewater outfall pipe would be located at the north end of the east berth within the existing Ship Slip. The outfall would be fastened to a piling at a water depth of -15 feet (NAVD 88). The locations of the outfall pipes are depicted in figure 2.0-2.

### **Storm Protection Levee**

Golden Pass would expand the storm protection levee system to accommodate the new liquefaction facilities and the MP 1 Compressor Station. The majority of the expanded storm protection levee would be an earthen trapezoidal design, about 10 feet wide at the crest of +16 foot (NAVD 88) elevation. The levee would have a 2.5:1 (horizontal: vertical) slope, with rip-rap armoring on the side facing the SNWW and grass covering all other sides. In addition, Golden Pass is considering removing portions of the existing levee system that would be made obsolete by installation of the new Terminal Expansion storm protection levee system. Removal of these “interior” levee structures would promote access within the new facility.

One road crossing would be installed along the new western storm protection levee and would cross it at the crest. One steel roller flood gate, about 30 feet wide, would be installed in the southern portion of the new levee to allow vehicular access to the Terminal Expansion. The gate would seal at the base sill and on both sides when closed for storm events. A second flood gate would be installed to allow transport of construction materials and equipment from the Supply Dock to the new facilities via the heavy haul road. This flood gate would be in the vicinity of the Supply Dock in the northeast portion of the new levee. It would be a steel roller gate about 125 feet wide that would also seal along the sill and on both sides when closed for storm events.

### **Shoreline Protection**

Golden Pass would expand the existing shoreline protection system by constructing about 5,500 feet of new rock revetment to stabilize the actively eroding shoreline. The new shoreline protection would extend about 1,400 feet west of the existing Ship Slip and 4,100 feet east of the existing Golden Pass Import Terminal site (see figure 2.2-1). This would not include the length of shoreline where the Supply Dock and adjacent bulkhead would be located. This system would be installed to stabilize the eroding

shoreline and provide greater than 25-year storm protection. In general, the shoreline protection would include an armor stone layer about 4 feet thick and an 18-inch-thick stone bedding layer and geotextile fabric. Revetment slopes would be designed to a slope of 3:1 and a toe side slope of 2:1. In some areas, a 2-foot-thick layer of smaller rip-rap would be extended to the existing grade on a slope of 2.5:1.

### **Firewater Intake Facilities**

Golden Pass would construct a new firewater pump and intake pipeline and associated structures to replace the existing emergency backup firewater intake system. The location of the intake system is depicted in figure 2.0-2. The new system would be used for both the existing and new facilities at the terminal. The new firewater pump would be within a reinforced concrete vault, about 20 feet wide and 25 feet long, sited on land adjacent to the eastern LNG carrier berth. The system would include a 60-inch-diameter pipe that would extend offshore from above grade at the pump structure to the point where the invert elevation of the pipe (i.e., the elevation of the inside bottom of the pipe) would be at about -15 feet (NAVD 88). This would provide about 10 feet of water above the top of the pipe at the inlet point. The inlet end of the firewater intake pipe would be fitted with double screens to prevent debris from entering with the water. Golden Pass anticipates that the flow rate for the firewater intake pipe would be 4,500 gallons per minute (gpm) to support operation of an individual firewater pump. Assuming an effective flow area of about 19.6 square feet for the 60-inch-diameter pipe, the intake water velocity is expected to be about 0.5 foot per second.

The pipeline would be supported by three, three-pile jacket structures situated between the water inlet end of the pipe and the point where the pipe penetrates the cut slope of the eastern LNG berth. The top of the support structures would be established at an elevation of about +5 feet (NAVD 88) and topped with a jacket cap that would tie the three jacket structures together and serve as the support mechanism for a walkway and a recycle discharge line between the shoreline and the end of the intake structure. The walkway on the jacket cap would be constructed of structural steel and steel bar grating, and extend from a reinforced concrete abutment installed on land where the cut slope begins from the existing grade elevation (about +8 feet [NAVD 88]) to the end of the firewater intake pipe. Golden Pass would install a service platform at the end of the walkway to accommodate periodic cleaning of the intake pipe screens. The platform would be constructed on the outermost pipe support structure and would be about 10 feet wide.

Some of the associated infrastructure improvements would require placement of fill material in wetlands. The anticipated short- and long-term wetland conversion related to the Terminal Expansion and individual wetland effects are described in section 4.4.

## **2.2.2 Pipeline Expansion**

Golden Pass proposes to construct and operate new pipeline facilities to enable bi-directional (north/south) flow capability. The flow capacity would have a maximum rate of 2.7 bcfd of domestic natural gas to or from the expanded terminal. In addition to a new pipeline loop, construction of the Pipeline Expansion would include aboveground facilities, access roads, and a pipe storage and contractor yard.

### **2.2.2.1 Pipeline**

The Pipeline Expansion would include about 2.6 miles of new 24-inch-diameter pipeline in Calcasieu Parish, Louisiana. The expansion would extend from an interconnection with a surface facility operated by TETCO near MP 63 of the existing Golden Pass Pipeline to a new compressor station near a surface facility operated by TGP near MP 66 (see figures 2.0-3 and 2.0-4 and appendix B). Golden Pass would construct its Pipeline Expansion within or parallel and adjacent to the existing Golden Pass Pipeline right-of-way for 100 percent of the pipeline route. Where feasible, the pipeline would be installed 25 feet from the existing pipeline.



The pipeline would be operated at a maximum allowable operating pressure (MAOP) of 1,480 psig, which is the same as the MAOP of the existing pipeline.

### **2.2.2.2 Aboveground Facilities**

Aboveground facilities associated with the Pipeline Expansion consist of three new compressor stations, two new pig launchers/receivers,<sup>14</sup> one new MLV, and two new tee and tap valves. Additionally, five existing interconnection facilities and two existing pig traps would be modified.

#### **Compressor Stations**

Golden Pass would construct three new compressor stations, with a total of about 120,000 hp, to facilitate the receipt and delivery of a maximum of 2.7 bcf/d of natural gas supply to the Terminal Expansion. The locations of the compressor stations are depicted in figures 2.0-3 and 2.0-4. The compressor stations would include manifolds for suction and discharge, vent lines, scrubbers, compressor/driver units, air coolers, isolation block valves, and associated instrumentation and controls. Back-up power for each compressor station would be provided by a 500-kilowatt generator powered by natural gas from the pipeline. As a result, no fuel would be stored at the compressor stations.

The locations of the compressor stations would be as close as is practical to the existing meter stations and the existing Golden Pass Pipeline. The MP 1 Compressor Station would be immediately adjacent to the Terminal Expansion near the existing interconnection with the NGPL pipeline. The MP 33 Compressor Station would be near the existing interconnection with the Texoma pipeline. Each of these two compressor stations would consist of two compressor units, each designed for 60 percent of the maximum station flow rate of 0.75 bcf/d. The MP 1 Compressor Station would have two electrically driven, 5,583-hp turbines and the MP 33 Compressor Station would have two gas-driven, 8,997-hp turbines.

The MP 66 Compressor Station would be near the existing interconnection with the TETCO pipeline. The station would be designed with both a low-pressure and a high-pressure system. The low-pressure system would include two gas-driven, 8,475-hp turbines to mix the natural gas stream from the Transco interconnection (MP 68.5) with the natural gas streams from the TETCO and TGP interconnections (MPs 66 and 63, respectively). The high-pressure system would use five gas-driven, 15,128-hp turbines to transport gas at the MP 66 Compressor Station maximum flow rate of 1,900 million standard cubic feet per day to the existing Golden Pass Pipeline.

#### **Launchers/Receivers and Mainline Valve**

The Pipeline Expansion would include a new permanent pig launcher at the TGP interconnection at about MP 63, and a pig receiver would be installed at the MP 66 Compressor Station. One new MLV would be installed along the existing Golden Pass Pipeline at about MP 69.6. The MLV would be equipped with an actuator and control equipment, as needed. One new tap valve would be installed along the existing Golden Pass Pipeline at about MP 0.8 for discharge from the MP 1 Compressor Station to the existing pipeline.

#### **Interconnections and Metering Modifications**

Modifications would be required at five existing Golden Pass Pipeline interconnections: NGPL (MP 1), Texoma (MP 33), TGP (MP 63), TETCO (MP 66), and Transco (MP 68.5). The modifications would entail new valve arrangements to allow for bi-directional flow. Construction of the interconnections

---

<sup>14</sup> A pipeline "pig" is a device used to clean or inspect the pipeline. A pig launcher/receiver is an aboveground facility where pigs are inserted or retrieved from the pipeline.

and metering modifications would occur within the existing fenced and graveled areas, or on land associated with the existing interconnections and owned by third parties. All other equipment within the existing metering stations would be maintained to preserve the function of the existing Golden Pass Pipeline.

### **2.2.2.3 Access Roads**

Golden Pass would use four existing roads and two new roads to access the pipeline right-of-way and the aboveground facilities. Golden Pass would also use private roads to facilitate access for construction materials and vehicles to the construction right-of-way. Access roads are depicted in figures 2.0-3 and 2.0-4. Modification of the existing roads would be necessary only for the access road at MP 66, which would be widened to about 25 feet. All access roads would be maintained for permanent access after construction. Golden Pass would access the pipe storage and contractor yard (see section 2.2.2.4) using existing interstate and farm roads, with no need for modifications or improvement. The existing access road leading from the farm road to the pipe storage and construction yard would require minimal grading and graveling.

### **2.2.2.4 Pipe Storage and Contractor Yard**

Golden Pass would use one pipe storage and contractor yard during construction. The proposed site is a tract of industrial land in Orange County, Texas, about 6 miles northeast of MP 33 and about 2 miles west of the City of Orangefield. The parcel was used in the same capacity during construction of the existing Golden Pass Pipeline and would be returned to approximately pre-construction conditions after construction. The site would not be used during operation.

## **2.3 LAND REQUIREMENTS**

The Project would disturb about 1,017 acres of land and open water for construction and 838 acres for operation. Land requirements for the Project are addressed by component below and summarized in table 2.3-1.

### **2.3.1 Terminal Expansion**

Construction of the Terminal Expansion, including the Supply Dock and modifications to the existing marine berth, would affect about 919 acres (735 acres of land and 184 acres of open water). All onshore areas would be graveled or otherwise stabilized to prevent erosion. Operation of the Terminal Expansion would permanently affect about 783 acres.

### **2.3.2 Pipeline Expansion**

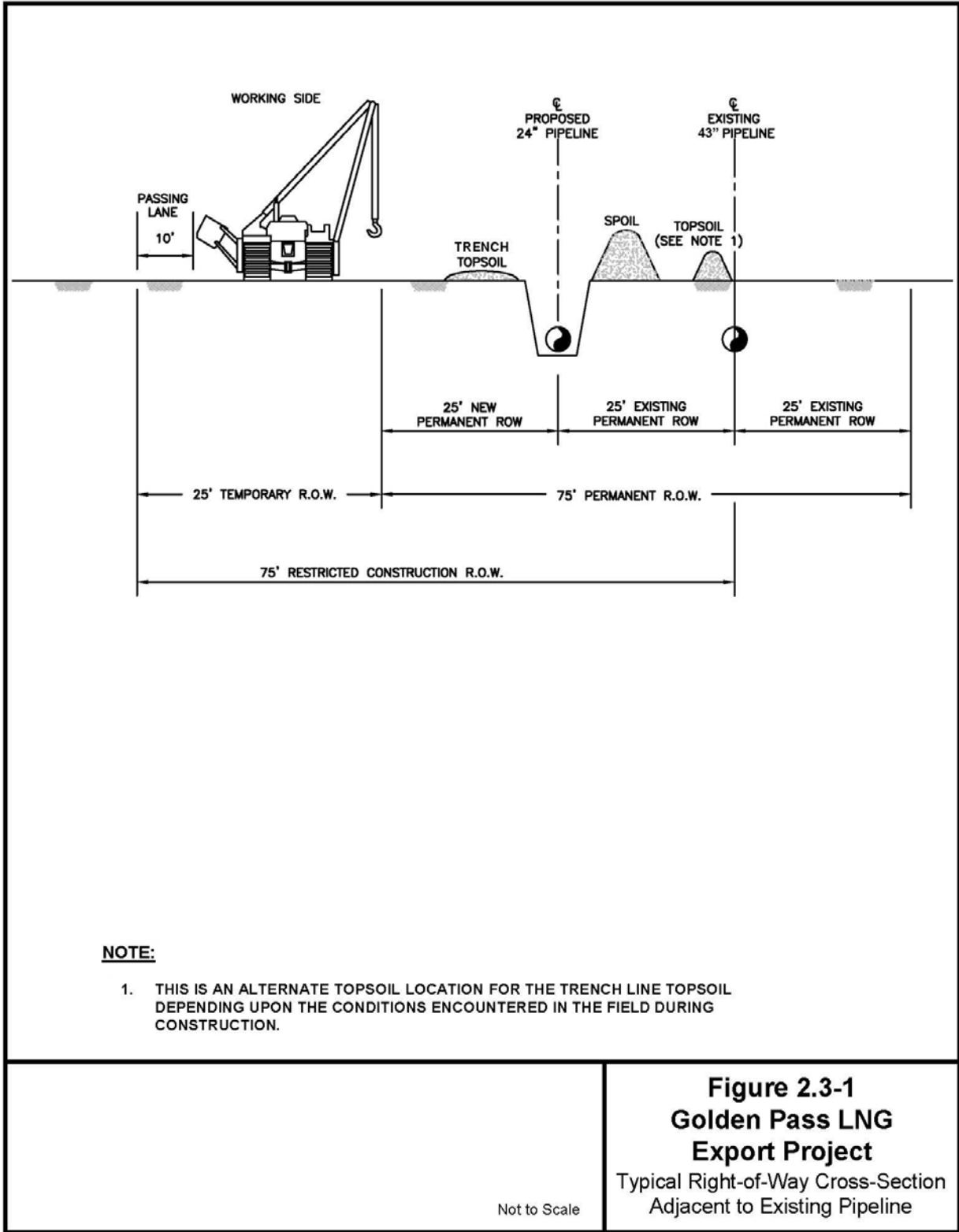
Construction of the Pipeline Expansion and associated facilities would affect a total of about 99 acres of land, with operation affecting a total of about 56 acres (about 11 acres for the permanent right-of-way for the pipeline and 44 acres for aboveground facilities).

<b>TABLE 2.3-1</b>		
<b>Land Requirements for the Golden Pass LNG Export Project</b>		
<b>Facility</b>	<b>Land Affected during Construction (acres)</b>	<b>Land Affected during Operation (acres) <u>a</u></b>
<b>Terminal Expansion</b>		
Terminal Expansion		761.4
Supply Dock	18.0	14.8
Access Road	6.6	6.6
<i>Terminal Expansion Subtotal</i>	<i>918.7</i>	<i>782.8</i>
<b>Pipeline Expansion</b>		
MP 1 Compressor Station and NGPL Interconnection	14.2	11.0
MP 33 Compressor Station and Texoma Interconnection	10.7	8.0
Tennessee Gas Interconnection (MP 63)	1.1	1.1
MP 66 Compressor Station and TETCO Interconnection	15.8	15.0
Transco Interconnection (MP 68.5)	3.0	0.8
Calcasieu Loop pipeline	22.0	11.0
Pipe Storage and Contractor Yards	13.0	0.0
Additional temporary workspace	10.0	0.0
Access Roads	8.6	8.5
<i>Pipeline Subtotal</i>	<i>98.7</i>	<i>55.6</i>
<b>Project Total</b>	<b>1,017.4</b>	<b>838.4</b>
<b><u>a</u></b> Acreage listed is within the areas used for construction.		

**2.3.2.1 Pipeline Right-of-Way and Temporary Workspaces**

**Construction and Permanent Right-of-Way**

Golden Pass proposes to use a 100-foot-wide construction right-of-way, except in the areas listed in section 2.6.3.1. The permanent right-of-way would be 50 feet wide. The right-of-way would be within or parallel and adjacent to the existing Golden Pass Pipeline right-of-way, and 25 feet of the permanent right-of-way would overlap with the existing 50-foot-wide pipeline right-of-way, resulting in a total permanent 75-foot-wide right-of-way for the two pipelines. Figure 2.3-1 depicts the typical construction right-of-way cross-section adjacent to the existing pipeline.



**Figure 2.3-1**  
**Golden Pass LNG**  
**Export Project**  
 Typical Right-of-Way Cross-Section  
 Adjacent to Existing Pipeline

Not to Scale

## **Additional Temporary Workspace**

Golden Pass would require about 10.0 acres of additional temporary workspace (ATWS) for construction at the compressor stations, wetland and waterbody crossings, and use of the horizontal directional drilling (HDD) method (described in section 2.6.3.1). HDD would be used between MP 65 and MP 66 would require about 0.7 acre of ATWS for the entry and exit pits, each of which would measure about 150 feet by 250 feet. After construction, the surface contours of the ATWS would be returned to pre-construction conditions and the areas would be allowed to revegetate. The ATWS would not be used during operation.

### **2.3.2.2 Aboveground Facilities**

Construction of the aboveground facilities would affect a total of about 44.5 acres, of which 35.9 acres would be permanently affected during operation. Table 2.3-1 identifies the land requirements for the aboveground facilities. The interconnections and appurtenant facilities would be within the compressor station sites, the existing Golden Pass Pipeline right-of-way, the Pipeline Expansion right-of-way, or the existing interconnection sites.

### **2.3.2.3 Access Roads**

Golden Pass would use about 8.6 acres of access roads for construction of the pipeline, including both existing and new access roads. All but one of the access roads would be maintained for permanent access after construction, resulting in total impacts on 8.5 acres.

### **2.3.2.4 Pipe Storage and Contractor Yard**

Golden Pass proposes to use 13.0 acres of industrial land as a pipe storage and contractor yard. A total of 38.7 acres at this site was previously used as a pipe storage and contractor yard (see figure 2.0-1).

## **2.4 CONSTRUCTION SCHEDULE**

Golden Pass anticipates constructing and placing the Terminal Expansion in service in three phases, with construction starting in 2016 (assuming receipt of all authorizations and necessary permits). Golden Pass plans to have the first liquefaction train and associated facilities completed and in service by July 2020. Construction of the second liquefaction train would begin about 6 months after initiation of construction of the Terminal Expansion, and construction of the third liquefaction train would start about 6 months after that, with full service anticipated for the third quarter of 2021.

Golden Pass would begin construction of the Pipeline Expansion in 2018 and anticipates completion in 2019, prior to completion of the first liquefaction train, with construction taking place over a period of 15 months. Golden Pass also would construct the compressor stations during that period.

## **2.5 ENVIRONMENTAL COMPLIANCE**

The FERC may impose conditions on any Certificate or authorization it grants for the Project. These conditions may include additional requirements and mitigation measures recommended in this EIS to avoid and minimize the environmental impacts that would result from construction and operation of the Project (see sections 4.0 and 5.3). We will recommend that these additional requirements and mitigation measures (presented in bold type in the text of the EIS) be included as specific conditions to any approving Certificate or authorization issued for the Project. We will also recommend that the Commission requires Golden Pass to implement the mitigation measures they proposed as part of the Project unless they are specifically modified by other Certificate or authorization conditions. Golden Pass would incorporate all

environmental conditions and requirements of the FERC Certificate and associated construction permits into the construction documents for the Project.

The FERC has established a set of construction and mitigation measures developed in collaboration with other federal and state agencies and the natural gas pipeline industry to minimize the potential environmental impacts of the construction of pipeline projects in general. These measures and procedures are presented in the 2013 FERC *Upland Erosion Control, Revegetation, and Maintenance Plan* (Plan) and *Wetland and Waterbody Construction and Mitigation Procedures* (Procedures).<sup>15</sup> Golden Pass has proposed 30 alternative measures to portions of the FERC Plan and Procedures. The FERC Plan and FERC Procedures, along with the requested variances are provided in appendices G and H, respectively, and these alternative measures are addressed in sections 4.2 and 4.3

### **2.5.1 Compliance Monitoring**

Golden Pass would employ at least one environmental inspector (EI) for the Project. FERC's Plan and Procedures include descriptions of the responsibilities of EIs. The EIs would be responsible for ensuring that the environmental obligations, conditions, and other requirements of permits and authorizations for the Project are met. The Golden Pass' EI(s) would inspect all construction and mitigation activities to ensure environmental compliance. The EI(s) may also oversee cultural resource and/or biological monitoring and evaluate construction impacts on resources as specified in this EIS.

We would also conduct field inspections during construction. Other federal and state agencies may also conduct oversight of inspection to the extent determined necessary by the individual agency. After construction, we would continue to conduct oversight inspection and monitoring during operation of the Project to ensure successful restoration. Additionally, the FERC staff would conduct bi-annual engineering safety inspections of the LNG facility operations.

### **2.5.2 Environmental Training**

Golden Pass would require that its contractors be familiar with the requirements of all environmental permits and comply with all federal, state, and local environmental regulations and ordinances that apply to construction of the facilities, including restoration of areas temporally disturbed during construction. This would be accomplished by implementation of a training program that would ensure the following:

- Qualified environmental training personnel would provide training sessions regarding the environmental requirements applicable to the trainees' activities.
- All individuals would receive environmental training before beginning work.
- Adequate records regarding the training program would be kept.
- Refresher training would be provided as needed to maintain a high awareness of environmental requirements.

---

<sup>15</sup> The FERC Plan can be viewed on the FERC Internet website at <http://www.ferc.gov/industries/gas/enviro/plan.pdf>. The FERC Procedures can be viewed on the FERC Internet website at <http://www.ferc.gov/industries/gas/enviro/procedures.pdf>.

## **2.6 CONSTRUCTION PROCEDURES**

Golden Pass proposes the following construction methods, which include measures intended to avoid or minimize environmental impacts during construction.

### **2.6.1 Terminal Expansion**

#### **2.6.1.1 Site Preparation**

Initial site preparation would include expansion of the storm protection levee system. Expansion of the existing storm protection levee would entail extending the existing levee system to also encompass the Terminal Expansion. The expanded levee would have a height of 16 feet above mean lower low water (thereby exceeding the 100-year flood level). Golden Pass would modify the existing terminal's stormwater management system to account for the increased area within the levee. Some land within the levee would be maintained and used for equipment storage and turn-around support. Some portions of the existing storm protection levee system would not be modified, although Golden Pass is considering removing portions of the existing levee system that would be inside the expanded portions of the levee system after the storm protection levee expansion is complete.

Site preparation of the Terminal Expansion site would include clearing of all construction work areas of shrubs, trees, and other obstructions. In accordance with FERC's Plan, Golden Pass would install temporary erosion controls immediately after initial disturbance of the soil to minimize erosion and maintain these controls throughout construction or until permanent erosion control measures are installed. The site would be graded and filled where necessary to create a reasonably level working surface to allow safe passage of construction equipment and materials. Golden Pass would use about 2.5 million yd<sup>3</sup> of imported fill, consisting of rock, soil, and crushed limestone, to establish the desired grade level for the Terminal Expansion site. An additional 1.0 million yd<sup>3</sup> of fill would be used for an expansion of the existing terminal's storm protection levee.

Initial site preparation for expansion of the shoreline protection system would entail clearing and grading the shoreline where the new revetment would be installed. The construction methods for the revetment are described in section 2.6.1.7.

#### **2.6.1.2 Terminal Piping and Equipment Installation**

Concrete and fill material would be delivered to the site on an as-needed basis, thus precluding the need for on-site batching or storage. The major equipment for the liquefaction trains and other systems would require specialized materials, equipment, and construction techniques; some of this equipment would be prefabricated at off-site specialty manufacturing and prefabrication locations. All foundations for major equipment and structures would be placed on pile foundations.

Upon completion of the site preparation activities, Golden Pass would initiate construction of the foundations, pipe racks, liquefaction trains, flares, major mechanical equipment, buildings, process and utility piping, electrical components, and instrumentation. Underground piping would be installed first. Golden Pass would install any necessary underground pipe and utilities (e.g., electrical conduits) about 3 feet below the finish grade. This would be followed by construction of foundations, including piling necessary for the buildings, major equipment, and pipe racks. Next, the pipe racks would be completed, followed by installation of process and utility piping and cable trays; setting of the major equipment; and establishment of piping, electrical, and instrumentation tie-ins.

About 25,000 piles would be required for the Terminal Expansion, including about 100 offshore piles for the firewater intake trestle (see section 2.6.1.9). The types of piles used would include steel pipe

piles, precast concrete piles, and potentially displacement piles. The depths to which the piles would be driven would range from 100 to 150 feet, depending on the load and pile capacity required. The steel and precast concrete piles would initially be driven using a vibratory hammer pile driver until refusal, then driven to final depth using a hammer pile driver. Displacement piles would be drilled.

Upon completion of the piping systems, Golden Pass would ensure the integrity of the pipes through non-destructive and hydrostatic or pneumatic testing in compliance with the applicable codes governing pipe design. The source of the hydrostatic test water would either be municipal supplies or purchased water. Prior to discharge, Golden Pass would test the hydrostatic water in accordance with the Railroad Commission of Texas' (RCC) Hydrostatic Test Water Discharge Permit, which requires testing for pH, and oil and grease, as well as monitoring of the discharge water for visible sheen.

After hydrostatic testing is completed, instrumentation and electrical loop testing and pre-commissioning activities would be completed.

### **2.6.1.3 Existing Ship Slip**

Annual maintenance dredging would continue to be conducted at the existing Ship Slip as authorized by an existing COE permit. However, during construction of the Terminal Expansion, Golden Pass would use dredged material from maintenance dredging of the existing Ship Slip for wetland mitigation (see section 4.4). Following this one-time use of dredged material, any other maintenance dredging materials from the existing Ship Slip would be disposed of as required in Golden Pass' existing COE permit.

### **2.6.1.4 Supply Dock**

Golden Pass would install the Supply Dock during the early stages of construction to allow for the transfer of large equipment and significant volumes of materials to the Terminal Expansion construction site. The Supply Dock barge slip would be dredged and excavated out of the unimproved shoreline about 2,000 feet east of the existing Ship Slip and within the property boundary of the existing terminal. The design depth at the front face of the barge slip would be -20 feet (NAVD 88), resulting in the excavation of about 305,750 yd<sup>3</sup> of substrate. About 22,000 yd<sup>3</sup> of substrate would be removed via mechanical excavation from the landward edge of the barge slip, and the remaining 283,750 yd<sup>3</sup> would be removed via hydraulic dredge from a barge at the seaward edge of the barge slip. Golden Pass would dispose the dredged sediments in accordance with the requirements of its pending COE permit. About 800 precast concrete piles would be installed to support the Supply Dock platform and bulkhead. The piles would be driven to depths ranging from 100 to 150 feet, depending on load and pile capacity requirements. The piles would initially be driven using a vibratory pile driver until refusal, then driven to final depth using a hammer pile driver. Golden Pass anticipates installing the majority of the piles using shore-based equipment, with about 10 piles situated offshore and driven from a barge.

The heavy haul road extending from the Supply Dock would be about 125-foot-wide and 3,700-foot-long. It would be constructed with an 18-inch-deep stone base and a geotextile fabric lining.

### **2.6.1.5 Site Restoration**

All construction areas, including construction laydown areas but not including the over-water workspace within the SNWW, would be graveled or otherwise stabilized to prevent erosion. The graveled areas in the area enclosed by the storm protection levee system would remain in a graveled state after construction, and the permanent operational footprint within the terminal property boundary would be gravel or asphalt. Construction workspace outside of the bounds of the storm protection levee would be allowed to revegetate naturally, in accordance with FERC's Plan and Procedures.



### **2.6.1.6 Breasting and Mooring Dolphins**

The four new breasting dolphins at the existing Ship Slip would consist of three-pile, jacketed pipe structures outfitted with panel fender systems to absorb the berthing energy of the vessel. The piles would be large-diameter, concrete-filled steel pipe pile with a pipe bollard cast into the top of the dolphin. Construction of the breasting and mooring dolphins is anticipated to be conducted using conventional marine-based equipment, including barge-mounted cranes and pile driving hammers (vibratory and/or impact hammers). The breasting and mooring dolphins would be removed down to the mudline when construction is completed.

### **2.6.1.7 Storm Protection Levee Installation**

After any required grubbing, geogrid and/or geotextile fabric would be placed along the footprint of the levee. Golden Pass' current engineering design recommends that lime-stabilized clay material be placed from elevation +1 foot above grade to elevation +5 feet above grade. Lime-stabilized clay material would be transported by dump truck, and rollers would spread and compact the clay material in about 8- to 12-inch-high lifts.

Once the levee height reaches +5 feet above grade, the levee material would transition to clay fill. As the levee height increases, Golden Pass would establish dump on/off-ramps for use by the dump trucks depositing the clay fill. Golden Pass anticipates that the levee would be constructed in segments about 1,000-feet-long. To ensure the integrity of the levee, some overlapping of the lifts would be required (similar to laying bricks, where the joints do not line up). An access road along the levee interior and/or exterior may be required for trucks to complete the return cycle. This iterative cycle of dumping material, spreading, and compacting would continue until the design elevation of +16 feet (NAVD 88) is reached.

Modifications to the existing levee system would focus on ensuring that the levee height is maintained at the design elevation of +16 feet (NAVD 88). The existing levees are relatively narrow at the top, precluding travel by trucks and other heavy machinery. Thus, any modifications to the existing levee system would be conducted with smaller machinery and hand-held equipment. The tops of the existing levees would be scarified to ensure bonding of new clay material. Once material is placed, it would be compacted in place until the design elevation of +16 feet (NAVD 88) is met.

The materials required for the storm protection levee would be obtained from commercial borrow sources. Prior to construction, Golden Pass would identify the commercial borrow material source(s) based on the fill material specifications.

### **2.6.1.8 Revetment Installation**

Initial site preparation would result in a total of about 60,000 yd<sup>3</sup> of material being removed from the shoreline. About 45,000 yd<sup>3</sup> of imported material, consisting of about 60,000 tons of armor stone and 30,000 tons of bedding stone, would be used for new revetment construction. At some locations, an additional 5,000 tons of stone would be required for rip-rap at the top of the graded slope.

Revetment construction could be accomplished either from upland areas using land equipment or from the water using marine equipment, or by a combination of the two. The upland construction method would require stone materials to be trucked to the site. Sources of quality stone materials are not available near the Project site; potential stone sources for the upland construction method are in the Austin, Texas area, and stone materials would be transported by truck or rail to Port Arthur. Equipment used to construct the revetment from the upland areas would likely include excavators, front end loaders, and dump trucks.

Revetment construction using marine equipment and delivery of stone materials via barges is also feasible and common in the Sabine River area. The marine construction method would require dredging temporary channels (east, central and west float channels and the access channel) roughly parallel to the shoreline in order to allow the marine equipment to reach the shoreline. Marine equipment used to construct the revetment would likely include construction crane barges, excavators, and material barges. Golden Pass estimated the maximum volume of dredged material from the temporary float and access channels to be about 150,000 yd<sup>3</sup>. Golden Pass would dispose the sediments excavated in accordance with the requirements of its pending COE permit.

Considering the high erosion rates, steep embankments, and variable nature of the shoreline, Golden Pass would determine the specific construction methods based on the conditions of the shoreline at the time of construction. Access and equipment staging sites would be identified and submitted for agency approval prior to commencement of construction. Final staging areas and construction methods would depend on contractor needs and permit conditions.

#### **2.6.1.9 Outfall Pipes**

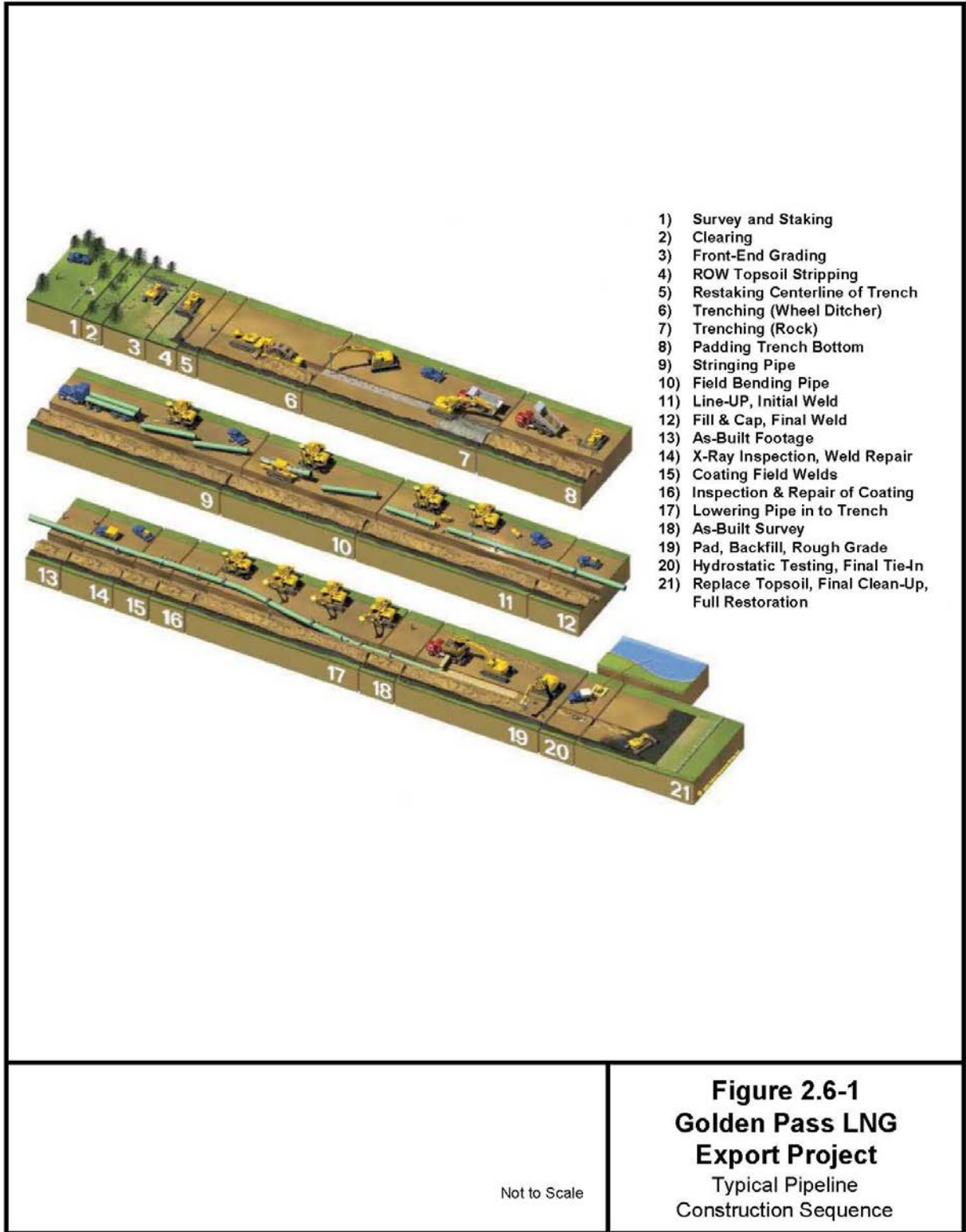
As noted in section 2.2.1.7, three of the four new outfall pipes would be generally collocated east of the Supply Dock and would extend beneath the new shoreline protection revetment into the waterway. Using anchor bolts, Golden Pass would found the offshore end of the each outfall pipe on a reinforced concrete pad installed within the waterway. The pads would be installed from the shoreline. In addition, a concrete mattress would be installed over the exposed portion of each outfall pipe to enhance the lateral stability of the pipe and protect it from debris. Warning markers would be installed adjacent to the exposed portion of each outfall pipe. The fourth outfall would be collocated with the eastern berth of the Ship Slip at a depth of -15 feet (NAVD 88).

#### **2.6.1.10 Firewater Intake Facilities**

The firewater intake pipe would be installed using conventional trenching methods coupled with cofferdams in the offshore portions where it penetrates the cut slope for the eastern LNG carrier berth. From the point where it penetrates the cut slope, it would be supported by three, three-pile jacketed structures. The center vertical pile would be driven first. The jacket would be placed on the pile and secured in place. Once the jacket is secured, the two piles on opposite sides of the center pile would be placed through their jacket sleeves and driven. The outer two piles would be battered piles to provide lateral stability for the intake pipe. The support structures would be installed using a work barge outfitted with a crane and a pile driving hammer. The top of the support structures would be established at an elevation of about +5 feet (NAVD 88) and topped with a jacket cap to connect the tops of the jacket structure. About 100 piles would be needed to construct the facility.

#### **2.6.2 Pipeline Expansion**

Golden Pass would construct the pipeline and associated facilities in accordance with FERC's Plan and Procedures, and in compliance with the requirements of 49 CFR 192 (Transportation of Natural and Other Gas by Pipeline: Minimum Federal Safety Standards). Key aspects of construction are described below, and figure 2.6-1 depicts the typical pipeline construction sequence.



### **2.6.2.1 Marking the Right-of-Way**

Prior to clearing the right-of-way, a civil survey crew would stake the centerline of the pipeline route and the boundaries of the construction right-of-way. Golden Pass would contact the “Call before You Dig” or “One Call” system to verify and flag utilities along the construction right-of-way and would flag environmentally sensitive areas (e.g., wetlands).

### **2.6.2.2 Clearing and Grading**

Golden Pass would clear and grade the construction right-of-way and ATWS where necessary to provide a relatively level surface for trench-excavating equipment and movement of other construction equipment. This would include clearing brush, trees, and roots. Golden Pass would preserve natural drainage patterns to the extent practical and would install temporary erosion controls immediately after initial disturbance of the soils where necessary to minimize erosion. The temporary erosion control measures would be maintained during construction.

Where fences cross the right-of-way, they would be cut, braced, and temporarily fitted with gates, to permit passage of construction equipment while maintaining current livestock barriers and to limit public access to the right-of-way.

### **2.6.2.3 Trenching**

In upland areas, Golden Pass would install the majority of the pipeline using conventional open-cut methods, which typically include the steps described below. Specialized construction procedures, such as those used for installation of the pipeline across wetlands, are described in section 2.6.3.

The trench would be excavated to a depth that would allow coverage of the pipeline to meet or exceed DOT standards at 49 CFR 192.327. Typically, the trench would be about 8 feet deep (to allow for about 3 feet of cover), about 12.5-foot-wide in stable soils, and up to 25-foot-wide at the top in unstable (e.g., high water content) soils. Additional trench width may be required to maintain the stability of trench walls for the safety of pipeline workers and equipment. Excavated material would be stored on the right-of-way next to the trench, on the opposite side of the working area. No blasting is anticipated for pipeline installation.

In cultivated or rotated agricultural lands, and in some other areas as requested by the landowner, Golden Pass would excavate a maximum of 12 inches of topsoil and maintain it in stockpiles that would be separate from the stockpiles of excavated subsoil.

To manage stormwater surface flow, Golden Pass would leave gaps in the stockpiled excavation materials and use diversion structures to manage cross drainage needs. Gaps in windrowed spoil (and topsoil piles) would allow surface water to migrate across the construction right-of-way to minimize up-gradient flooding and downstream sedimentation. Gaps would be left at regular intervals or where appropriate due to site conditions. Where stormwater runoff flows are a concern, Golden Pass may install flume pipe (i.e., appropriately sized pipe constructed of steel, polyvinyl chloride [PVC], or other appropriate material) or diversion berms or ditches to direct stormwater across the trench and away from the construction right-of-way.

On sloping terrain, Golden Pass may use soft and hard trench plugs to prevent water from scouring the bottom of the trench line. Both types of plugs would be made of earthen material: soft plugs would be excavated prior to backfill and the material re-compacted in the trench; hard plugs would not be excavated prior to backfilling.

#### **2.6.2.4 Pipe Stringing, Bending, and Welding**

Golden Pass would deliver pipe segments to the construction right-of-way and string the pipe segments, which would involve positioning pipe sections on temporary supports along the prepared right-of-way parallel to the centerline of the trench. Pipe sections would be strung on the working side of the trench for bending, welding, coating, and lowering-in operations and the associated inspection activities.

Field bends of the pipe would follow the natural grade and direction changes of the right-of-way and would be accomplished using a mechanical pipe bending machine. Where sharp bends of pipe are required, the bends would be made at the manufacturing plant. Following stringing and bending, the ends of the pipe sections would be aligned and welded together. All welding would be conducted by qualified welders as specified in 49 CFR 192. Golden Pass would visually inspect and test the welds to ensure structural integrity using non-destructive examination methods such as radiography (x-ray) or ultrasonic testing. Golden Pass would repair or replace any welds that do not meet DOT's safety standards in 49 CFR 192. Golden Pass would maintain records of welds, including repairs and cut-outs, that contain the identification serial number, weld location, date produced, and names of welders.

A factory-applied, fusion-bonded epoxy external coating would cover and protect the delivered pipe sections from corrosion. After welding, Golden Pass would coat the ends of the pipe at all joints with a material compatible with the factory-applied coating in preparation for installation. Golden Pass would then inspect the coating, both visually and electronically, and repair any damaged coating prior to lowering the pipe into the trench.

#### **2.6.2.5 Lowering-in and Backfilling**

Prior to lowering the pipeline into the trench, Golden Pass would remove debris and foreign material and dewater the trench as necessary. Golden Pass would pump accumulated groundwater or rainwater from the trench to stable upland areas in accordance with applicable federal, state, and local permitting requirements and FERC's Procedures. If necessary, dewatering effluent would pass through sediment filters and energy-dissipating devices to minimize sediment deposition and scour.

Golden Pass would lower the pipeline into the trench using sideboom tractors working in unison to avoid buckling of the pipe. Trench breakers would be installed, where appropriate, to prevent subsurface erosion and flow of water between the trench and crossed wetlands or near-surface groundwater.

After the pipeline is lowered into the trench and adequately protected, backfilling would begin. The trench would be kept open the minimum time necessary, subject to construction contractor plans, weather, and the duration of the weld testing. Golden Pass would use previously excavated materials to backfill the trench. If the excavated material has significant amounts of rock that could damage the pipe coating, Golden Pass would install a rock shield, obtain commercial fill for padding, or separate rocks from suitable material from the excavated trench spoil. Any excess rock deemed unsuitable for backfill would be disposed of in accordance with applicable regulations and landowner requests. Topsoil would not be used for padding. In areas where topsoil has been segregated, Golden Pass would place the excavated subsoil into the trench first and top it with the topsoil. Backfilling would occur to existing grade or higher to accommodate future soil settlement.

#### **2.6.2.6 Hydrostatic Testing**

Once installation and backfilling are completed, Golden Pass would hydrostatically test the pipeline in accordance with DOT safety standards (49 CFR 192) to verify its integrity and ensure its ability to withstand the MAOP. Hydrostatic testing consists of installing a hydrostatic test cap and manifold, filling the pipeline with water, pressurizing the pipeline to 125 percent of its MAOP, and maintaining that test

pressure for a minimum of 8 hours. If the pipeline is tested in segments, Golden Pass proposes that the test water may be pumped to the next pipe segment for use in testing, or the water may be discharged within the construction right-of-way through an energy-dissipating device, or discharged as otherwise directed by permit stipulations. Prior to discharge, Golden Pass would test the hydrostatic water in accordance with the LDEQ's Hydrostatic Test Water Discharge Permit, which requires testing for oil and grease and pH, and monitoring of the discharge water for visible sheen.

If either leaks or loss of pressure are detected during the test, Golden Pass would excavate, remove, replace, and re-test the flawed segment. Section 4.3.2.2 provides additional information on hydrostatic testing.

#### **2.6.2.7 Pre-Commissioning**

After completion of hydrostatic testing, Golden Pass would clean and dry the pipeline with pigs that would be propelled using compressed air. The pipeline would then be packed with nitrogen or other appropriate gas that would remain in place until the pipeline is put into service.

#### **2.6.2.8 Cleanup and Restoration**

After the trench is backfilled, Golden Pass would compact the trenchline with tracked construction equipment to minimize settling and would remove all remaining debris, surplus materials, and temporary structures and dispose of them in accordance with applicable federal, state, and local regulations. Golden Pass proposes to finish grade and restore all temporarily disturbed areas as closely as practicable to pre-construction contours within 20 days after backfill as specified in FERC's Plan, depending on weather conditions. During this phase, Golden Pass would also install permanent erosion control measures in accordance with FERC's Plan and Procedures.

Golden Pass would reseed the right-of-way after pipeline installation in accordance with FERC's Plan. We would inspect the right-of-way after the first and second growing seasons to determine the success of revegetation. Golden Pass would implement additional restoration measures if deemed necessary by the FERC and/or other federal, state, or local agencies.

Finally, Golden Pass would install pipeline markers and/or warning signs along the pipeline centerline at line-of-sight intervals to identify the pipeline location, identify Golden Pass as the pipeline operator, and provide telephone numbers for emergencies and inquiries. In accordance with 49 CFR 192, Golden Pass would install a cathodic protection system to prevent or minimize corrosion of the buried pipeline and aboveground facilities. The cathodic protection system impresses a low-voltage current on the pipeline to offset natural soil and groundwater corrosion potential.

### **2.6.3 Special Construction Procedures**

#### **2.6.3.1 Waterbody and Wetland Crossings**

Three minor waterbodies would be within the Pipeline Expansion impact area: two roadside ditches and an agricultural ditch. The roadside ditches would be permanently filled. The agricultural ditch would be crossed using an open-cut method. The special methods Golden Pass would use to cross waterbodies and wetlands are described below.

##### **Open-cut Waterbody Crossing Method**

It is expected that the agricultural ditch at about MP 64 of the Pipeline Expansion will contain water at the time of crossing. In this case, Golden Pass would use the wet open-cut method in accordance with

FERC's Procedures. This method installs the pipeline while water flows through the construction work area. Golden Pass would operate the equipment from the banks of the waterbody. Spoil removed from the trench would be placed back into the pipe ditch after the pipe is installed, and excess spoils would be smoothed over the bottom surface. If the waterbody has no perceptible flow at the time of the crossing, Golden Pass would use upland construction techniques to cross the area (see figure 2.6-2).

### **Wetland Trenching Methods**

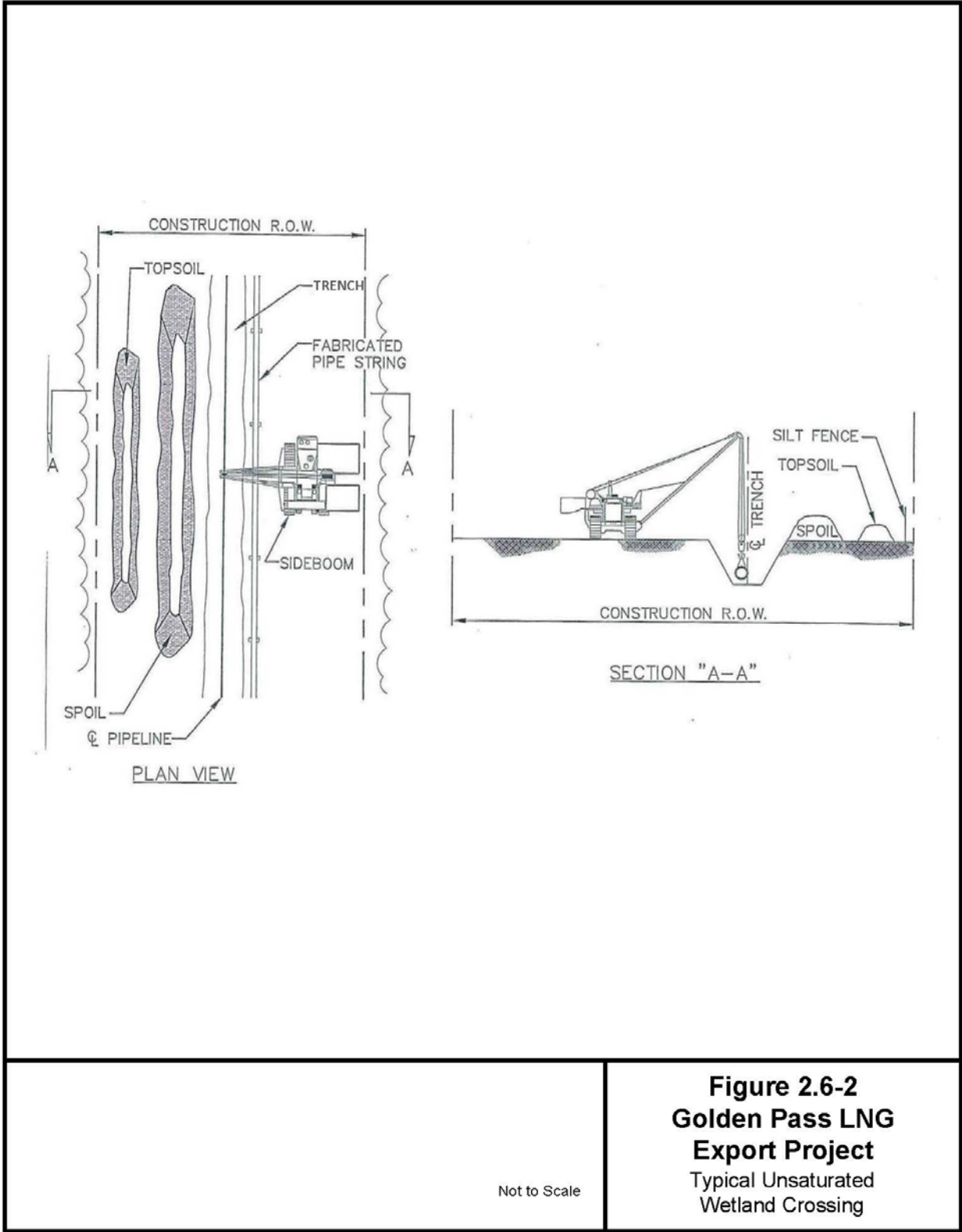
Golden Pass would construct the pipeline and associated facilities across wetlands in accordance with applicable federal and state permits and its Procedures. Site-specific crossing procedures to install the pipeline across wetlands would vary based on the level of soil stability and saturation encountered during construction. Construction procedures to cross unsaturated "dry" wetlands would be similar to those used in dry, upland areas, with topsoil being segregated from the subsoil (see figure 2.6-2). If standing water or saturated soil conditions are present, mats would be installed within workspaces to prevent rutting and mixing of the topsoil and subsoil (see figure 2.6-3). Golden Pass would limit construction equipment operating in wetland areas to that necessary to clear the construction right-of-way, dig the trench, fabricate and install the pipeline, backfill the trench, and restore the construction right-of-way.

Golden Pass would use a 75-foot-wide construction right-of-way through wetlands, where practical. Additionally, the construction right-of-way would overlap the existing Golden Pass Pipeline right-of-way, as the centerline of the new pipeline loop would be within 25 feet of the existing Golden Pass Pipeline, unless unforeseen constraints would adversely affect the stability of the existing pipeline.

In wetlands, Golden Pass would clear the entire construction right-of-way of vegetation by mechanical cutting or by hand, then grade it where necessary, to create a level and safe working surface for construction equipment. In accordance with FERC's Procedures, Golden Pass would minimize the length of time that topsoil is segregated and the trench is left open in wetlands.

For areas where existing natural gas infrastructure is immediately adjacent to wetlands, Golden Pass requested an alternative measure to allow ATWS to be within 50 feet of wetlands in order to collocate the Pipeline Expansion with the existing infrastructure (see section 4.3.2).

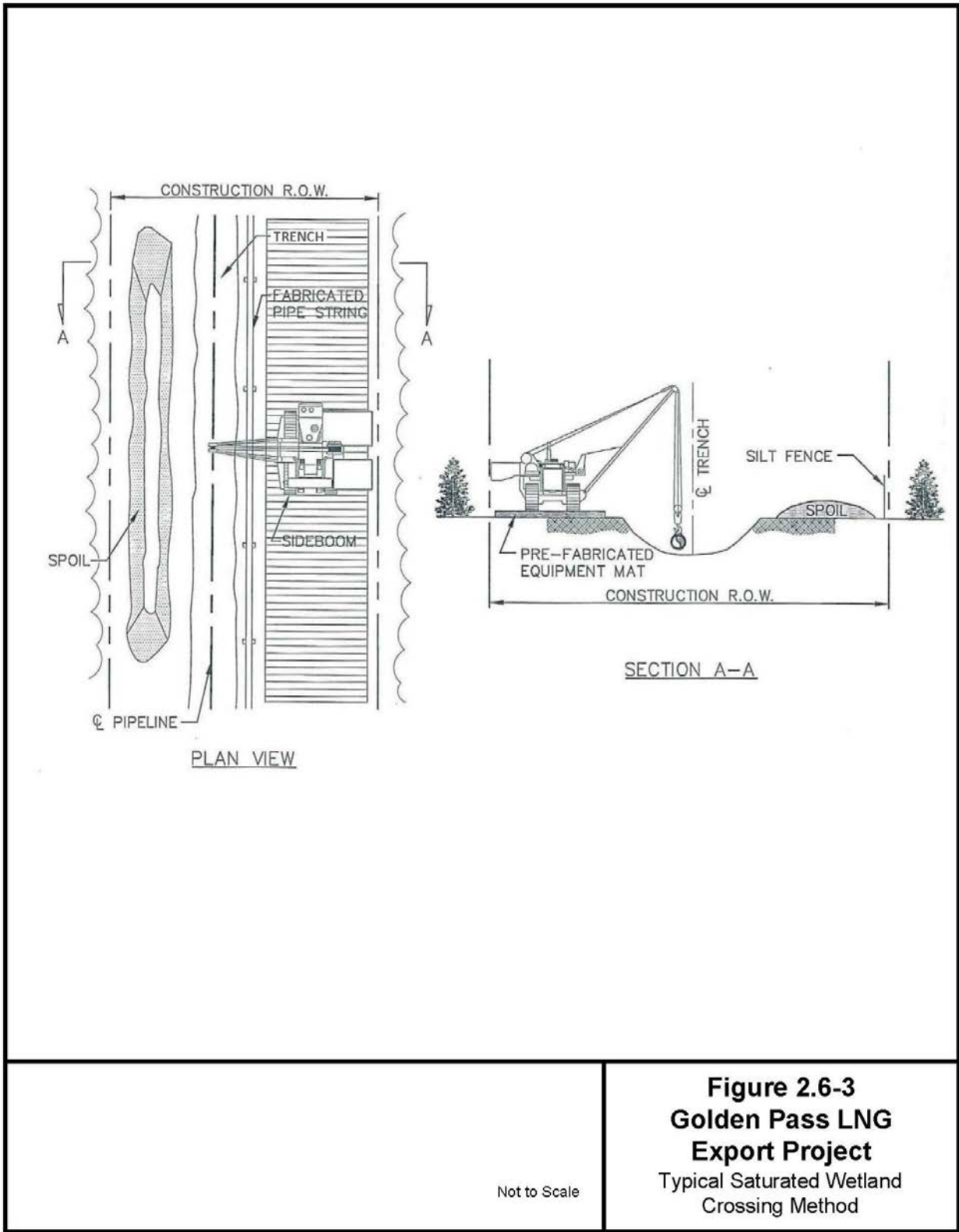
Where wetland soils are inundated, the pipeline may be installed using the push-pull technique. This technique involves stringing and welding the pipeline outside of the wetland and excavating the trench through the wetland using a backhoe supported by equipment mats. The water that seeps into the trench would be used to "float" the pipeline into place together with a winch and flotation devices that would be attached to the pipe. After the pipeline is floated into place, Golden Pass would remove the floats, and the pipeline would sink into place. After the pipeline sinks to the bottom of the trench, a trackhoe working on equipment mats would backfill the trench and complete any additional cleanup that is required.



Not to Scale

**Figure 2.6-2**  
**Golden Pass LNG**  
**Export Project**  
 Typical Unsaturated  
 Wetland Crossing





**Figure 2.6-3  
Golden Pass LNG  
Export Project**

Typical Saturated Wetland  
Crossing Method

Not to Scale

## **Horizontal Directional Drilling Method**

The pipeline route crosses a wetland in the vicinity of Starks Big Woods Road between MP 65 and MP 66 of the existing pipeline. Starks Big Woods Road, several other private roads, and the adjacent wetland would be crossed using the HDD method. The HDD crossing would begin at MP 65 and extend about 4,800 feet horizontally.

The HDD method is a trenchless crossing method used to avoid direct impacts on sensitive resources (such as wetlands) by conducting a deep bore beneath them. This method requires specialized equipment and personnel and has four general steps: (1) placement of guide wires over the anticipated path of the drill; (2) drilling a pilot hole on an arc-shaped path that typically extends between 30 and 50 feet beneath the sensitive resource; (3) enlarging the pilot hole with a series of reamers to accommodate the pipeline; and (4) pulling a pre-fabricated section of pipe through the hole. The HDD method involves an entry and exit pit on each side of the crossing, each of which would have an area of about 150 by 250 feet. The initial step of placing HDD guide wires over the path of the drill may require minor hand clearing of woody vegetation and/or branches. A pilot hole would be drilled under the wetlands and road. The head of the pilot drill string contains a pivoting head that can be controlled by an operator as the drill progresses. Typically, the pilot hole would be directed downward at an angle until the proper depth is achieved, then turned and directed horizontally for the required distance, and finally angled upward back to the surface. Throughout the process of drilling and enlarging the hole, a mud slurry (consisting of bentonite and water), would be pressurized and pumped through the drill stem to lubricate the drill bit, maintain the hole, and remove drill cuttings. Bentonite is a commercial name for a nontoxic mixture of non-toxic clays and rock particles consisting of about 85 percent montmorillonite clay, 10 percent quartz and feldspars, and 5 percent accessory materials such as calcite and gypsum. This slurry, referred to as drilling mud or drilling fluid, has the potential to be inadvertently released to the surface if fractures or fissures are encountered in the substrate during drilling.

The potential for an inadvertent release is generally greatest during drilling of the pilot hole, when the pressurized drilling mud follows the path of least resistance, and near the drill entry or exit pits, where the drilled hole is at its shallowest depths. For example, if the drill path becomes temporarily blocked or encounters areas such as large fractures or fissures that lead to the ground, an inadvertent release could occur. Golden Pass developed an acceptable *HDD Monitoring and Contingency Plan* to monitor for, contain, and clean up any inadvertent releases of drilling fluid during HDD operations. This plan is included in appendix C. Additional information on wetland construction, including the use of the HDD method, is presented in section 4.3.2.2.

### **2.6.3.2 Road, Railroad, and Foreign Pipeline Crossing**

The Pipeline Expansion route would cross paved and unpaved roads and foreign pipelines, but would not cross any railroads. Most of the unpaved roads would be crossed using the open-cut method, as would one private paved road at MP 0.1 of the Pipeline Expansion (near MP 63.5 of the existing pipeline). Golden Pass would construct the open-cut crossings in accordance with FERC's Plan and the requirements of all applicable crossing permits and approvals. Golden Pass would use traffic warning signs, detour signs, and other traffic control devices as required by federal, state, and local departments of transportation.

The Pipeline Expansion route would cross one paved public road (Starks Big Woods Road) and several nearby private unpaved agricultural roads. As noted in section 2.6.3.1, Golden Pass would use the HDD method from about MP 65 to 66 of the existing pipeline (Pipeline Expansion MP 1.6 to 2.6) to cross three of these roads and a wetland. Use of the HDD method would result in minimal or no disruption to traffic at road crossings.

Golden Pass would maintain a minimum clearance of 12 inches between the pipeline and the crossing of foreign pipelines in accordance with 49 CFR 192 and in compliance with pipeline crossing agreements negotiated with the foreign pipeline operators.

### **2.6.3.3 Residential Areas**

Based on aerial imagery interpretation and site surveys, no residences would be within 50 feet of either the construction right-of-way for the Pipeline Expansion or the aboveground facilities.

### **2.6.3.4 Agricultural Areas**

Agricultural areas along the pipeline route include active rice cultivation and silviculture (pine plantations) in Calcasieu Parish, Louisiana. Golden Pass would implement FERC's Plan in these areas to minimize impacts on current agricultural uses. Golden Pass would segregate the topsoil and use subsoil to backfill the pipeline trench. After backfilling, the segregated topsoil would then be spread across the graded pipeline right-of-way. Soil compaction would be treated as necessary in accordance with best management practices (BMPs) for erosion control and revegetation provided in FERC's Plan.

Following construction, all non-silviculture agricultural land used for temporary construction areas along the pipeline right-of-way would be allowed to revert to its prior use, and except for silviculture, agriculture would be permitted within the permanent easement in accordance with applicable easement agreements. Silviculture would not be allowed in the permanent right-of-way.

Golden Pass would conduct post-construction monitoring to evaluate restoration of the affected agricultural areas in accordance with FERC's Plan. For lands that are terraced and routinely flooded for rice production, Golden Pass would work with landowners to minimize effects on irrigation. Additional information on procedures that would be used in agricultural areas is presented in sections 4.2.2.2 and 4.8.1.3.

## **2.6.4 Aboveground Facilities Construction Procedures**

### **2.6.4.1 Compressor Stations**

Golden Pass would construct the aboveground facilities concurrently with pipeline installation, using special fabrication crews that would generally work separately from the pipeline construction crews.

Construction at each compressor station site would begin with improvement of access roads, followed by clearing, grubbing, grading, and compacting the site where necessary. Golden Pass would then initiate pile driving; excavate areas for foundations; pour the concrete foundations for buildings and skid-mounted equipment supports; and assemble the prefabricated segments of pipe, valves, fittings, and flanges at the site. The compressor units and other large equipment would be mounted on their respective foundations and the compressor enclosures erected around them. Golden Pass would install noise abatement equipment and emission control technology as needed to meet applicable federal, state, and local standards. Section 4.11.2 provides additional information on noise abatement and emission control technology. Electrical, septic, communication, utility, and cathodic protection systems would be installed as well.

Based on preliminary design information, Golden Pass anticipates that about 200 piles each would be required for the MP 33 and MP 66 Compressor Stations. The depth of the piles would range from 50 to 100 feet, depending on load and pile capacity requirements. Golden Pass anticipates that piles would be installed as drilled shafts or would use displacement piles to avoid use of a pile driving rig.

The number of piles required for the MP 1 Compressor Station is included in the total of 25,000 piles noted in section 2.6.1.2 for the Terminal Expansion. As described in that section, the depth of the piles would be from 100 to 150 feet, depending on the load and pile capacity requirements.

The MP 1 Compressor Station would be sited within the 100-year flood zone. Golden Pass would expand the existing storm protection levee to surround the compressor station. The MP 66 Compressor Station also would be sited within the 100-year flood zone. As a result, Golden Pass would install all equipment foundations a minimum of 2 feet above the 100-year flood zone elevation to prevent flooding of equipment. Although the MP 33 Compressor station would not be within the 100-year flood zone, it is in a low-lying area, and the working surface of the facility would also be a minimum of 2 feet above the 100-year flood zone elevation.

Golden Pass would hydrostatically test all facility piping, both above and below ground, before it is placed in service. Prior to discharge, Golden Pass would test the hydrostatic water in accordance with its LDEQ Hydrostatic Test Water Discharge Permit, which requires testing for oil and grease and pH, and monitoring of the discharge water for visible sheen. Golden Pass would discharge the test water through an energy-dissipating device to minimize erosion.

Golden Pass also would ensure that control and safety devices, such as the emergency shutdown system, relief valves, gas and fire detection facilities, and other protection and safety devices, are tested. Upon completion of compressor station construction, temporarily disturbed areas would be graded and graveled or revegetated with grass. All roads and parking areas within the boundaries of the compressor station would be graveled, or limestone would be spread on the surfaces. Finally, Golden Pass would fence all aboveground facilities for security.

#### **2.6.4.2 Interconnections and Metering Stations**

Construction work associated with the interconnections and metering station modifications and upgrades would occur primarily within the existing fenced and graveled areas. Only limited clearing and grading activities would be necessary, and site cleanup would involve replacing gravel on previously graveled areas and restoring surface contours—including the ATWS—to pre-construction conditions.

#### **2.6.5 Access Roads**

Golden Pass would design and construct the access roads to support the anticipated construction equipment and traffic. Reinforcements such as geogrids and geofabrics would be installed on the roads. For the access roads to the MP 33 and MP 66 Compressor Stations, the final grade of the roads would be raised sufficiently to prevent flooding, and culverts would be installed where appropriate to ensure that the roads do not impede water flow. In addition, the access road to the MP 66 Compressor Station would require widening to about 25 feet.

#### **2.6.6 Pipe Storage and Contractor Yard**

Preparation of the pipe storage and contractor yard would begin with marking and staking the yard boundaries and limits of the construction workspace, including access roads or entrances from public roads to the yards. After the marking is completed, the following activities would be conducted, as required by site conditions: installation of silt fencing, clearing and grubbing, filling and/or grading, and graveled where necessary. As noted above, Golden Pass would use only the graveled areas of the site that was used as a pipe storage and contractor yard during construction of the existing Golden Pass Pipeline.

## **2.7 OPERATION, MAINTENANCE, AND SAFETY PROCEDURES**

### **2.7.1 Terminal Expansion**

Golden Pass would operate its Terminal Expansion facilities consistent with (1) 49 CFR 193.2503 and 193.2605 which address federal requirements for LNG facilities (see table 1.5-1), including operation, emergency, and security procedures; (2) Sections 11.3.1 and 11.5.2 of the NFPA 59A; (3) 33 CFR 127; and (3) other applicable federal and state regulations. Golden Pass would update all current manuals as necessary to include the expanded terminal operations and submit amendments to the agencies prior to commissioning the Terminal Expansion facilities. Operating procedures would address normal operation as well as safe startup, shutdown, and emergency conditions. Golden Pass would train its operators to respond to potential hazards associated with the liquefaction process and the proper operations and maintenance of all equipment in accordance with the requirements of applicable regulatory entities such as the FERC, the Coast Guard, and the DOT.

LNG carriers would follow the currently approved transit to the Ship Slip and load LNG while discharging ballast water. Golden Pass anticipates that from 7 to 15 million gallons of sea water ballast would be discharged during cargo loading, depending on the size of the LNG carriers. The currently authorized size of LNG carriers ranges from 125,000 to 266,000 m<sup>3</sup>. Ballast water would be managed and discharged in accordance with the requirements of 33 CFR 151 (Vessels Carrying Oil, Noxious Liquid Substances, Garbage, Municipal or Commercial Waste and Ballast Water) and 46 CFR 162.060 (Ballast Water Management Systems), and would be inspected in accordance with the Coast Guard's Navigation and Vessel Inspection Circular 07-04.

During operation, Golden Pass would dispose of waste materials consistent with the requirements of federal, state, and local regulations. The specifics of waste disposal would be included in a *Waste Management Plan* that Golden Pass would file with the FERC prior to commissioning the Terminal Expansion.

Golden Pass would modify its maintenance regime, which includes corrective and preventative maintenance plans, to include the expanded terminal facilities. The plans include written procedures consistent with corporate policy and federal standards, including the DOT regulations in 18 CFR 127.401 and 49 CFR 193 (G).

Annual maintenance dredging would be conducted at the existing Ship Slip and the Supply Dock barge slip. Dredged materials from both facilities would be disposed of as required in Golden Pass' pending COE permit.

#### **2.7.1.1 Spill Containment System**

Regulations in 49 CFR 193, 33 CFR 127, and NFPA 59A govern the design and siting provisions for spill and leak control for LNG and related refrigerants. All new piping and equipment containing LNG or liquid refrigerant, as well as the facilities for unloading trucked refrigerant and loading LNG, would be provided with spill-collecting troughs and area curbing which would direct any potential spills to spill impoundments. These impoundments would be located as far as possible from personnel and operating equipment, and would be equipped with automatic temperature-activated vapor suppression, high-expansion foam systems. In addition, the spill containment troughs and impoundments would include instrumentation to provide early detection of liquid releases.

Additional information on spill containment system operation, maintenance, and safety information is presented in section 4.12.

### **2.7.1.2 Hazard and Fire Detection and Control Systems**

The existing terminal system provides alarm signaling and notification when a hazardous condition is present. Golden Pass would expand the hazard and fire detection system for the existing terminal to include the expanded terminal and hardwire it to the main alarm control system. The system includes flame detectors, natural gas detectors, low and high temperature detectors, and smoke detectors. The hazard detection system provides for the following:

- early detection of released gases, flammable gas, liquids, and fires;
- identification of the specific location of a release or fire;
- initiation of automatic equipment shutdowns; and
- automatic initiation of fire control systems.

Additional details of the expanded system are presented in section 4.12.

### **2.7.1.3 Quenching and Fire Suppression Systems**

Golden Pass would employ a variety of fire suppression agents for fire protection within the expanded terminal. The type of agent used in a specific situation would depend on the characteristics of a particular event and the relative effectiveness of the various agents on that particular type of fire relative to either a specific unit of the plant design or operation. The types of fire suppression agents to be used include the following:

- a looped, underground firewater distribution piping system serving fire hydrants, fire monitors, and hose reels;
- a fixed, high-expansion foam system;
- fixed dry chemical (and/or clean agent) systems;
- portable and wheeled fire extinguishers using dry chemical and CO<sub>2</sub>; and
- fire protection in buildings, generally consisting of smoke detectors, ultraviolet infrared flame detectors, and portable fire extinguishers.

The existing terminal has a firewater supply and looped underground distribution system to assist in controlling or extinguishing fires, cooling structures and equipment exposed to thermal radiation, and dispersing flammable vapors. Access to firewater is provided by hydrants, fire monitors, and hose reels located throughout the facility; and high-expansion foam systems are located at the LNG spill containment sumps.

For reliability, the existing terminal has two sources of firewater: the primary firewater supply is freshwater from an onsite storage tank; and the secondary source of firewater is saltwater, in the event that the stored freshwater supply is exhausted. Freshwater is obtained from the municipal water system and stored in an onsite tank that is sized to provide 2 hours of firewater supply at the design maximum firewater supply rate of 4,000 gpm. The storage tank is designed in accordance with NFPA 22 and American Petroleum Institute (API) 620. Freshwater is transferred to the distribution system by means of an electric-driven pump, and an electric-driven jockey pump maintains pressure on the underground firewater distribution system. The freshwater firewater pump automatically starts when there is a pressure decrease in the freshwater header system. Golden Pass would install a new diesel-driven, seawater firewater pump to replace the existing seawater firewater pump; the new firewater pump would serve as a backup for the freshwater supply system. Section 2.2.1.7 provides information on the seawater intake system for firewater.

Golden Pass would expand and modify these existing systems to accommodate facility changes associated with the Terminal Expansion.

#### **2.7.1.4 Emergency Shutdown System**

The existing terminal has an emergency shutdown system to allow for safe termination of operations in the event of an incident. Initiation of the shutdown sequence is either manual, by means of hand-operated stations located throughout the facility, or automatic, based on information originating from the various hazard detectors positioned at critical locations in the facility. The emergency shutdown system allows for shutdown of the entire facility or individual sections, depending on the particular incident. Alarms are provided in the control room to notify operating personnel, should a potentially hazardous condition be detected by the field instrumentation.

Golden Pass would modify the emergency shutdown system to extend these emergency shutdown measures to the expanded terminal. Additional information on the shutdown system of the expanded terminal is presented in section 4.12.

#### **2.7.1.5 Emergency Response Plan**

The existing Golden Pass Import Terminal has an *Emergency Response Plan* (ERP) that conforms to the requirements of 49 CFR 193.2509, and the July 6, 2005 Order No. 112 FERC ¶ 61,041, as amended. The key elements for the ERP are listed below:

- identification and assessment of the hazard;
- prompt notification and mobilization of emergency response resources;
- development and maintenance of appropriate emergency response capabilities; and
- ongoing training programs.

The ERP and operating procedures are used by terminal personnel, as well as for developing emergency procedures with third-party emergency responders, and in continuing liaison with appropriate agencies, such as local fire departments, police departments, and medical facilities. Prior to commissioning the Terminal Expansion, Golden Pass would update the existing ERP to incorporate revisions required due to operation of the Terminal Expansion facilities. The updated ERP would include any additional or specialized training or fire response requirements that may be required or recommended to support the addition of new products and components. As part of the update, Golden Pass would work with local mutual aid organizations and emergency response subject matter experts to identify any additional coordination, response equipment, or training that may be anticipated for the additional facilities, as well as any cost-sharing opportunities. The revised ERP would be readily accessible on site, and a copy of the revised plan would be distributed to all appropriate parties.

#### **2.7.2 Pipeline Expansion**

Golden Pass would operate and maintain the Pipeline Expansion in accordance with the DOT regulations in 49 CFR 192, other applicable federal and state regulations, and industry standard procedures designed to ensure the integrity of the pipeline and minimize the potential for pipe failure. The existing Golden Pass Pipeline Integrity Management System would be modified for the Pipeline Expansion facilities in accordance with DOT requirements. Golden Pass would inspect the pipeline as part of scheduled maintenance for the existing Golden Pass Pipeline, which is conducted in accordance with 49 CFR 192.

Golden Pass would install pipeline identification markers at line-of-sight intervals and other critical points (e.g., road crossings). The markers would identify Golden Pass as the operator and provide telephone

numbers for emergencies and inquiries. Golden Pass is also a member of the “One Call” and related pre-excavation notification organizations.

### **2.7.2.1 Corrosion Protection and Detection System**

Golden Pass would install a cathodic protection system to prevent or minimize corrosion of the buried pipeline and aboveground facilities. The effectiveness of the cathodic protection system would be monitored during regularly scheduled cathodic protection surveys in accordance with federal standards and regulations. Cathodic protection surveys usually require walking the pipeline right-of-way with monitoring instruments.

### **2.7.2.2 Pipeline Emergency Response Procedures**

The DOT regulations at 49 CFR 192 (Transportation of Natural and Other Gas by Pipeline: Minimum Federal Safety Standards) are intended to ensure adequate protection for the public and prevent natural gas pipeline facility accidents and failures. Part 192 specifies material selection and qualification; minimum design requirements; and protection from internal, external, and atmospheric corrosion. Part 192 also prescribes the minimum standards for operating and maintaining pipeline facilities, including the requirement to establish a written plan governing these activities. Under Part 192.615, each pipeline operator must also establish an emergency plan that includes procedures to minimize the hazards in a natural gas pipeline emergency. Key elements of the plan include the following:

- receiving, identifying, and classifying emergency events, gas leakage, fires, explosions, and natural disasters;
- establishing and maintaining communications with local fire, police, and public officials in coordinating emergency response;
- making personnel, equipment, tools, and materials available at the scene of an emergency;
- protecting people first and then property, and ensuring safety from actual or potential hazards; and
- emergency shutdown of the system and safe restoration of service.

Part 192 also requires that each operator establish and maintain a liaison with appropriate fire, police, regulatory, and public officials to learn the resources and responsibilities of each organization that may respond to a natural gas pipeline emergency, and to coordinate mutual assistance. This includes establishing a continuing education program to enable customers, the public, government officials, and those engaged in excavation activities to recognize a gas pipeline emergency and report it to appropriate public officials.

Golden Pass has existing emergency response procedures in place that meet these requirements and would expand the program to incorporate procedures specific to the Pipeline Expansion.

## **2.8 FUTURE PLANS AND ABANDONMENT**

Golden Pass stated that it is considering the future use of LNG carriers that are smaller than the 125,000 m<sup>3</sup> carriers. Golden Pass also stated that it is considering the use of LNG “bunkering” barges if a market for that service develops. That future use would consist of barges transporting about 3,000 to 12,000 m<sup>3</sup> of LNG from the expanded terminal to marine vessels that use LNG for fuel. However, Golden Pass stated that, with either or both of these options, the total number of transits of all LNG vessels associated with the Project is not expected to exceed the currently analyzed number of transits per year.



The facilities required for use of smaller LNG carriers or LNG bunkering barges, such as modified LNG transfer arms and additional permanent marine dolphins, are included in the Project (see section 2.2.1.6). Consequently, if all permits and authorizations are obtained for those potential future uses, the facilities required for their use would be in place, and no additional construction would be required. Golden Pass determined that constructing those facilities as a part of the Project would avoid future conflicts with LNG loading operations that would occur if the facilities were constructed when the Project is operating.

Golden Pass is not currently seeking authorization for the use of smaller LNG carriers or bunkering barges. If Golden Pass decides to go forward with either or both of these options, it would need to consult with the Coast Guard regarding the LNG marine vessel transits and obtain all permits, certifications, and authorizations required at that time.

Golden Pass does not have any foreseeable plans to abandon the existing terminal or the associated pipeline facilities. If the Project facilities are abandoned in the future, Golden Pass would need to comply with the appropriate federal, state, and local regulations in effect at that time (including the FERC's abandonment regulations).

### **3.0 ALTERNATIVES**

To adhere to the CEQ regulations for complying with NEPA (at 40 CFR 1502.14), the EIS must evaluate reasonable alternatives. This EIS compares the environmental impacts of the proposed action against a range of alternatives.

Each of the cooperating agencies with obligations under NEPA can use this alternatives analysis as part of their decision-making process. Individual agencies would ensure consistency with their own administrative procedures prior to accepting the recommendations in this EIS.

In accordance with NEPA and Commission policy, we evaluated alternatives to the Project to determine whether any would be reasonable and have significant environmental advantages compared to the proposed action. The alternatives analyzed consisted of the No-Action Alternative, system alternatives for the Terminal Expansion and the Pipeline Expansion, alternative Terminal Expansion locations, alternative Supply Dock locations, alternative Terminal Expansion configurations and power sources, alternative pipeline routes, alternative Pipeline Expansion aboveground facility sites, alternative sites for pipe storage and contractor yards, and alternative compressor station design.

The evaluation criteria for considering alternatives were:

- ability to reasonably meet the Project primary objective of transporting and liquefying domestic natural gas into LNG for export, and delivering competitively priced LNG to foreign markets;
- technical and economic feasibility and practicality; and
- significant environmental advantage over the proposed Project.

Golden Pass participated in our pre-filing process during the preliminary design stage for the Project (see section 1.3). This process emphasized identification of potential stakeholder issues, as well as identification and evaluation of alternatives that could avoid or minimize impacts. We analyzed each alternative based on scoping comments and guidance received from federal, state, and local regulatory agencies. Additional input used during the analysis of alternatives included information provided by Golden Pass field surveys, aerial photographs, U.S. Geological Survey (USGS) topographic maps, National Wetlands Inventory (NWI) maps, agency consultations, and other publicly available information. Identical data sources were used when comparing the alternative to the Project (e.g., NWI maps were used for analyses of both the alternative and the Project).

It is important to recognize that not all conceivable alternatives are technically and economically feasible and practical. Some alternatives may be impracticable because they are unavailable or incapable of being implemented after taking into consideration costs, existing technologies, and the overall Project purpose. We do not design LNG terminal and natural gas pipeline projects. Rather, companies propose and design projects in response to market conditions. In turn, we analyze these proposals and identify and disclose a reasonable range of alternatives. In conducting this analysis, it is important to recognize the environmental advantages and disadvantages of the proposed actions in order to focus the analysis on reasonable alternatives that may reduce impacts and offer a significant environmental advantage. A detailed discussion of the environmental consequences of the Project (both adverse and beneficial) is included in section 4.

#### **3.1 NO-ACTION ALTERNATIVE**

If the FERC denies the Golden Pass application (the No-Action Alternative), the objectives of the Project would not be met and the resource impacts (including short- and long-term and permanent impacts) disclosed in this EIS would not occur. However, selection of the No-Action Alternative could result in the

use or expansion of other existing or proposed LNG facilities and associated interstate natural gas pipeline systems, or in the construction of new infrastructure to meet the objectives of the Golden Pass Export Project (i.e., to export LNG to global markets). In section 3.2, we examine natural gas and LNG system alternatives. Any expansion of existing systems or construction of new facilities would result in specific environmental impacts that could be less than, similar to, or greater than those associated with the Golden Pass Project.

The No-Action Alternative also would not provide the potential economic benefits associated with the Project, including increased jobs, secondary spending, and tax revenues, as discussed in sections 4.9.1 and 4.9.2.

Commenters have suggested generally that LNG export projects could be replaced by renewable energy resources alternatives. Renewable energy resources include, but are not limited to, wind power, solar power, tidal power, and hydropower. All of these alternatives represent alternative means of producing electrical power. Because the Project's primary purpose is to prepare natural gas for export to foreign markets, development or use of renewable energy technology would not be a reasonable alternative to the proposed action.

## **3.2 SYSTEM ALTERNATIVES**

System alternatives would make use of other existing, modified, or proposed LNG facilities and/or pipeline systems to meet the stated objectives of the proposed project. A system alternative would make it unnecessary to construct all or part of a proposed project; however, some modifications or additions to another existing system may be necessary to meet the project's purpose and need. Such modifications or additions would result in environmental impacts that could be less than, similar to, or greater than those associated with construction of a proposed project. The purpose of identifying and evaluating system alternatives is to determine whether potential environmental impacts associated with construction and operation of proposed facilities could be avoided or reduced while still meeting the basic objectives of the proposed project.

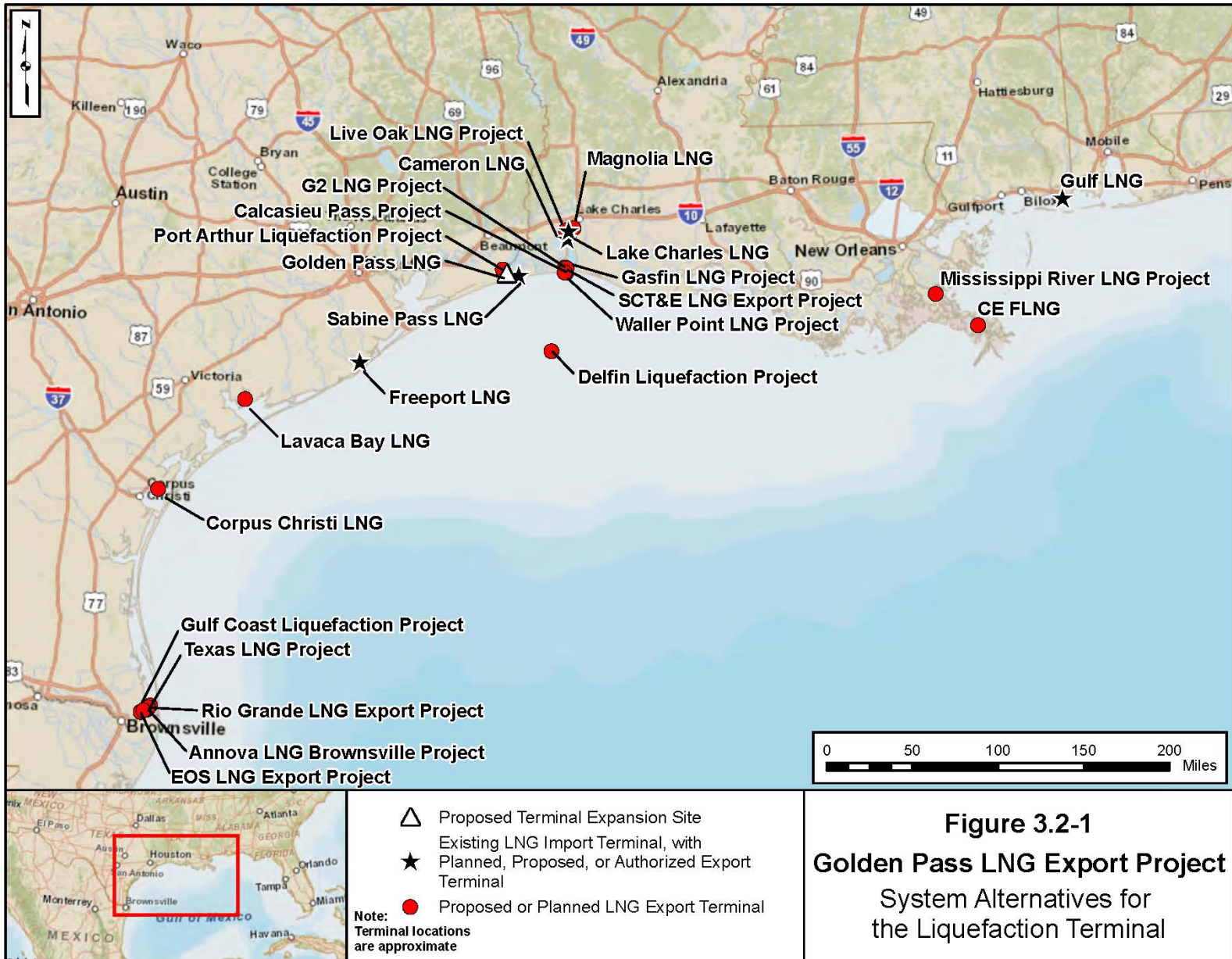
We reviewed system alternatives to evaluate the ability of existing, modified, or proposed facilities to meet the stated objectives of the Golden Pass LNG Export Project. Our analysis of the system alternatives is presented in section 3.2.1 for the Terminal Expansion and in section 3.2.2 for the Pipeline Expansion.

### **3.2.1 Liquefaction Terminal System Alternatives**

For a system alternative to be viable, it must meet the purpose and need of the Terminal Expansion, be technically and economically feasible, and offer a significant environmental advantage over the Terminal Expansion. The system alternatives considered in this analysis are depicted in figure 3.2-1. We considered each of the planned, proposed, or authorized projects<sup>16</sup> as potential system alternatives, either individually (see sections 3.2.1.1 through 3.2.1.3) or in combination (see section 3.2.1.4).

---

<sup>16</sup> "Proposed projects" are projects for which the proponent has submitted a formal application with the FERC or, for deepwater port projects, with the U.S. Department of Transportation's Marine Administration (MARAD) and the Coast Guard; "planned projects" are in pre-filing or have been announced but have not been proposed.



**Figure 3.2-1**  
**Golden Pass LNG Export Project**  
 System Alternatives for  
 the Liquefaction Terminal

### **3.2.1.1 Existing LNG Import Terminals with Planned, Proposed, or Authorized Liquefaction Projects**

Five existing LNG import terminals are located in the southeastern United States along the Gulf of Mexico, in addition to the existing Golden Pass Import Terminal:

- Cameron LNG Terminal (Cameron LNG, LLC [Cameron LNG]);
- Freeport LNG Terminal (Freeport LNG Development, LP [Freeport LNG]);
- Gulf LNG Terminal (Gulf LNG Energy, LLC [Gulf LNG]);
- Sabine Pass Terminal (Cheniere Energy Partners, LP [Cheniere Energy]); and
- Lake Charles LNG Terminal (Trunkline LNG Company, LLC [Trunkline LNG]).

Modifications to three of these terminals, the Sabine Pass Terminal, the Cameron LNG Terminal, and the Freeport LNG Terminal, are currently underway to allow for new or additional LNG liquefaction and export. The other import terminals are in the regulatory review and permitting process for adding liquefaction and export capabilities. Each of these facilities was considered as a system alternative to the Project.

#### **Cameron LNG Terminal**

The existing Cameron LNG Terminal is in Cameron Parish, Louisiana on the west side of the Calcasieu Ship Channel, about 40 miles east of the Golden Pass Import Terminal. On June 19, 2014, the Commission authorized Cameron LNG to site, construct, and operate the Cameron Liquefaction Project, including construction and operation of the expanded associated pipeline system (Docket Nos. CP13-25-000 and CP13-27-000). Construction began in October 2014, with LNG liquefaction anticipated to begin in 2018 and full operation expected to begin in 2019.

The Cameron Liquefaction Project facilities are being constructed adjacent to the existing Cameron LNG Terminal and will use much of the existing terminal's infrastructure, including LNG storage tanks and the LNG carrier berthing facilities. The Cameron Liquefaction Project consists of three liquefaction trains, 21 miles of 42-inch-diameter pipeline, one compressor station, and ancillary facilities in Cameron, Calcasieu, and Beauregard Parishes, Louisiana. The project is being constructed on about 502 acres, including 70 acres within the existing terminal boundary, and will be capable of exporting up to 15 mtpy of LNG.<sup>17</sup>

On September 28, 2015, Cameron LNG filed an application with FERC to construct the Cameron LNG Trains 4 & 5 Expansion Project (CP15-560-000). Cameron LNG would expand the Cameron Liquefaction Project facilities to include two additional liquefaction trains, each with a capacity of about 5 mtpy, and an additional LNG storage tank with a capacity of 160,000 m<sup>3</sup>. Cameron LNG would begin construction of this expansion in June 2016, initiate production of the additional trains in the second quarter of 2019, and begin full production in the fourth quarter of 2019. If this expansion is approved, the total export capacity of the Cameron LNG Terminal would be 24.9 mtpy of LNG. The FERC issued an Environmental Assessment for this project on February 12, 2016.

The entire capacity of the original Cameron Liquefaction Project is contracted. The planned Cameron LNG Trains 4 & 5 Expansion Project facilities would need at least one more train to have sufficient capacity to meet the proposed output of the Golden Pass Project. The available land in the vicinity

---

<sup>17</sup> On April 9, 2015, Cameron LNG was granted authorization by the DOE to export an additional 3.0 mtpy of LNG over 20 years to Free Trade Agreement countries. The initial authorization for the Cameron Liquefaction Project was 12 mtpy.

of the Cameron Liquefaction Project is essentially all wetlands and open water; construction of the additional trains and associated facilities needed to match the proposed output of the Terminal Expansion would likely result in environmental impacts similar to or greater than those of the Terminal Expansion. In addition, Cameron LNG has not requested authorization for increased capacity beyond that of Trains 1 through 5, and the permitting and authorization processes necessary for constructing and operating the additional facilities would substantially delay meeting the anticipated timeline for the Terminal Expansion. Therefore, the expansion of the Cameron LNG Terminal was not considered to provide a significant environmental advantage or be a reasonable system alternative to the Terminal Expansion and was removed from further consideration.

### **Freeport LNG Terminal**

The existing Freeport LNG Terminal is on Quintana Island in Brazoria County, Texas, about 102 miles southwest of the Golden Pass Import Terminal. The Freeport LNG import terminal started operations in 2008 and includes two 160,000 m<sup>3</sup> LNG storage tanks and a single berth capable of handling LNG carriers in excess of 200,000 m<sup>3</sup>. It has a peak sendout capability of about 1.5 bcf/d of natural gas.

On July 30, 2014, the Commission authorized the Freeport LNG Liquefaction Project (Docket No. CP12-509-000), allowing Freeport LNG Expansion, LP and FLNG Liquefaction, LLC (collectively, FLEX) to site, construct, and operate facilities to liquefy and export domestic natural gas from the existing Freeport LNG Terminal (Docket No. CP03-75-000). Construction of the liquefaction facilities began in November 2014. FLEX anticipates startup for the first liquefaction train to occur in 2018 and full service to begin in 2019.

The new facilities consist of a liquefaction plant with three trains, each with a capacity of 4.4 mtpy, pre-treatment plant facilities that interconnect with several pipelines, and facilities to allow bi-directional flow of gas through the existing Freeport Pipeline. The Freeport LNG Liquefaction Project will require about 86 acres for the three trains and provide a total liquefaction capacity of 13.2 mtpy of LNG.

The full capacity of the three trains of the currently authorized Freeport LNG Terminal expansion is contracted. Use of the Freeport LNG Terminal as a system alternative to meet the objectives of the Project would require that FLEX construct and operate four additional liquefaction trains and associated facilities, similar to those of the Terminal Expansion,. On June 3, 2015, FLEX entered into the FERC's pre-filing process for the proposed Freeport LNG Liquefaction Expansion Project (PF15-25-000). The project would consist of construction of an additional liquefaction train (Train 4) with a capacity of about 5.1 mtpy and supporting utility and auxiliary facilities and infrastructure. If approved, FLEX anticipates the project would enter service in 2021.

The FLEX property on Quintana Island is of finite size (the pre-treatment plant is being built off-site). Construction of three additional liquefaction trains at the Freeport Terminal would likely require building at a location that was deemed unsuitable for the Freeport Terminal expansion due to operational noise impacts on the surrounding Quintana Island residents. Other locations at the Freeport Terminal would likely result in environmental impacts similar to or greater than those of the Terminal Expansion.

Furthermore, FLEX has not requested authorization for additional increased capacity and the necessary permits and approvals for additional facilities. The time required to obtain FERC authorization and additional permits and to construct the additional facilities would substantially delay the availability of the amount of capacity proposed for the Terminal Expansion. Therefore, expansion of the Freeport Terminal was not considered to provide a significant environmental advantage or be a reasonable system alternative to the Terminal Expansion and was removed from further consideration.

## **Gulf LNG Terminal**

The existing Gulf LNG import terminal is on a 33-acre site in Pascagoula, Mississippi, about 330 miles east of the Golden Pass Import Terminal. It started operations in October 2011 and has a sendout capacity of 1.3 bcf/d of natural gas. The import terminal includes two 160,000 m<sup>3</sup> LNG storage tanks and a single LNG carrier berth designed to receive LNG carriers with capacities of up to 250,000 m<sup>3</sup>. On June 19, 2015, Gulf LNG filed its application with the FERC for the Gulf LNG Liquefaction Project (Docket No. CP15-521-000) to construct facilities to liquefy natural gas for export.

If approved, Gulf LNG would construct its export project adjacent to the existing terminal, using the existing LNG storage tanks and LNG carrier berthing facilities. Key components would include two liquefaction trains and related facilities and a supply dock. The Gulf LNG Liquefaction Project would export up to 11 mtpy of LNG.

The Gulf LNG Terminal would need to add a third liquefaction train to meet the purpose and need of the Golden Pass Project. However, the proposed Gulf LNG Liquefaction Project encompasses the majority of land suitable for construction in the vicinity of the existing Gulf LNG import facility; the remaining surrounding land primarily consists of coastal wetlands and the COE's Bayou Casotte Dredged Material Management Site, which has no additional area available for use by Gulf LNG. It is unlikely that a sufficient amount of land exists near the existing Gulf LNG terminal to construct additional trains. If the area were available, the resultant impacts of constructing the required additional facilities in coastal wetlands would be similar to or greater than those of the Terminal Expansion. Therefore, the proposed expansion of the Gulf LNG Terminal was not considered to provide a significant environmental advantage or be a reasonable system alternative to the proposed Terminal Expansion and was removed from further consideration.

## **Sabine Pass LNG Terminal**

The existing Sabine Pass LNG Terminal is in Cameron Parish, Louisiana, on the eastern shore of the Sabine Pass Channel, about 2 miles east of the Golden Pass Import Terminal. It is located on an 853-acre site and includes five LNG storage tanks with a total storage capacity of 4.79 million cubic meters and two LNG carrier berths. The facility has a sendout capacity of 4 bcf/d of natural gas.

On April 16, 2012, the FERC authorized Sabine Pass LNG to receive, process, and export 16 mtpy of natural gas as part of its liquefaction project (Docket No. CP11-72-000). The Sabine Pass Liquefaction Project is approved for up to four liquefaction trains, each with an average liquefaction capacity of about 4 mtpy. The liquefaction and export project is under construction and will involve permanent use of about 191 acres as well as temporary disturbance of about 97 acres within the existing Sabine Pass LNG Terminal site.

On August 2, 2013, the FERC authorized Sabine Pass LNG to accelerate construction of Trains 3 and 4 of the Sabine Pass Liquefaction Project to coincide with construction of Trains 1 and 2 (Docket No. CP13-2-000). On February 20, 2014, the FERC authorized Sabine Pass to increase the approved capacity of the Sabine Pass Liquefaction Project from about 16 to about 20 mtpy (Docket No. CP14-12-000). Sabine Pass LNG anticipates that Trains 1 and 2 will be placed into service in 2016 and Trains 3 and 4 will be placed in service in 2017.

On April 6, 2015, the FERC approved the Sabine Pass Liquefaction Expansion Project, which authorized Sabine Pass LNG to construct and operate two additional trains (Trains 5 and 6) at the Sabine Pass LNG Terminal (Docket No. CP13-552-000). The additional trains will add 9 mtpy of capacity to the 20 mtpy already authorized for the Sabine Pass Liquefaction Project. Sabine Pass LNG anticipates that

Train 5 will be placed into service in 2019 and Train 6 will be placed into service at a later date when commercially feasible.

Sabine Pass LNG has reported that it has contracts for the initial capacity of LNG from Trains 1 through 4 (16 mtpy) and 3.75 mtpy of LNG from the 9-mtpy capacity of Trains 5 and 6 (Cheniere Energy 2014). Although some liquefaction capacity (9.25 mtpy) may remain unsubscribed, the unsubscribed capacity is insufficient to meet the delivery requirements of the Golden Pass Project. Furthermore, because this capacity was approved by the DOE in its public interest determination process, we will not assume that any such capacity is “excess” and would remain unutilized throughout the lifetime of the Sabine Pass Liquefaction and Expansion Projects, and therefore would be available to meet the purpose of the Golden Pass Project.

To meet the objectives of the Golden Pass Project, Sabine Pass LNG would need to construct and operate at least three additional liquefaction trains and associated facilities. This would likely result in similar environmental impacts as those of the Terminal Expansion. However, there is no land available for additional expansion of the Sabine Pass LNG Terminal and Sabine Pass has not proposed construction and operation of additional liquefaction trains. The permitting and authorization processes for constructing these additional facilities and the time required for construction would substantially delay meeting the proposed timeline for the Terminal Expansion. Therefore, the expansion of the Sabine Pass Liquefaction Terminal was not considered to provide a significant environmental advantage or be a reasonable system alternative to the Terminal Expansion and was removed from further consideration.

### **Lake Charles LNG Terminal**

The existing Lake Charles import terminal is in Lake Charles, Louisiana; it started operations in 1977. The import terminal is situated on about 125 acres, about 46 miles northeast of the Terminal Expansion site, with a peak sendout capacity of 2.1 bcfd of natural gas. Two LNG carrier berths provide loading and unloading capacity.

On December 17, 2015, the FERC issued an order authorizing Trunkline LNG to site, construct, own, and operate the Lake Charles Liquefaction Project facilities (Docket No. CP14-120-000) and to construct, own, and operate minor facility modifications at the Trunkline LNG Terminal to facilitate the storage and subsequent export of the LNG.

Trunkline LNG will construct the Lake Charles Liquefaction Project on a 400-acre parcel, about 0.5 mile west of the existing Lake Charles LNG Terminal. The facility will include three liquefaction trains, each capable of producing 5 mtpy, for a total output capacity of 15 mtpy. The first liquefaction train of Lake Charles Liquefaction Project is anticipated to be placed into service in July 2019. Full service is anticipated to begin in about July 2020.

The export capacity of the Lake Charles Liquefaction Project is fully contracted to one customer, BG LNG. Consequently, Trunkline LNG would need to construct four additional liquefaction trains and associated facilities to achieve the objectives of the Golden Pass Project while also meeting its contracted export capacity. The environmental impacts of the additional facilities would likely be similar to those of the Terminal Expansion. Therefore, additions to Trunkline LNG’s proposed project would not provide a significant environmental advantage to the Terminal Expansion. In addition, Trunkline LNG has not requested authorization for the increased capacity. The time required to obtain receipt of the permits and approvals for the additional facilities required to meet the objectives of the Golden Pass Project would substantially delay meeting the proposed timeline for the Terminal Expansion. Therefore, the Lake Charles LNG Terminal was not considered to provide a significant environmental advantage or be a reasonable system alternative to the Terminal Expansion and was removed from further consideration.



### 3.2.1.2 Authorized, Proposed, and Planned Stand-alone LNG Export Terminals<sup>18</sup>

In addition to the existing LNG import facilities described above, we considered the following planned, proposed, and authorized stand-alone liquefaction projects along the Gulf Coast as potential system alternatives:

- Corpus Christi Liquefaction Project, proposed by Corpus Christi Liquefaction, LLC and Cheniere Corpus Christi Pipeline, LP (collectively referred to as Cheniere);
- Lavaca Bay LNG Project, proposed by Excelerate Liquefaction Solutions, LLC (Excelerate);
- Magnolia LNG Project, proposed by Magnolia LNG (Magnolia);
- CE FLNG Project, planned by CE FLNG, LLC and CE Pipeline, LLC (collectively referred to as CE FLNG);
- Calcasieu Pass Project, planned by Venture Global Calcasieu Pass, LLC (Venture Global);
- SCT&E LNG Export Project, planned by SCT&E LNG, LLC (SCT&E);
- Mississippi River LNG Project, planned by Louisiana LNG Energy, LLC (Louisiana LNG);
- Eos LNG Export Project, planned by Eos LNG, LLC (Eos);
- Texas LNG Project, planned by Texas LNG, LLC (Texas LNG);
- Delfin Liquefaction Project, planned by Delfin LNG, LLC (Delfin);
- Port Arthur Liquefaction Project, planned by Port Arthur LNG (Port Arthur);
- G2 LNG Project, planned by G2 LNG, LLC (G2 LNG);
- Annova LNG Brownsville Project, planned by Annova LNG Common Infrastructure, LLC (Annova LNG);
- Rio Grande LNG Export Project, planned by Rio Grande LNG, LLC (Rio Grande LNG), a subsidiary of NextDecade, LLC (NextDecade);
- Gasfin LNG Project, planned by Gasfin Development USA, LLC;
- Gulf Coast Liquefaction Terminal, planned by Gulf Coast LNG Exports, LLC (Gulf Coast);
- Live Oak LNG, planned by Live Oak LNG LLC, a subsidiary of Parallax Energy LLC; and
- Waller Point LNG Project, planned by Waller Point LNG (Waller Point).

#### **Corpus Christi Liquefaction Project**

On December 30, 2014, the FERC issued an Order authorizing the Corpus Christi Liquefaction Project. Corpus Christi initiated construction in February 2015, with service anticipated to begin in late 2018. The project (Docket No. CP12-507-000) is in San Patricio County, Texas, on the northeast side of Corpus Christi Bay at the previously authorized site for the Corpus Christi LNG import terminal. The import terminal was never constructed due to market conditions (see Docket No. CP04-37-000). The export terminal is about 241 miles southwest of the Golden Pass Import Terminal and will include three liquefaction trains, each with an average liquefaction capacity of about 4.5 mtpy, for a total capacity of 13.5 mtpy; three 160,000 m<sup>3</sup> LNG storage tanks; and two LNG carrier docks. The project also includes a 23-mile-long, 48-inch-diameter pipeline that would connect the LNG terminal with five interstate and intrastate

---

<sup>18</sup> “Stand-alone” liquefaction projects are not associated with existing LNG import projects and are typically greenfield projects (i.e., they are constructed in primarily undisturbed areas).

natural gas transmission pipelines in south Texas. This liquefaction and export project would affect about 1,000 acres of land during construction.

On June 9, 2015, the FERC initiated the pre-filing process to review the Corpus Christi LNG Stage 3 Project, which would add facilities to its authorized liquefaction terminal (PF15-26-000). The project would entail constructing two additional liquefaction trains, each with an average liquefaction capacity of about 4.5 mtpy, an additional 160,000 m<sup>3</sup> LNG storage tank, and a 22-mile-long 42-inch-diameter pipeline that would be constructed adjacent and parallel to the Corpus Christi pipeline currently under construction. The targeted in-service date for this project would be in 2021.

Cheniere reports that the Corpus Christi LNG Project has contracted for delivery of 8.42 mtpy of the original 13.5-mtpy capacity of LNG. Even with the additional 9.0 mtpy that would result from constructing the Stage 3 Project, the Corpus Christi LNG Project would not be able to provide the volume of LNG required to meet the objectives of the Golden Pass Project without constructing and operating at least one additional liquefaction trains and associated facilities. The environmental impacts of the additional facilities would likely be similar to those of the Terminal Expansion and would not offer a significant environmental advantage over the Golden Pass Project. In addition, Cheniere has not requested authorization for any additional increased capacity, and the time necessary to obtain the permits and approvals for further additional facilities would substantially delay meeting the proposed timeline for the Terminal Expansion. Based on these considerations, the Corpus Christi LNG Project was removed from further consideration as a potential system alternative.

### **Lavaca Bay LNG Project**

The proposed Lavaca Bay LNG Project (Docket Nos. CP14-71-000 and CP14-72-000) would include two floating liquefaction, storage, and offloading (FLSO) units. The project also would include about 110 acres of onshore pre-treatment facilities and infrastructure associated with the FLSSOs, 80 acres of marine facilities, and installation of a new 29-mile-long pipeline to transport natural gas from existing pipeline systems to the Lavaca Bay LNG Project facilities. The total area affected during construction, including pipeline facilities, would be about 518 acres. LNG would be stored, as needed, prior to transferring it to carriers for export. The FLSSOs would be permanently moored at a proposed shore-side dock in Port Lavaca in Calhoun County, Texas, about 185 miles southeast of the Golden Pass Import Terminal. On September 2, 2015, Lavaca Bay filed to withdraw its application and therefore is no longer a viable alternative.

### **Magnolia LNG Project**

Magnolia is proposing to construct a liquefaction and LNG export project (Docket No. CP14-347-000) at the Port of Lake Charles in Calcasieu Parish, Louisiana, about 43 miles northeast of the Golden Pass Import Terminal. The Magnolia LNG Project would be a stand-alone LNG export facility not associated with an existing LNG terminal that would be constructed on a 90-acre site. At full capacity, the project would export 8 mtpy of LNG using four liquefaction trains, each with a nominal capacity of 2.0 mtpy of LNG. The proposed project would include two LNG storage tanks, four LNG liquefaction trains, an LNG vessel loading terminal and berth, an LNG truck loading area, and ancillary facilities.

Magnolia filed its application with the FERC on April 30, 2014 and the FERC issued the Final EIS for the project on November 13, 2015. If approved, Magnolia could start construction of the LNG terminal in the first quarter of 2016 and place the first liquefaction train into service in December 2018. The remaining three liquefaction trains would be commissioned at 3-month intervals after completion of the first liquefaction train, with full service anticipated after a total construction period of 45 months.

Magnolia is negotiating long-term tolling agreements with three companies and has signed a fourth non-binding tolling term sheet with the AES Group (Sutherland, 2014). As such, the Magnolia LNG Project would not have the available capacity to meet the objectives of the Golden Pass Project without substantial expansion. In addition, adequate land is not available for an expansion at the Magnolia site because the export facility is immediately adjacent to the Calcasieu Point Landing public boat ramp and associated facilities, as well as the planned Louisiana Marine Fisheries Enhancement, Research, and Science Center. Further, as a greenfield facility, the environmental impacts associated with development on a largely undisturbed site, including berthing facilities, would likely be greater in both magnitude and duration than those of the Terminal Expansion. Therefore, Magnolia does not offer a significant environmental advantage to the Terminal Expansion. In addition, Magnolia has not requested authorization for the increased capacity, and the time necessary to obtain the permits and approvals for the additional facilities would substantially delay meeting the proposed timeline for the Terminal Expansion. Based on these considerations, the Magnolia LNG Project was removed from further consideration as a potential system alternative.

### **CE FLNG Project**

CE FLNG announced plans for developing a floating LNG liquefaction and export terminal on the east bank of the Mississippi River, north of the confluence with Baptiste Collette Bayou in Plaquemines Parish, Louisiana, and about 279 miles east-southeast of the Golden Pass Import Terminal. Planned project facilities include three FLSO vessels, each capable of producing up to 2.5 mtpy of LNG, and onshore facilities within a site of about 125 acres. The FLSOs would have a total LNG storage capacity of 170,000 m<sup>3</sup>. The project also would include a 37-mile-long pipeline to connect the terminal with two sources of natural gas: (1) the existing Enterprise Products natural gas processing plant in Bernard Parish, Louisiana; and (2) the existing Targa Venice natural gas processing plant in Plaquemines Parish, Louisiana.

The project would be a stand-alone liquefaction facility using different technologies than the Terminal Expansion. The CE FLNG export facility would not be associated with an existing land based LNG terminal. On April 16, 2013, CE FLNG received approval to use the FERC pre-filing process under Docket No. PF13-11-000. CE FLNG indicated that it plans to file its application with the FERC during the fourth quarter of 2016.

The CE FLNG Project would not have the capacity to meet the objectives of the Project without substantial expansion. The environmental impacts associated with expansion in a largely undisturbed area, including substantial development of marine berthing and onshore facilities, would be greater in both magnitude and duration than those of the Terminal Expansion. Therefore, CE FLNG's project would not provide a significant environmental advantage to the Terminal Expansion. In addition, CE FLNG has not requested authorization for the increased capacity, and the time necessary to obtain the permits and approvals for the additional facilities would substantially delay meeting the proposed timeline for the Terminal Expansion. Based on these considerations, the expansion of the CE FLNG Terminal was removed from further consideration as a potential system alternative.

### **Calcasieu Pass Project**

The Calcasieu Pass Project (Docket Nos. CP15-550-000 and CP15-551-000), proposed by Venture Global, is a stand-alone liquefaction and LNG export facility that would be in Cameron Parish, Louisiana, about 33 miles east of the Golden Pass Import Terminal. The Project would have an export capacity of 10 mtpy and would be constructed on a 938-acre site on the east side of the entrance to the Calcasieu Ship Channel. Natural gas would be provided by two new pipelines: a 23.8-mile-long, 42-inch-diameter pipeline and an 18.5-mile long, 42-inch-diameter pipeline. Natural gas would be liquefied using 10 integrated refrigerant blocks, each with a nominal capacity of 1.0 mtpy. Support facilities would include two new 200,000 m<sup>3</sup> LNG storage tanks, two LNG berthing docks, and an electric generation facility.

Venture Global anticipates starting construction in October 2016 if it receives all authorizations, permits, and approvals. Full operation is proposed for December 2019, with partial operation planned to precede that using a temporary floating LNG storage vessel until the first new LNG storage tank becomes operational.

As a greenfield facility, the environmental impacts associated with construction and operation on a largely undisturbed site, including two pipelines, LNG storage tanks, liquefaction facilities, and berthing facilities, would be greater in both magnitude and duration than those of the Terminal Expansion. In addition, the Calcasieu Pass Project would need to substantially expand its facilities to provide the LNG needed to meet the export objectives of the Golden Pass Project, further increasing the impacts of the Calcasieu Pass Project. The Calcasieu Pass Project does not represent a significant environmental advantage to the Terminal Expansion. In addition, Venture Global has not requested authorization for the increased capacity, and the time necessary to obtain the permits and approvals for the additional facilities would substantially delay meeting the proposed timeline for the Terminal Expansion. Based on these considerations, the expansion of Venture Global's proposed LNG export facility was removed from further consideration as a potential system alternative.

### **SCT&E LNG Export Project**

Based on information in the public domain, the planned SCT&E LNG Export Project would be a stand-alone export project on a 246-acre site. It would be located on Monkey Island in the Calcasieu Ship Channel, about 3 miles from the Gulf of Mexico and about 34 miles east of the Golden Pass Import Terminal. The project would have an export capacity of 12 mtpy; it would include six LNG trains, at least one 160,000 m<sup>3</sup> LNG storage tank, LNG berthing facilities, and pipeline laterals and interconnections to existing natural gas pipelines. At the time this EIS was prepared, SCT&E had not requested that the FERC initiate the pre-filing process.

As a greenfield facility, the environmental impacts associated with construction and operation on a largely undisturbed site, including the lateral pipelines, LNG storage tank, liquefaction facilities, and berthing facilities, are not completely defined, but likely would be greater in both magnitude and duration than those of the Golden Pass Project. In addition, SCT&E would need to further expand its facilities to provide the LNG needed to meet the export objectives of the Terminal Expansion, thus increasing the impacts of the SCT&E project. Therefore, the SCT&E LNG Export Project does not represent a significant environmental advantage to the Golden Pass Project.

Although the SCT&E facilities are not fully defined at this time, an in-service year of 2022 has been proposed by SCT&E. Completion of the permitting and authorization processes necessary for constructing and operating the project and additional facilities would substantially delay meeting the proposed timeline for the Terminal Expansion. Based on these considerations, the SCT&E LNG Project was not removed from further consideration as a potential system alternative.

### **Mississippi River LNG Project**

The Mississippi River LNG Project (Docket No. PF14-17-000), an LNG export project planned by Louisiana LNG, would be constructed on a 200-acre site on the east bank of the Mississippi River near River Mile 46, about 241 miles east of the Golden Pass Import Terminal. The project would include four liquefaction trains, two 100,000 m<sup>3</sup> full-containment LNG storage tanks, one marine berthing facility, LNG truck loading facilities, 1.9 miles of 24-inch-diameter pipeline, and 1.6 miles of 12-inch-diameter pipeline. The project would have a total export capacity of 2 mtpy.

If the project is authorized, Louisiana LNG anticipates beginning operation in the second quarter of 2018. However, at the time this EIS was prepared, Louisiana LNG had not filed its application with the

FERC. As a greenfield facility, the environmental impacts associated with development on a largely undisturbed site and a berthing facility would likely be greater in both magnitude and duration than those of the Golden Pass Project. Further, to meet the purpose and need of the Golden Pass Project, Louisiana LNG would have to construct additional facilities capable of an output of about 13.6 mtpy of LNG. Construction and operation of the planned and additional facilities would not provide a significant environmental advantage to the Golden Pass Project. Based on these considerations, the Mississippi River LNG Project was removed from further consideration as a potential system alternative.

### **Eos LNG Export Project**

The planned Eos LNG Export Project would be a liquefaction and LNG export project at the Port of Brownsville in Brownsville, Texas, about 335 miles southwest of the Golden Pass Import Terminal. The project would be a stand-alone LNG export facility that is not associated with an existing LNG terminal, with an LNG export capacity of 2 mtpy per FLSO unit.

The facility is being designed and permitted for up to six FLSO units with aggregate peak capacity of up to 12 mtpy. It would include up to six 35,000 m<sup>3</sup> full containment LNG storage tanks and up to six LNG carrier docks. Each floating liquefaction barge would be moored alongside an LNG carrier that would be utilized solely for storage. LNG would be transferred to and exported by a second carrier, moored alongside the barge and storage carrier. The project would not require land-based liquefaction or storage facilities. Two jetties would be installed to establish berthing facilities for the floating liquefaction barges and the LNG carriers used for storage. Both jetties would include utilities for the vessels as well as the necessary facilities for loading and unloading. Feed gas would be sourced from local pipeline interconnections.

At the time this EIS was prepared, Eos had not requested that the FERC initiate the pre-filing process.

The Eos LNG Export Project would not provide the volume of LNG required by the Golden Pass Project for export. To meet the purpose and need of the Golden Pass Project, Eos would need to construct seven additional berthing facilities (two jetties each) to accommodate the seven additional FLNGs and LNG carriers required to provide an additional 13.6 mtpy of LNG. The magnitude and duration of impacts due to construction and operation of the planned and additional facilities would be substantially greater than those of the Golden Pass Project and would not provide a significant environmental advantage to the proposed Project. Based on these considerations, the Eos LNG Export Project was removed from further consideration as a potential system alternative.

### **Texas LNG Project**

The planned Texas LNG Project would be a liquefaction and LNG export project at the Port of Brownsville in Brownsville, Texas, about 329 miles southwest of the Golden Pass Import Terminal. The project would be a stand-alone LNG export facility that is not associated with an existing LNG terminal, with an LNG export capacity of 4 mtpy.

A 625-acre site would house project facilities, including gas treatment, two liquefaction trains, two LNG storage tanks, a supply dock, and a marine berthing facility for LNG carriers. The project also would require a pipeline connection to existing sources of natural gas.

On April 14, 2015, Texas LNG received approval to use the FERC pre-filing process under (Docket No. PF15-14-000). Texas LNG anticipates starting construction in mid-2017, with operation to begin in 2020.

The Texas LNG Export Project would not provide the volume of LNG required by the Golden Pass Project for export. To meet the purpose and need of the Golden Pass Project, Texas LNG would need to construct additional facilities capable of an output of about 11.6 mtpy of LNG. The magnitude and duration of impacts due to construction and operation of the planned and additional facilities would be similar to or greater than those of the Golden Pass Project and would not provide a significant environmental advantage to the Project. In addition, Texas LNG has not requested authorization for the increased capacity, and the time necessary to obtain the permits and approvals for the additional facilities would substantially delay meeting the proposed timeline for the Terminal Expansion. Based on these considerations, the Texas LNG Project was removed from further consideration as a potential system alternative.

### **Delfin Liquefaction Project**

The planned Delfin Liquefaction Project would be a “deep-water port” as defined by the Deepwater Port Act. Delfin would use floating liquefaction and storage vessels (FLNGVs) moored near an existing platform approximately 50 miles offshore of Cameron Parish, Louisiana and about 53 miles south of the Golden Pass Import Terminal. The platform is the terminus and metering point of the existing Enbridge Offshore Pipelines natural gas pipeline system and is connected to the shore via an existing 42-inch-diameter, 30-mile-long natural gas pipeline that previously was used for transporting offshore natural gas production to onshore connections with interstate natural gas pipelines and nearby gas processing plants. Due to changing market conditions, the FERC authorized abandonment of the pipeline’s services and certificates in 2011, while deferring final disposition of the facilities. The pipeline is currently filled with nitrogen, and Delfin intends to reverse the flow of the pipeline to deliver feed gas to the proposed project.

The FLNGVs would be moored as near the platform as possible using single-point moorings (mooring towers); they have the capability to load LNG onto LNG carriers using a side transfer process. The project would require construction of four mooring towers and lateral subsea pipelines connecting to the existing 42-inch-diameter pipeline. In addition, an exclusion zone would be established around each FLNGV.

Delfin has a planned export capacity of about 9 mtpy, which could be expanded to about 13 mtpy if warranted by market conditions. The project would include four liquefaction trains, with one train per FLNGV. Each of the trains would have a maximum export capacity of 3 mtpy. Delfin would construct 120,000 hp onshore compressor station and pipeline laterals to provide natural gas to the offshore facilities. Delfin would construct the project in stages, with initial production anticipated to occur in the third quarter of 2019 and full operation to occur in 2022.

As a deepwater port, the project would require a license from the DOT’s Marine Administration (MARAD) in conjunction with the Coast Guard. On May 8, 2015, Delfin submitted an application for the project to MARAD and the Coast Guard. Delfin subsequently filed a revised application, reflective of the currently proposed project, on November 19, 2015.

The offshore components of the project would not require authorization by the FERC. However, the onshore compressor station and associated pipeline modifications would. On May 8, 2015, Delfin also filed an application with the FERC under Docket No. CP15-490-000. Delfin subsequently filed a revised application, reflective of the currently proposed project, on November 19, 2015. The Commission stated that it would not begin processing Delfin’s LNG application until MARAD and the Coast Guard accept Delfin’s Deepwater Port application.

Delfin reported that it had signed a preliminary agreement with LITGAS to contract a portion of the processing capacity of the project. Depending on the volume of LNG taken by LITGAS, Delfin would need to construct all four of the mooring towers plus additional towers to moor the number of FLNGVs necessary to provide the 15.6 mtpy proposed by the Golden Pass Project. The impacts of constructing and

operating the compressor station and the planned and additional marine facilities, including the impact of the exclusion zones, would result in overall impacts that would likely be similar to or greater than those of the proposed Project. Further, the additional facilities have not been proposed, and completion of the permitting and authorization processes necessary for constructing and operating the project and additional facilities would substantially delay meeting the proposed timeline for the Terminal Expansion. Based on these considerations, the Delfin Liquefaction Project was removed from further consideration as a potential system alternative.

### **Port Arthur Liquefaction Project**

The planned Port Arthur Liquefaction Project would be constructed in Jefferson County, Texas, near the City of Port Arthur, along the west side of the SNWW about 8 miles north of the Golden Pass Import Terminal. The project would include two liquefaction trains, each with a nominal capacity of 5 mtpy of LNG, for a total capacity of 10 mtpy. In addition, the project would include two 160,000 m<sup>3</sup> LNG storage tanks, a marine berthing facility for two LNG carriers, and a supply dock. Natural gas would be supplied by a new pipeline system planned by Port Arthur Pipeline. The project would be constructed on a portion of a 2,900-acre site. The new pipeline system would consist of two 42-inch-diameter pipelines (one would be 7 miles long, the second would be 27 miles long), two compressor stations, and associated facilities in Orange and Jefferson Counties, Texas, and in Cameron Parish, Louisiana.

On March 31, 2015, Port Arthur LNG and Port Arthur Pipeline, LLC received approval to use the FERC pre-filing process under Docket Nos. PF15-18-000 and PF15-19-000, respectively. Port Arthur LNG anticipates that construction would begin in January 2017, with the first liquefaction train in service in the first quarter of 2021. Full service would be in the third quarter of 2021.

The Port Arthur Liquefaction Project would be constructed on a largely undisturbed site and would affect substantially more land than the Golden Pass Project. Land impacts would result from construction of the two pipelines and the compressor stations, and disturbance associated with the new marine berthing facilities would be greater than the marine disturbances associated with the proposed Project. In addition, to meet the purpose and need of the Golden Pass Project, the Port Arthur Liquefaction Project would need to construct and operate facilities to produce an additional 5.6 mtpy of LNG. Those additional facilities would add to the potential impacts from construction and operation of the Port Arthur Liquefaction Project as currently planned. As a result, the environmental impacts associated with the Port Arthur Liquefaction Project would be greater in both magnitude and duration than those of the Golden Pass Project, and the Port Arthur Liquefaction Project would not offer a significant environmental advantage over the Golden Pass Project. Further, the additional facilities have not been proposed, and completion of the permitting and authorization processes necessary for constructing and operating the project and additional facilities would substantially delay meeting the proposed timeline for the Terminal Expansion. Based on these considerations, the Port Arthur Liquefaction Project was removed from further consideration as a potential system alternative.

### **G2 LNG Project**

The planned G2 LNG Project (Docket No. PF16-2-000) would be a new LNG export facility to be constructed on the Calcasieu Ship Channel in Cameron Parish, Louisiana, about 35 miles east of the Golden Pass Import Terminal. The project would be a stand-alone LNG export facility that is not associated with an existing LNG terminal, with an LNG export capacity of 14 mtpy. Anticipated facilities include two liquefaction trains, new LNG storage tanks with approximately 10 days of storage at full capacity, and LNG carrier berthing and loading facilities. The project would be constructed on a 500-acre property adjacent to the ship channel.

The G2 LNG Project would be constructed on a largely undisturbed site, and construction of the new marine berthing facilities would result in greater marine disturbances than those associated with the Golden Pass Project. In addition, the G2 LNG Project would not provide the volume of LNG required by the proposed Project for export without construction of additional liquefaction capacity. As a result, the environmental impacts associated with development of the G2 LNG Project would be greater in both magnitude and duration than those of the proposed Project. This project does not offer a significant environmental advantage over the proposed Project. In addition, G2 LNG has proposed to begin construction in the fourth quarter of 2017 and therefore would not commence full facility operations until 2021; as such, the G2 LNG Project would be substantially behind the schedule for the Terminal Expansion and would not be able to provide the proposed volume of LNG in the same timeframe as the Terminal Expansion. Based on these considerations, the G2 LNG Project was removed from further consideration as a potential system alternative.

### **Annova LNG Brownsville Project**

The Annova LNG Brownsville Project would be constructed on 580 acres next to the Brownsville Ship Channel in Cameron County, Texas, about 330 miles southwest of the Golden Pass Import Terminal. The project would include six liquefaction trains, each with a nominal capacity of 1 mtpy, for a total capacity of 6 mtpy and a maximum output under optimal operating conditions of 7 mtpy. In addition, there would be two 160,000 m<sup>3</sup> storage tanks, a marine berthing facility for one LNG carrier, a tug berth, a dock for support and security vessels, and a construction work dock. Natural gas would be supplied by the planned BND South Delivery Header from the Isla Grande Pipeline (a non-jurisdictional, intrastate pipeline). On March 27, 2015, Annova LNG received approval to use the FERC pre-filing process under (Docket No. PF15-15-000).

The Annova LNG Brownsville Project would be constructed on a largely undisturbed site, and disturbance associated with construction of the new marine berthing facilities would likely be greater than the marine disturbances associated with the Golden Pass Project. In addition, the Annova LNG project would not have the available capacity to meet the export objectives of the Project without substantial expansion, which would further increase potential impacts. As a result, the environmental impacts associated with development of the Annova LNG Brownsville Project would likely be greater in both magnitude and duration than those of the Golden Pass Project, and the Annova LNG project would not provide a significant environmental advantage to the proposed Project. In addition, Annova LNG has proposed to begin construction in the second quarter of 2017 and therefore would not commence full facility operations until 2021; as such, the Annova LNG Project would be substantially behind the schedule for the Terminal Expansion and would not be able to provide the proposed volume of LNG in the same timeframe as the Terminal Expansion. Based on these considerations, the Annova LNG Brownsville Project was removed from further consideration as a potential system alternative.

### **Rio Grande LNG Export Project**

Rio Grande LNG would construct the Rio Grande LNG Export Project within a 1,000-acre parcel of land adjacent to the Brownsville Ship Channel in Cameron County, Texas, about 330 miles southwest of the Golden Pass Import Terminal. The project would include six liquefaction trains, each with a nominal capacity of 4.5 mtpy of LNG, for a total capacity of about 27 mtpy. Other facilities would include four 180,000 m<sup>3</sup> LNG storage tanks, two marine jetties for berthing LNG carriers, and onsite power generation. Construction of the export terminal would disturb about 850 acres of land. The project also would include two parallel 42-inch-diameter pipelines extending 130 miles from the export terminal to the terminus of an existing Rio Bravo pipeline, along with a 100,000-hp compressor station and a 150,000-hp compressor station.



On April 13, 2015, Rio Grande LNG received approval to use the FERC pre-filing process under Docket No. PF15-20-000. Rio Grande LNG anticipates starting construction of the project in the third quarter of 2017 and initiating service from the first liquefaction train in the fourth quarter of 2020.

The Rio Grande LNG Export Project would be constructed on an undisturbed site and would affect substantially more land than the proposed Project. Additional land impacts would be caused by construction of the two pipelines and the compressor stations. In addition, construction of the new marine berthing facilities would result in greater marine disturbances than those associated with the Golden Pass Project. As a result, the impacts of the Rio Grande LNG Export Project would be greater in both magnitude and duration than those of the Golden Pass Project. Therefore, this project does not offer a significant environmental advantage over the proposed Project. Based on these considerations, the Rio Grande LNG Export Project was removed from further consideration as a potential system alternative.

### **Gasfin LNG Project**

Gasfin is planning to develop a liquefaction and LNG export facility on the east side of the Calcasieu Ship Channel in Cameron Parish, Louisiana, about 35 miles east of the Golden Pass Import Terminal. This mid-scale project would have overall LNG storage capacity of 100,000 m<sup>3</sup> and LNG export capacity of 1.5 mtpy. The onshore facilities would be constructed on a 35-acre site and the project would also include a single marine berth capable of handling LNG carriers with a capacity between 10,000 and 35,000 m<sup>3</sup>. The project is in the initial development phase and an anticipated schedule has not yet been released. At the time of writing, Gasfin had not requested that the FERC initiate the pre-filing process.

We do not consider the Gasfin LNG Project to be a reasonable alternative to the Terminal Expansion because it would not have the capacity to meet the objectives of the Project without substantial expansion. The environmental impacts associated with expansion, including increasing the size and capacity of the marine berthing and onshore facilities, would be greater in both magnitude and duration than those of the Terminal Expansion and therefore would not provide a significant environmental advantage. In addition, the permitting and review process for the Gasfin LNG Project would begin substantially later than the process for the Terminal Expansion. Based on these considerations, expansion of the planned Gasfin LNG export facility was removed from further consideration as a potential system alternative.

### **Gulf Coast Liquefaction Project**

The Gulf Coast Liquefaction Project would export LNG from a planned liquefaction facility at the Port of Brownsville in Brownsville, Texas, about 320 miles southwest of the Golden Pass Import Terminal. The project would include a new terminal on about 500 acres, with four liquefaction trains each capable of producing 4.5 mtpy of LNG (18.0 mtpy total), an unspecified number of LNG storage tanks, a marine berth, and a pipeline interconnection with existing natural gas transmission lines. At the time of writing, Gulf Coast had not requested that the FERC initiate the pre-filing process.

Gulf Coast would potentially be capable of meeting the proposed Golden Pass capacity; however, as a greenfield facility, the Gulf Coast Liquefaction Project would be unlikely to provide a significant environmental advantage over the Terminal Expansion. In addition, since Gulf Coast has not begun the FERC permitting and review process, the timeline for construction of this project would likely be substantially later than for the Terminal Expansion. Based on these considerations, expansion of the planned Gulf Coast LNG export facility was removed from further consideration as a potential system alternative.

## **Live Oak LNG Project**

Live Oak has announced plans for a liquefaction and LNG export facility in Calcasieu Parish, approximately 44 miles northeast of the Golden Pass Import Terminal. Live Oak's project would include eight liquefaction units capable of producing a nominal capacity of 5.2 mtpy of LNG, two 130,000-m<sup>3</sup> LNG storage tanks, a marine berth accommodating an LNG vessel with cargo capacity of up to 175,000 m<sup>3</sup>, and an interconnection with the Kinder Morgan Louisiana Pipeline LLC (KMLP) and the Creole Trail Pipeline systems. The project is in the initial development phase and, if authorized, is expected to begin export of up to 5.0 MTPA of LNG at the end of 2019; however, at the time of this writing, Live Oak has not requested initiation of the FERC pre-filing process.

The Live Oak LNG Project would not have the capacity to meet that of the Terminal Expansion without substantial increase in scope. As a greenfield facility, the environmental impacts associated with the development of the Live Oak LNG Project would likely be greater in both magnitude and duration than those of the Project and would therefore be unlikely to provide a significant environmental advantage over the Terminal Expansion. In addition, since Live Oak has not begun the FERC permitting and review process, the timeline for construction of this project would likely be substantially later than for the Terminal Expansion. Based on these considerations, expansion of the Live Oak LNG export facility was removed from further consideration as a potential system alternative.

## **Waller Point LNG Project**

The Waller Point LNG Project is a planned liquefaction and LNG export facility on a 180-acre greenfield site near the mouth of the Calcasieu Ship Channel in Cameron Parish, Louisiana, about 35 miles east of the Golden Pass Import Terminal. The project would include small-scale liquefaction trains with a total LNG export capacity of about 1.5mtpy, LNG storage capacity of 30,000 m<sup>3</sup>, and berthing facilities for LNG barges. The project is in the initial development phase and Waller Point LNG has not announced a planned schedule. Furthermore, at the time of writing, initiation of the FERC pre-filing process had not been requested.

We do not consider the Waller Point LNG Project to be a reasonable alternative to the Terminal Expansion because it would not have the capacity to meet the objectives of the Project without substantial increase in scope. As a greenfield site, the environmental impacts associated with development of the Waller Point LNG Project would likely be greater in both magnitude and duration than those of the Terminal Expansion and therefore would not provide a significant environmental advantage. In addition, since Waller Point has not begun the FERC permitting and review process, the timeline for construction of this project would likely be substantially later than for the Terminal Expansion. Based on these considerations, expansion of the planned Waller Point LNG export facility was removed from further consideration as a potential system alternative.

### **3.2.1.3 Announced Export Projects**

We are aware of the following export projects that were announced in the press by their proponents, but have not yet progressed beyond that point.

- SEG Sideco LNG Project, announced by SEG Sideco LNG; and
- Pelican Island Project, planned by NextDecade.

Because no additional information on these projects is available beyond the initial announcements, we cannot determine the potential environmental effects and therefore did not consider them in the analysis of potential system alternatives.

#### **3.2.1.4 Agency Preferred Alternative**

Based on the evaluations described above, we concluded that the potential system alternatives were not reasonable alternatives or did not offer a significant environmental advantage over the Golden Pass Project. Therefore, the proposed Terminal Expansion is the preferred liquefaction terminal system alternative to meet the Project's objectives.

#### **3.2.2 Pipeline System Alternatives**

To serve as a viable pipeline system alternative to the Pipeline Expansion, the system would need to (1) transport all or a part of the volume of natural gas required for liquefaction at the Terminal Expansion; and (2) cause significantly less impact on the environment than the proposed Pipeline Expansion. Gas provided by a system alternative must connect to the existing Golden Pass Pipeline or directly to the Terminal Expansion.

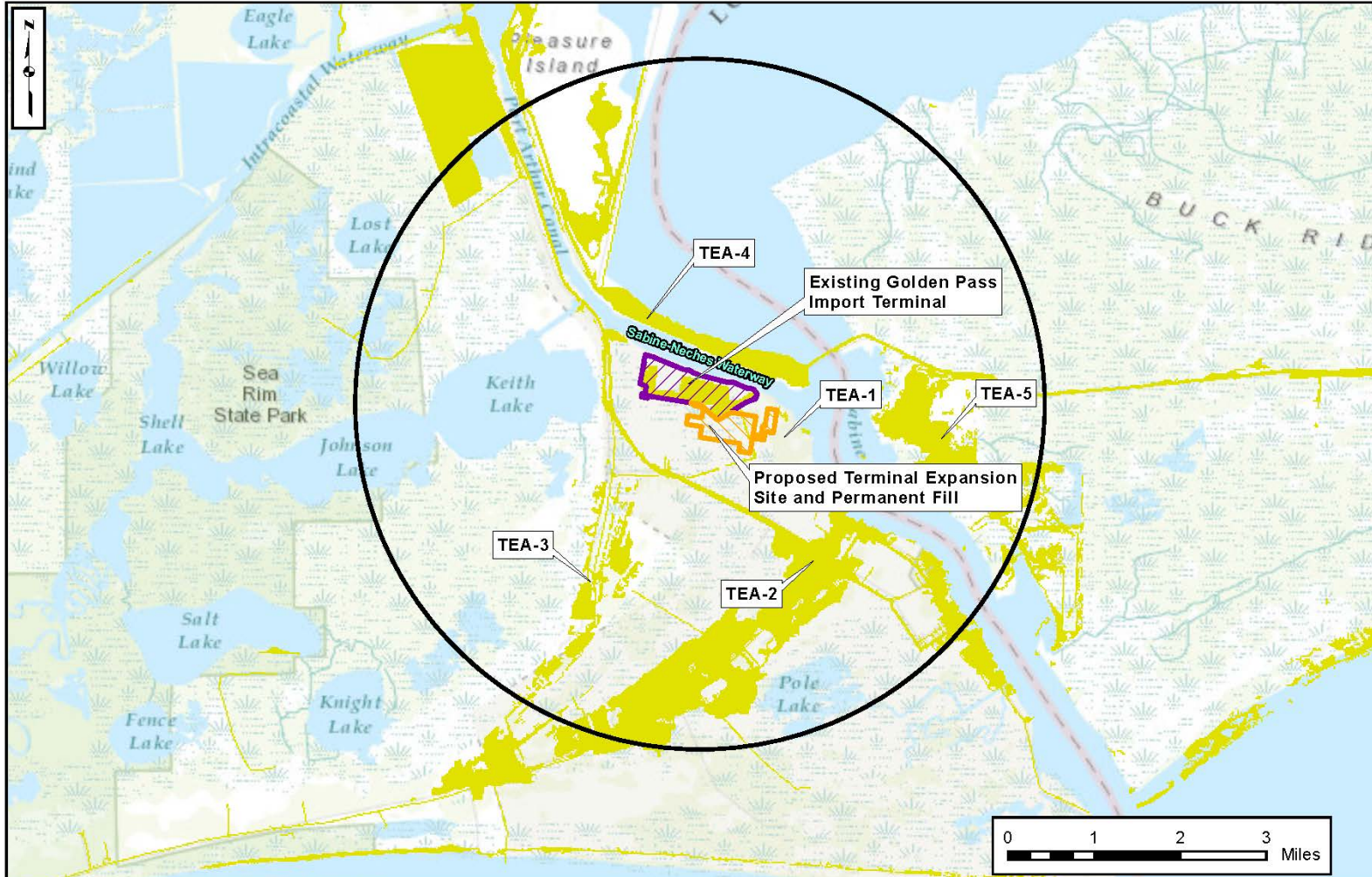
The existing Golden Pass Pipeline has interconnections with the NGPL, Tejas, Golden Triangle Storage, Texoma, FGT, TGP, TETCO, and Transco pipeline systems. However, no single pipeline in proximity to the existing Golden Pass Import Terminal could supply up to 2.7 bcfd at a delivery pressure of 1,000 psig. Potential pipeline system alternatives include construction of a new lateral extension to the Terminal Expansion from an existing or proposed pipeline system and construction of a new pipeline system that would connect a market hub, supply basin, or multiple natural gas supply pipelines directly to the Terminal Expansion. The Pipeline Expansion route would be within or parallel and adjacent to the existing Golden Pass Pipeline right-of-way for its entire length. As a result, we considered the impacts of the Pipeline Expansion to be minor (as described throughout section 4.0) and the impacts of constructing a new lateral pipeline or new mainline to be substantially greater than those of the Pipeline Expansion. Therefore, we did not further consider pipeline system alternatives.

### **3.3 ALTERNATIVE TERMINAL EXPANSION SITES**

#### **3.3.1 Sites in the Vicinity of the Existing Golden Pass Import Terminal**

We evaluated the feasibility of constructing the Terminal Expansion at alternative sites. Proximity to the existing Golden Pass Import Terminal was a criterion in the evaluation to enable use of existing infrastructure, such as the LNG storage tanks, the LNG carrier berths and cargo loading/unloading facilities, and other associated facilities. Construction and operation of alternative, new facilities would substantially increase the environmental impacts of the Project compared to the proposed use of the LNG infrastructure and facilities at the existing terminal.

We evaluated alternative sites for the Terminal Expansion within upland areas in a 4-mile radius of the existing terminal (see figure 3.3-1). Four miles is an accepted maximum length for efficient functioning of cryogenic LNG pipelines used to transport LNG from the liquefaction facilities to the LNG storage tanks. Four of the five sites identified as potential alternatives are comprised of substantial existing development or are close to existing development, including residences, schools, commercial and retail facilities, parks and roads. We concluded that these sites would be impractical, and they were eliminated from further consideration. The only upland site (TEA-1) we identified within the 4-mile radius as a potentially viable alternative is about 0.3 mile southeast of the Terminal Expansion. Although this alternative site includes about 84 acres of upland area, the amount of available upland is not adequate to construct the liquefaction trains and associated facilities. Thus, construction at this site would disturb about 436 acres of wetlands as compared to the 311 acres of wetlands that would be affected by construction at the proposed Terminal Expansion site. This site was therefore eliminated from further consideration.



**Figure 3.3-1**  
**Golden Pass LNG Export Project**  
 Terminal Expansion Alternative Sites in Upland Areas

### **3.4 ALTERNATIVE SUPPLY DOCK SITES**

The existing Golden Pass Import Terminal can be accessed by land only by traveling south from Port Arthur, Texas, via SH-87. The Texas Department of Transportation stated that, due to damage incurred from Hurricane Ike in 2008, the current condition of SH-87 is such that large, overweight deliveries of equipment and materials to the proposed Golden Pass Export Terminal via SH-87 would not be permissible. Therefore, deliveries of large, overweight equipment and materials would require transport via rail car or marine vessel. There are no rail spurs in the vicinity of the Terminal Expansion site. Railway transportation would require construction of a new rail line, including a railway crossing over the Gulf Intracoastal Waterway, which would be cost prohibitive; if such a project could obtain the required permits, it would likely affect navigation within the waterway.

Consequently, Golden Pass proposes to construct a supply dock for the delivery of bulk materials via barge along the SNWW. Details regarding the proposed Supply Dock are provided in section 2.2.1.5. We evaluated three alternatives for the Supply Dock in addition to use of the proposed site: (1) use of the Golden Pass Import Terminal existing Ship Slip; (2) improvements to and use of an existing marine dock (Broussard Dock) adjacent to the Golden Pass Import Terminal; and (3) improvements to and use of an existing tug berth adjacent to the Golden Pass Import Terminal existing Ship Slip (see figure 3.4-1).

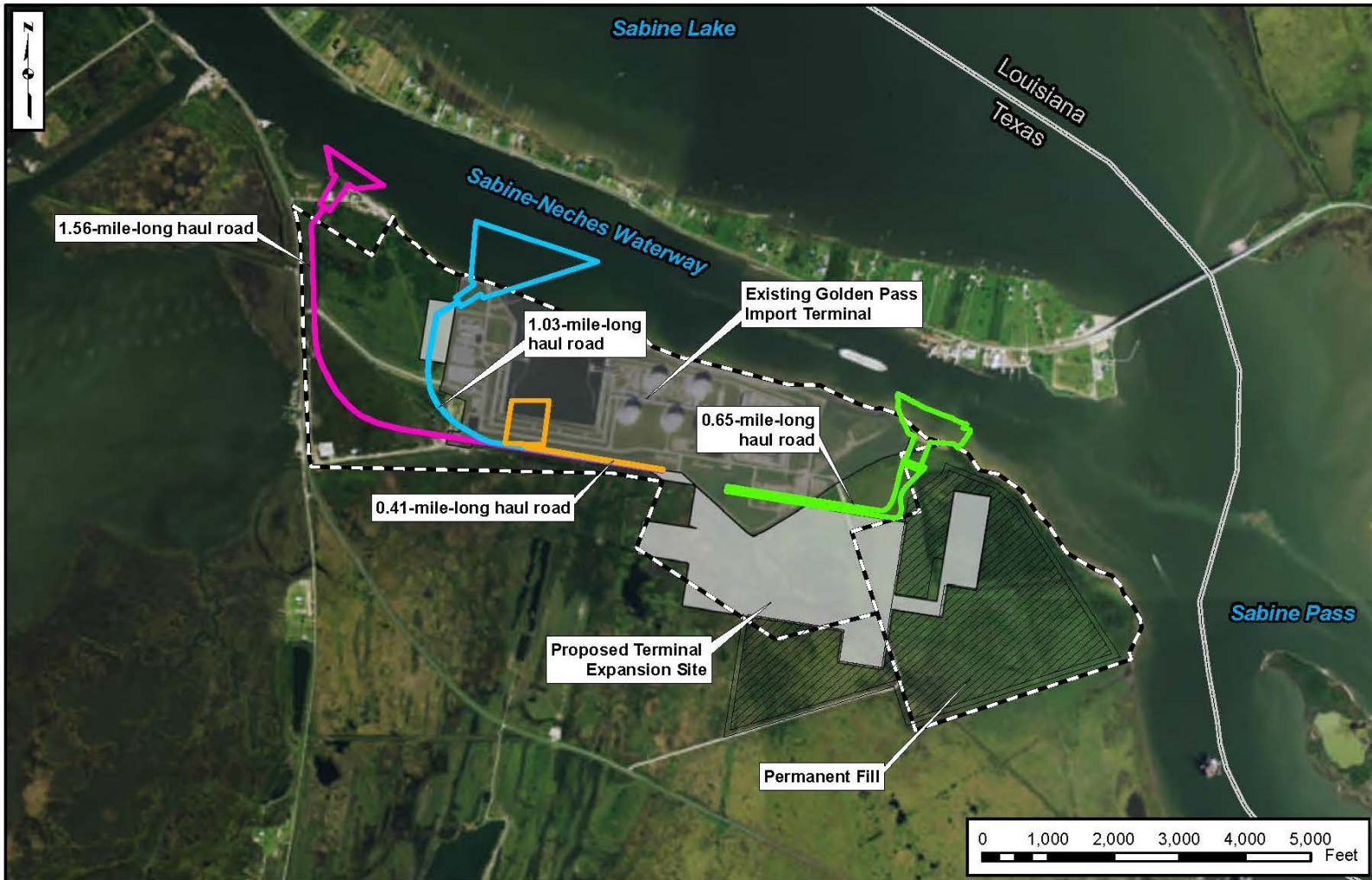
#### **3.4.1 Golden Pass Import Terminal Existing Ship Slip**

The existing Golden Pass Import Terminal Ship Slip is within the Golden Pass property boundary. Existing utility access is available and dredging would not be required for the facility beyond the maintenance dredging already permitted for the terminal. A 2,165-foot-long new haul road from the Ship Slip to the Terminal Expansion site would need to be constructed. The alternate haul road would not affect any wetlands, whereas the proposed haul road would affect 5 acres of wetlands. However, this alternative was determined to not be feasible for several technical reasons:

- the marine berths do not have the capacity to accept transfers of heavier bulk materials and equipment necessary for construction of the Terminal Expansion without major modifications (although soil and sand could be transferred), which would affect the LNG loading/unloading facilities and operation of the marine transfer facilities; and
- construction-related deliveries would need to be terminated during startup of the first liquefaction train to allow LNG carriers to use the berthing facilities; therefore, a new marine docking facility would need to be constructed for delivery of large and/or heavy equipment and structures.

As a result, the use of the existing Ship Slip, without major construction alterations, is not a feasible alternative for the proposed Supply Dock and would result in more adverse environmental impacts, not offering a significant environmental advantage. Therefore, we did not consider this alternative further.





- █ Improvement of an Existing Marine Berth (Broussard Dock)
- █ Improvement of the Existing Tug Berth
- █ Proposed Site
- █ Use of Existing LNG Ship Slip
- Golden Pass LNG Property
- Proposed Terminal Expansion Site

**Figure 3.4-1**  
**Golden Pass LNG Export Project**  
 Alternative Sites for the  
 Supply Dock

### 3.4.2 Improvement of the Existing Broussard Dock

The Broussard Dock is on the northwest boundary of the existing Golden Pass Import Terminal and has existing utility access. Dredging to accommodate construction barges would require removal and disposal of an estimated 183,000 yd<sup>3</sup> of sediment, or about 120,000 yd<sup>3</sup> less than required for the proposed Supply Dock. Use of the Broussard Dock would require about 5 acres of dredging, compared to 13.2 acres expected for the Supply Dock; therefore, we anticipate that the impacts on EFH and water quality would be similarly minimal as those associated with construction and operation of the proposed Supply Dock. The estimated length of the heavy haul road from the Broussard Dock to the Terminal Expansion site would be about 1.6 miles, which is about 1.1 miles longer than the proposed haul road; the alternate heavy haul road would affect about 15 acres of wetlands compared to the 5 acres of wetlands affected by the proposed haul road (see table 3.4.2-1).

<b>TABLE 3.4.2-1</b>							
<b>Potential Impacts of the Proposed and Alternative Supply Docks <u>a</u></b>							
<b>Wetland Classification <u>b</u></b>	<b>Acres Affected</b>						<b>Total Acres</b>
	<b>Aggregate</b>	<b>Dredge</b>	<b>Haul Road</b>	<b>Platform</b>	<b>Slip</b>	<b>Laydown Storage</b>	
<b>Proposed Supply Dock</b>							
Open water	0.1	13.1	0.0	0.0	0.4	0.0	13.6
Upland	0.1	0.1	0.3	0.3	1.0	0.0	1.8
PEM	1.4	0.0	5.0	0.0	0.7	0.0	7.1
PUBx	0.0	0.0	0.0	0.0	0.0	0.0	0.0
<b>TOTAL</b>	<b>1.6</b>	<b>13.2</b>	<b>5.3</b>	<b>0.3</b>	<b>2.1</b>	<b>0.0</b>	<b>22.5</b>
<b>Existing Broussard Dock Alternative</b>							
Open water	0.0	5.2	0.0	0.0	0.0	0.0	5.2
Upland	1.2	0.0	2.4	0.5	2.2	1.1	7.4
PEM	0.5	0.0	14.5	0.0	0.0	9.3	24.3
PUBx	0.0	0.0	0.0 <u>c</u>	0.0	0.0	0.0	0.0 <u>c</u>
<b>TOTAL</b>	<b>1.7</b>	<b>5.2</b>	<b>16.9</b>	<b>0.5</b>	<b>2.2</b>	<b>10.4</b>	<b>36.9</b>
<b>Existing Tug Berth Alternative</b>							
Open water	0.0	20.6	0.0	0.0	0.0	0.0	20.6
Upland	0.7	0.0	0.5	0.5	2.2	1.1	5.0
PEM	0.9	0.0	12.6	0.0	0.0	9.3	22.8
PUBx	0.0	0.0	0.0	0.0	0.0	0.0	0.0
<b>TOTAL</b>	<b>1.7</b>	<b>20.6</b>	<b>13.1</b>	<b>0.5</b>	<b>2.2</b>	<b>10.4</b>	<b>48.5</b>
<b><u>a</u></b> The existing Ship Slip is not compared in this table because it is a logistically infeasible alternative.							
<b><u>b</u></b> PEM: Palustrine Emergent; PUBx: Palustrine Unconsolidated Bottom, excavated							
<b><u>c</u></b> Acreage of impacts was greater than 0.00 but less than 0.05 acre.							

In addition, Golden Pass stated that a key design requirement is the ability to construct a supply dock that is incised into the shoreline, as the proposed Supply Dock has been designed. This design allows for heavy lift cranes to access a barge from multiple sides and isolates a barge from wakes generated from passing ship traffic. Installation of an incised supply dock at the Broussard Dock would require removal and demolition of existing structures, including the existing dock. It would require a similar number of pilings, sheet piles, and pads as the proposed Supply Dock.

While modification of the Broussard Dock to serve as a supply dock for the Terminal Expansion would likely require less dredging, and the dredging would be conducted in an area that has experienced previous dredging, the modifications would require razing and removing the existing onsite structures, including the existing dock, and installing at least an equivalent number of pilings, sheet piles, and pads. Because impacts on wetlands would be greater and impacts on other resources would be similar to those associated with construction and use of the proposed Supply Dock, the Broussard Dock does not offer a significant environmental advantage over construction and use of the proposed Supply Dock. As a result, use of the Broussard Dock is not considered a feasible alternative for the Supply Dock, and we did not further consider this alternative.

### **3.4.3 Improvement of Existing Tug Berth**

The existing tug berth is on the existing terminal property adjacent to the northwest side of the Ship Slip and has existing utility access. Dredging to improve vessel access to the tug berth would require removal of an estimated 530,000 yd<sup>3</sup> of sediment, which is about 225,000 yd<sup>3</sup> more than required for the proposed Supply Dock. The estimated length of the associated heavy haul road would be about 1.1 miles, which is about 0.4 mile longer than the proposed haul road; the alternate haul road would affect about 13 acres of wetlands, compared to the 5 acres of wetlands affected by the proposed haul road (see table 3.4.2-1). The impacts on EFH and water quality are expected to be similarly minimal as those for the proposed Supply Dock.

Tugs are required during transit and berthing of the LNG carriers. Use of the tug berth as a construction supply dock would require demolition of the berth and permanent loss of the tug berth, requiring that a new berth be constructed. Further, because of the proximity of the tug berth to the existing Ship Slip, deliveries to the dock during construction would have the potential to affect operations of the Terminal Expansion, especially after the first train is in service. This alternative offers no significant environmental advantage over the proposed Supply Dock, and improvement of the existing tug berth may have greater safety concerns than use of the proposed Supply Dock. Based on the above, we did not further consider this alternative.

### **3.4.4 Conclusion**

Based on our analysis of the identified alternatives to the proposed Supply Dock, we conclude that the proposed Supply Dock is the environmentally preferred alternative.

## **3.5 ALTERNATIVE TERMINAL CONFIGURATIONS AND POWER SOURCES**

### **3.5.1 Alternative Terminal Configurations**

Although alternative configurations of the Terminal Expansion were evaluated, design of the site was limited by the siting requirements of 49 CFR 193, NFPA 59A, and industry and engineering standards. Regulatory requirements stipulate that potential thermal exclusion and vapor dispersion zones remain onsite; therefore, those requirements dictate the locations of specific pieces of equipment for the liquefaction facilities. Similarly, thermal radiation zones associated with flares require specific distances from other pieces of equipment and from property lines. The selected location of each of the components of the expanded terminal was based on the relevant regulations, codes, and guidelines. We did not identify any alternative configurations that would meet the regulations, codes, and guidelines while avoiding or reducing impacts when compared to those of the proposed terminal configuration. Therefore, we conclude that the proposed general configuration of the Terminal Expansion is the preferred alternative.



### 3.5.2 Alternative Power Sources

Each train would have two steam turbine generators to provide the necessary power requirements for the refrigeration compressors. The steam turbine generators would produce electrical power through cogeneration by using steam from the heat recovery steam generators that are part of the natural gas-fired turbines in each train. All of the turbines would be equipped with selective catalytic reduction and oxidation catalysts to reduce NO<sub>x</sub> and monoxide emissions, respectively. The use of a single, larger gas turbine driving all the required refrigeration compressors would not be technically feasible.

Two alternatives were considered to the gas-fired steam turbines for power supply: (1) power produced by an onsite steam generation plant; and (2) electrical power generated offsite (purchased power). Generating power onsite would require a change to the configuration of the Terminal Expansion in order to incorporate the additional equipment required to convert and transform steam generated onsite into electricity and back into useable power by the electric motors in the compressors. The additional equipment would include a generator, a variable speed motor, and a transformer for each of the six compressors on the liquefaction trains.

Purchased power would come from the local electrical grid. This option also would require additional equipment (a transformer and a variable speed motor for each compressor). An onsite boiler also would be needed to generate process heat as an alternative to that supplied by the heat recovery steam generators. Both options would likely result in lower overall energy efficiency based on the additional equipment needed: the proposed design using gas-powered turbines would result in a compressor cycle efficiency of about 50.3 percent, whereas the alternative options would result in compressor cycle efficiencies of about 50.1 percent for onsite power generation through steam generation, and about 39.3 percent with purchased power.

Both of the alternatives could result in an overall increase in emissions compared to the gas-fired turbines (see table 3.5.2-1). However, emission modeling was not conducted for the alternatives, and it is likely that the difference in emissions, if any, would not be substantial. In addition, although the difference in compressor cycle efficiency between the gas-fired turbines and steam power generation would be relatively small, the steam-powered turbines would need to be run at a higher rate to account for this efficiency loss, which would consume additional fuel and result in an increase in total emissions. For the alternative of using purchased power, the overall fuel requirement for the additional equipment needed (transformer, variable speed motor per compressor, and onsite boiler) would be greater than that needed for the gas-fired steam turbines. Further, the CO<sub>2</sub> emissions from the mixed fuel combusted by public utilities (e.g., coal, diesel, and natural gas) could be greater than those generated by the gas-fired turbines. Therefore, we conclude that the proposed cogeneration power source is the preferred alternative.

<b>TABLE 3.5.2-1</b>			
<b>Comparison of the Fuel Requirements and CO<sub>2</sub> Emissions of the Proposed and Alternative Power Sources</b>			
<b>Fuel/Emission Type</b>	<b>Proposed Gas-Fired Steam Turbine Design</b>	<b>Onsite Power Generation Alternative</b>	<b>Purchased Power Alternative</b>
Total fuel required (MBTU/hr higher heating value)	6,674	6,834	8,359
Total CO <sub>2</sub> emissions (kTon/yr)	3,359	3,439	4,662
<b>Abbreviations:</b>			
MBTU/hr =1,000 British thermal units per hour		kTon/yr = kilotons per year	

### **3.6 ALTERNATIVE PIPELINE ROUTES**

The proposed Golden Pass Pipeline route would be within or parallel and adjacent to the existing Golden Pass Pipeline right-of-way for its entire length, and would be offset from the existing pipeline by 25 feet, where feasible. This would limit environmental impacts. We did not identify any environmental concerns that require the need to identify and evaluate alternative pipeline routes to minimize impacts, nor were any alternatives suggested during the public scoping period. Therefore, we conclude that the proposed pipeline route is the preferred alternative.

### **3.7 ALTERNATIVE PIPELINE EXPANSION ABOVEGROUND FACILITY SITES**

We evaluated alternative sites for the proposed compressor stations and also considered the need to evaluate potential alternative sites for other aboveground facilities associated with the Pipeline Expansion. Our assessments considered information obtained from inspection of maps and aerial photography and from observations during site visits.

#### **3.7.1 Compressor Station Site Alternatives**

We assessed alternative compressor station sites based on consideration of the following: (1) compression requirements (to minimize fuel consumption and reduce air emissions); (2) distance from the nearest Noise Sensitive Areas (NSA); (3) use of upland areas to minimize impacts on wetlands; (4) impacts on cultural resources or eligible historic properties; (5) presence of known contamination due to industrial activities; (6) presence of natural visual screening; and (7) accessibility.

##### **3.7.1.1 MP 1 Compressor Station**

The MP 1 Compressor Station was sited near the NGPL Interconnection to efficiently receive gas from the NGPL pipeline with a minimum of infrastructure. The proposed site is on an abandoned well pad within the existing Golden Pass Import Terminal property boundary. Any alternative site considered for this compressor station would result in placing the MP 1 Compressor Station outside of the existing terminal's storm protection levee system, which would expose the compression equipment to flooding during storm events or require an expansion of the storm protection levee. The proposed site is about 0.4 mile from the nearest NSA and the J. D. Murphree Wildlife Management Area (WMA); alternative sites along the NGPL pipeline route would site the compressor station closer to the NSA and the WMA, with one site about 0.1 mile from both. Based on the above, no alternative site considered for the MP 1 Compressor Station offers a significant environmental advantage to the proposed site, and we did not further consider them.

##### **3.7.1.2 MP 33 Compressor Station**

The proposed location for the MP 33 Compressor Station is on land owned by Golden Pass in the immediate vicinity of the north side of the existing Texoma Interconnection facilities and its mainline compressor station. The proposed site is on a parcel that contains two impoundment areas and is bracketed by wetlands, pipeline right-of-way easements, a road, and a single residence. The impoundment areas would be avoided during construction and operation, and the proposed configuration for the MP 33 Compressor Station would affect about 0.3 acre of wetlands.

Potential alternative sites for the MP 33 Compressor Station were identified west and southwest of the Texoma Interconnection facility (see figure 3.7-1). The alternative site west of the Texoma Interconnection (Alternative Site 1) would affect substantially more wetland acreage (6.3 acres) than the proposed compressor station location. In addition, locating the MP 33 Compressor Station and the Texoma Compressor Station near each other could markedly degrade local air quality due to prevailing winds. Alternative Site 2, southwest of the Texoma Interconnection, does not have sufficient area available because of the presence of multiple foreign pipelines. Further, that site would affect substantially more wetland acreage (3.8 acres) than the proposed location. As a result of these considerations, neither of the two alternative sites identified for the MP 33 Compressor Station offer a significant environmental advantage over the proposed site, and we did not further consider them.

### **3.7.1.3 MP 66 Compressor Station**

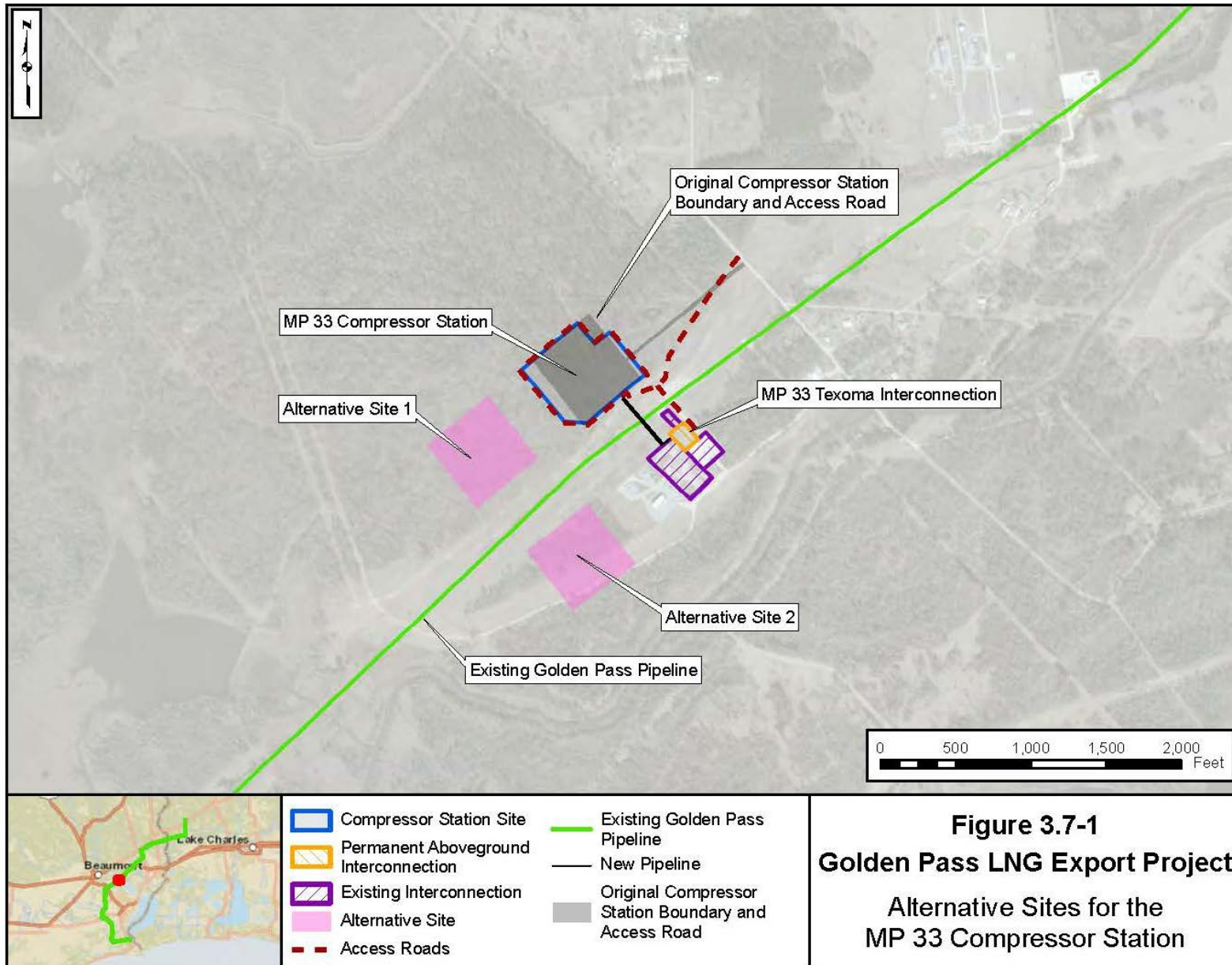
The proposed location of the MP 66 Compressor Station is on land owned by Golden Pass, immediately northwest of the existing TETCO Interconnection facilities. The area is rural and the site was previously harvested for timber. The land immediately adjacent to the proposed location consists of pipeline right-of-way, an access road, and active silviculture land. The proposed configuration for the MP 66 Compressor Station would affect about 0.1 acre of wetlands.

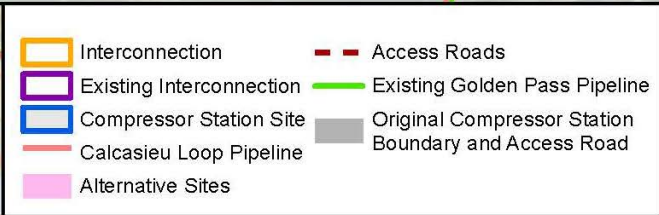
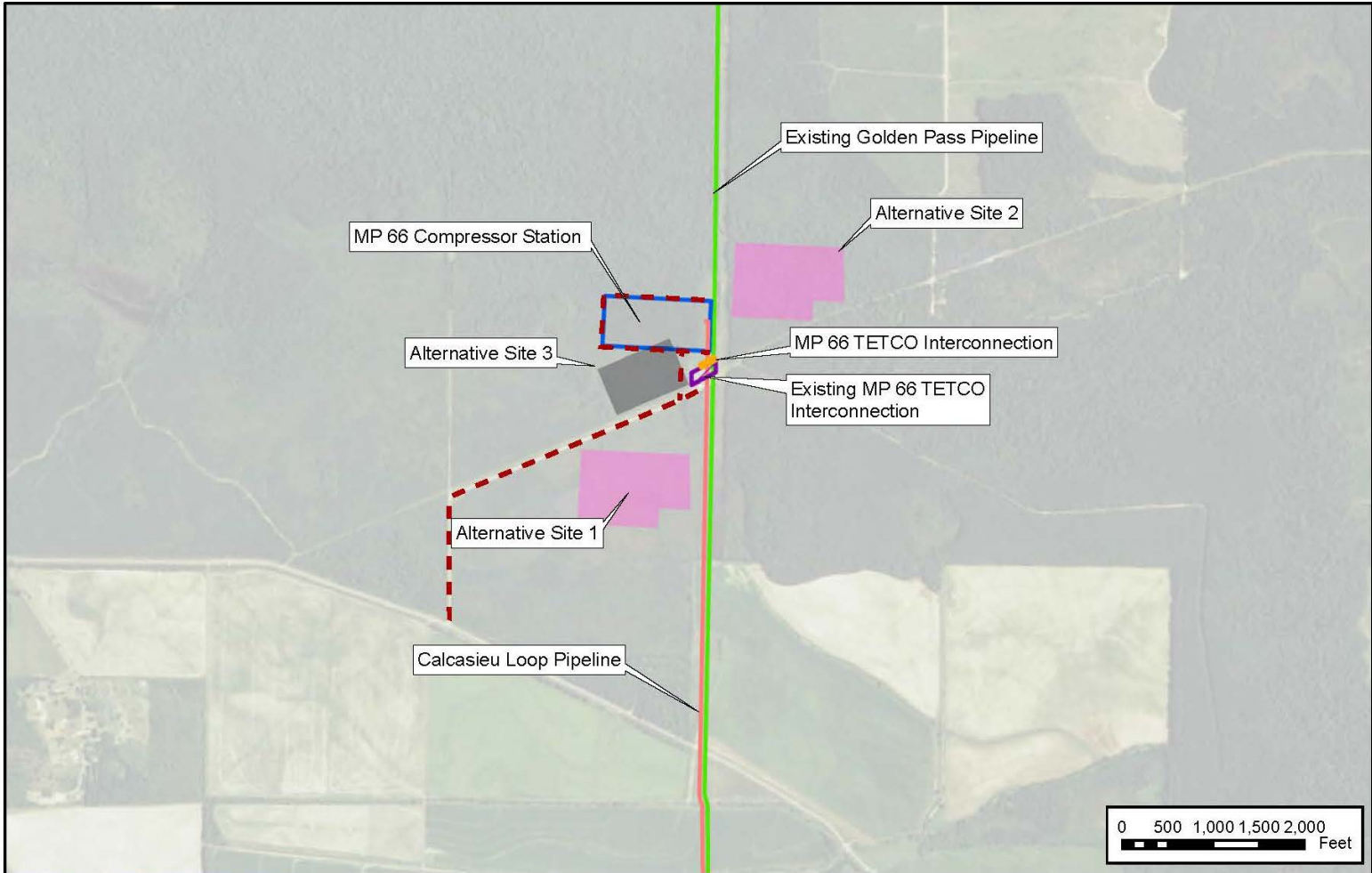
We evaluated three alternative sites for the MP 66 Compressor Station in the immediate vicinity of the TETCO Interconnection facility (see figure 3.7-2). The entire 21.2 acres of Alternative Site 1 (south of the TETCO Interconnection) is contained on upland agricultural land. Alternative Site 2, (east of the TETCO Interconnection) consists predominantly of forest wetland; siting the MP 66 Compressor Station there would affect about 5.9 acres of wetlands. Alternative Site 3 and the associated access road would affect about 3.1 acres of wetlands. Alternative Sites 2 and 3 considered for the MP 66 Compressor Station impact more wetlands than the proposed site and therefore do not offer a significant environmental advantage over the proposed site. Alternative Site 1, while impacting fewer wetlands, would not offer a significant environmental advantage after consideration of our recommendations in sections 4.3.2.1 and 4.4.2.2.

### **3.7.2 Other Aboveground Facilities**

Other aboveground facilities associated with the Pipeline Expansion include interconnections with the NGPL, Texoma, Tennessee Gas, TETCO, and Transco pipelines. The locations of these interconnections are constrained because the locations of the existing pipelines dictate their locations. During Project design, Golden Pass considered the alternatives of establishing interconnections with other pipeline systems but determined those systems to be unviable because of their relatively low available volumes or limited capacity. For example, Golden Pass considered using the Tejas and FGT pipelines as supply sources and establishing aboveground interconnections with those systems; however, neither pipeline system has sufficient volumes of natural gas available to meet the needs of the Terminal Expansion. Although the existing Golden Triangle Storage system is capable of both receiving and supplying gas and already has an interconnection with the existing Golden Pass Pipeline (MP 28), the interconnection is currently limited to a capacity of 0.25 bcf/d and is associated with a peaking facility; therefore, it could not be a long-term supply source for the Project.

All of the Pipeline Expansion interconnections would be within existing natural gas pipeline rights-of-way. We did not identify any environmental concerns that indicated the need to identify and evaluate alternative sites for the interconnections, nor were any alternatives suggested during the public scoping period.





**Figure 3.7-2**  
**Golden Pass LNG Export Project**  
Alternative Sites for the  
MP 66 Compressor Station

### **3.8 ALTERNATIVE SITES FOR THE PIPE STORAGE AND CONTRACTOR YARD**

The proposed site of the pipe storage and contractor yard is in Orange County, Texas, about 6 miles northeast of MP 33 and about 2 miles west of the City of Orangefield. This site includes 13.0 acres of industrial land that was previously disturbed and graveled during construction of the existing Golden Pass Pipeline. Use of the site would not affect any wetlands.

Golden Pass considered an alternative site about 8 miles northeast of MP 33. That site consists of about 0.8 acre of industrial/commercial land and 44.5 acres of agricultural land. Although that site also was used as a pipe storage and contractor yard during construction of the existing Golden Pass Pipeline, the agricultural land would need to be re-disturbed to be used for the Pipeline Expansion. As a result, the alternative site does not offer a significant environmental advantage over the proposed site. Therefore, we conclude that the preferred site is the proposed site of the pipe storage and contractor yard.

### **3.9 ALTERNATIVE COMPRESSOR STATION DESIGN**

#### **3.9.1 Use of Electric-Powered Compressors and Purchased Power**

Golden Pass considered the use of electric-powered compressors and purchased power as an alternative to the proposed gas-fired compressors. Although the horsepower requirements would be similar for electric-powered compressors and natural gas-fired turbines, the use of electric-powered compressors would require routing high-voltage electrical transmission lines through wetlands to reach the compressor stations. To ensure power reliability, two electrical transmission lines from separate electrical power subsystems would be required for each compressor station (in case one subsystem were to shut down) or one electrical transmission line paired with an emergency generator and storage facilities for diesel fuel. In considering the use of two electrical transmission lines to each compressor station, the lengths of the transmission lines necessary to reach the two subsystems that would likely be used for the MP 33 Compressor Station would be about 0.2 mile and about 0.8 mile, respectively. The lengths of the transmission lines necessary to reach the subsystems that would likely be used for the MP 66 Compressor Station would be about 2.7 miles and 10.8 miles, respectively. Using electrical power also would require additional infrastructure at the compressor station locations, as each compressor station would require a substation and/or switching station to reduce the high-voltage power from the electrical lines to a level usable by the compressor stations. Construction of either one or two distribution lines to the compressor stations would increase land affected by the Project and add to visual impacts.

The electrical power supplied by the grid could be provided by several electrical generation plants and, therefore, a variety of fuels could be used. As a result, the increase in emissions from the generation plants due to providing electrical power to the compressor stations would be difficult to calculate. Golden Pass provided estimated greenhouse gas (GHG) emissions from power plants (93,000 mtpy for the MP 33 Compressor Station and 478,000 mtpy for the MP 66 Compressor Station) and the proposed gas-driven compressors (87,000 mtpy for the MP 33 Compressor Station and 470,000 for the MP 66 Compressor Station). The estimates indicate that emissions associated with purchased power would average about 4 percent higher than those of the proposed gas-driven compressors. However, with the large number of variables in the estimates, and with current emission control technology and the air permit requirements that the generation plants and the compressor stations must comply with, we anticipate that there would not be a substantial difference in the GHG and other emissions between the two alternative methods of providing power to the compressor stations.

Because additional environmental disturbance would result from construction of the electrical transmission lines and emissions for each alternative would likely be similar, the use of purchased electric power for operating the compressor stations would not offer a significant environmental advantage over the proposed natural gas-fired compressors. Therefore, we conclude that the proposed use of gas-fired compressors is the preferred alternative.

## **4.0 ENVIRONMENTAL IMPACT ANALYSIS**

The environmental consequence of constructing and operating the Project would vary in duration and significance. Four levels of impact duration were considered: temporary, short term, long term, and permanent. A temporary impact generally would occur during construction, with the resource returning to pre-construction conditions almost immediately afterward. A short-term impact could continue for up to 3 years following construction. An impact was considered long term if the resource would require more than 3 years to recover. A permanent impact could occur as a result of an activity that modifies a resource to the extent that it would not return to pre-construction conditions during the life of the Project, such as the construction and operational impact of a compressor station. We considered an impact to be significant if it would result in a substantial beneficial or adverse change in the physical environment and the relationship of people with the environment.

In this section, we discuss the affected environment, general construction and operational impacts, and proposed mitigation measures for each resource. We also discuss the design and construction of the facility to resist natural hazards. The applicant, as part of its proposal, agreed to implement certain measures to reduce impacts on environmental resources. We evaluated the proposed mitigation measures to determine whether additional measures would be necessary to reduce impacts. Where we identified the need for additional mitigation, the measures appear as bulleted, boldfaced paragraphs in the text. We will recommend that these measures be included as specific conditions to authorizations that the Commission may issue to Golden Pass. Conclusions in this EIS are based on our analysis of the environmental impact and the following assumptions:

- Golden Pass would comply with all applicable federal laws and regulations.
- The proposed facilities would be constructed as described in section 2.0 of this document.
- Golden Pass would implement the mitigation measures included in its application and supplemental filings to the FERC.

## **4.1 GEOLOGIC CONDITIONS, RESOURCES, HAZARDS, AND MITIGATION DESIGN MEASURES**

### **4.1.1 Geologic Setting**

The Project lies within the Gulf Coastal Plain geomorphic province and is immediately underlain by sediments deposited during the Holocene and Pleistocene epochs of the Quaternary period. The Project would cross the Coastal Prairie sub-province in Jefferson and Orange Counties, Texas. This sub-province is composed of Holocene alluvium of sands, silts, and clays that have eroded to form subtle slopes to the southeast. Within Calcasieu Parish, Louisiana, the Pipeline Expansion would cross the Pleistocene-aged Prairie and Montgomery terraces of the West Gulf Coastal Plain, which consists of alluvial Holocene sediments as well as sand, silt, and clay of the Beaumont and Lissie Formations (USGS, 2003). Figure 4.1-1 is a detailed map of geologic resources in the vicinity of the proposed Project.





#### **4.1.1.1 Terminal Expansion**

All of the Terminal Expansion facilities lie within Holocene alluvium deposits, composed of clay, silt, and sand. The proposed expanded terminal access road crosses the Holocene alluvium deposits as well as the Holocene Barrier Ridge and Barrier Flat deposits, composed of sand, silt, and clay. The Terminal Expansion facilities would be placed in a designated disposal area for dredge spoil material. The site is flat to gently sloping. Fugro (2014a, 2015b) conducted soils borings in the proposed Project area and identified the general stratigraphy of the site. The average site grade exists at two levels within the site: the upper level ranges between +6 and +10 feet above mean sea level (MSL), and the lower level is approximately +2 feet above MSL. The general subsurface stratigraphy at the site is characterized by three layers. An upper layer from depths of 0 to -8 to -12 feet below MSL is very soft to soft clay with pockets of sand, from depths of -8 to -12 to -80 feet below MSL is soft to firm clays with sandy silt layers, and the layer from depths of -80 to -200 feet below MSL is clay with clayey silt and silt clay ranging from stiff to very stiff. The geotechnical studies suggest that neither outcrops nor near-surface expressions of bedrock, including shallow salt domes, are present at the site. Therefore, Golden Pass would not conduct blasting during construction.

#### **4.1.1.2 Pipeline Expansion**

The Calcasieu Loop generally would lie within sediments of the late Pleistocene Beaumont Formation and Holocene alluvium deposits, which consist of clay, silt, and sand (USGS, 2005). The MP 1 Compressor Station and access road also would lie within the Holocene alluvium deposits. The MP 33 Compressor Station, the Texoma Interconnect, and the access road would lie within two formations. The Holocene Deweyville Formation consists of sand, silt, clay, and gravel and is locally inundated with calcium carbonate. The Pleistocene Beaumont Formation contains clay and silt mixed with beds of sand. The TGP Interconnect, the MP 66 Compressor Station, the TETCO Interconnect, and associated access roads also would be within the Pleistocene Beaumont Formation. The Transco Interconnect and access road would lie within the Pleistocene Lissie Formation, which includes light-gray to brown clay, sandy clay, and silt, with sand and gravel. Average site elevations at the aboveground facilities would range from a low of +5 feet above MSL at the NGPL Interconnect and the MP 1 Compressor Station to +47 feet above MSL at the Transco Interconnect. The average elevation of the other pipeline expansion facilities would be between +18 and +29 feet above MSL.

The proposed pipe storage and contractor yard and access roads would be within the late Pleistocene Beaumont Formation, which consists of unconsolidated coarse-detrital sand, fine-detrital silt, and fine-detrital clay (USGS, 2005).

#### **4.1.2 Mineral Resources**

Exploitable mineral resources in the vicinity of the Project include oil and gas, salt, sulfur, sand, gravel, and clay (FERC, 2005). However, only gas and sand operations were identified in the immediate area.

##### **4.1.2.1 Terminal Expansion**

One gas well (API 245-32321) is within a 0.25 mile radius of the Terminal Expansion; this well was plugged and abandoned in 2009. The well would be on the Terminal Expansion property at the MP 1 Compressor Station site. Two abandoned sand borrow pits are within about 0.5 mile of the expanded terminal facilities. Both appear to have been inactive since at least 1998 and currently are filled with water. One sand pit is less than 500 feet southwest of the Terminal Expansion site, and the second pit is about 1,000 feet west of the Terminal Expansion site. No known or planned mines are within the vicinity of the proposed Terminal Expansion site. Nine natural gas pipelines and one crude oil line are within 0.25 mile

of the site. Six of these pipelines run through or across the Terminal Expansion site. These lines would not be disturbed during construction or operation of the Project. Therefore, we conclude that the Terminal Expansion would not affect mining or oil and gas activities.

#### 4.1.2.2 Pipeline Expansion

Potentially exploitable mineral resources that are known to occur within the general vicinity of the pipeline route and aboveground facilities include salt (salt domes), construction-grade sand and gravel, and crushed stone. No oil and gas wells or production areas, borrow pits, or mines are within 0.25 mile of the Pipeline Expansion. A total of 64 foreign pipelines would be crossed by, or in proximity to, the Pipeline Expansion facilities (see table 4.1-1). These lines would not be disturbed during construction or operation of the Project. Therefore, we conclude that the Pipeline Expansion would not affect mining or oil and gas activities.

Project Component	Commodity					Number of Lines Crossed by the Project
	Natural Gas	Crude	Carbon Dioxide	Gasoline/Fuel	Natural Gas Liquids	
MP 1 Compressor Station & NGL Interconnect	7	1	0	0	0	3
MP 33 Compressor Station & Texoma Interconnect	25	0	1	1	8	15
Calcasieu Loop (MP 63 – MP 66)	6	0	0	0	0	5
TGP Interconnect (MP 63)	4	0	0	0	0	3
MP 66 Compressor Station & TETCO Interconnect	4	0	0	0	0	1
Transco Interconnect (MP 68)	7	0	0	0	0	1
Note: "Foreign" pipelines are existing pipelines that are not part of the Golden Pass Pipeline system.						

#### 4.1.3 Geologic Hazards

“Geologic hazards” are defined by the American Geological Institute as “geologic conditions or phenomena that present a risk or are a potential danger to life and property, either naturally occurring or man-made” (Bates and Jackson, 1984). Potential geologic hazards in the vicinity of the Project include seismic ground shaking, fault offsets, soil liquefaction, slope failures/landslides, tsunamis, erosion, flooding, and ground subsidence. Neither volcanism nor karst topography occurs within the vicinity of the Project, and these geologic hazards were excluded from further consideration.

#### 4.1.3.1 Geotechnical Site Characterization

A pre-front-end-engineering-design (FEED) level geotechnical investigation was performed at the site of the Terminal Expansion facility in 2013 (Fugro, 2013). The investigation consisted of three marine soil borings to depths of 25 feet and 11 cone penetration tests (CPT) to depths of 167 to 196 feet. In addition, 68 soil borings and 52 CPTs were performed for the existing terminal in 2003/2004 and 2006 (Fugro, 2004, 2007a, 2007b). The FEED-level geotechnical investigation for the Terminal Expansion and MP 1 Compressor Station was performed between June 11 and August 23, 2014; it consisted of 20 soil borings, 6 CPTs, 7 shallow auger borings, 2 downhole seismic tests in borings SBH-73 and SBH-76, and laboratory testing on the recovered samples (Fugro, 2014a). In addition, Fugro provided a seismic study (Fugro, 2014b) and fault study (Fugro, 2014c) for the Project area.

The subsurface conditions consist of very soft to soft clay with pockets of sand from depths of 0 to -8 to -12 feet below MSL, soft to firm clays with sandy silt layers from depths of -8 to -12 to -80 feet below MSL, and clay with clayey silt and silt clay ranging from stiff to very stiff from depths of -80 to -200 feet below MSL.

The Terminal Expansion site would be cleared, graded, and filled to achieve a general site grade of from +3 to +8 feet elevation. Because of the presence of very soft, compressible soils, Golden Pass would support all settlement-sensitive structures on deep foundations. Lightly loaded structures or equipment insensitive to settlement may be supported on concrete pads.

Golden Pass indicated that no site-specific geotechnical investigations were completed for the MP 33 and MP 66 Compressor Stations. Golden Pass stated that geotechnical surveys would be completed prior to finalizing the engineering designs at these two compressor station sites. Because these studies have not been provided, **we recommend that:**

- **Prior to construction, Golden Pass should file with the Secretary of the Commission (Secretary) the results of geotechnical studies for the MP 33 and MP 66 Compressor Stations.**

#### 4.1.3.2 Seismic Ground Shaking Hazards

The Project site is within the seismotectonic setting known as the Texas Gulf Coastal Plains region. Tertiary and Quaternary structures in the Texas Gulf Coastal Plains are related to the tectonic environment of the Gulf of Mexico passive margin. Growth faults and faults associated with salt domes trend parallel to the Louisiana and Texas coastlines. They formed during a period of accelerated basin subsidence, but movement along these features is related to a gradual creep as opposed to sudden seismic events. Earthquakes have not been linked to these growth fault systems (Stevenson and McCulloh, 2001).

##### **Terminal Expansion**

Golden Pass conducted a seismic hazard analysis during the environmental review for the existing terminal. No active or dormant surface faults were found in the vicinity of the site and earthquake hazards were not a controlling factor in the facility design (ABSC, 2004).

The Terminal Expansion site is in an area of low seismicity. Only a few earthquakes have been recorded in the Project area, and they have occurred infrequently. The most recently documented earthquakes in this area include a 3.3-magnitude quake near Orange, Texas, in 1952 and a 3.8-magnitude quake near Lake Charles, Louisiana, in 1983 (University of Texas, 2014; Stevenson and McCulloh, 2001). The most significant seismic source site is the New Madrid Seismic Zone, which is about 500 miles northeast from the liquefaction facility in the vicinity of New Madrid, Missouri. In 1811 and 1812, this

seismic zone experienced three very large earthquakes, with magnitudes estimated to range between 7.2 and 7.6.

For the Terminal Expansion site, the peak ground accelerations on a rock site are in the range of 1 to 2 percent of the acceleration of gravity (0.01 to 0.02 g), for a 10-percent probability of exceedance in 50 years (475-year return period and 0.02 to 0.06 g for a 2-percent probability of being exceeded in 50 years) (USGS, 2013). The USGS-estimated rock ground accelerations are relatively low compared to other locations in the United States. Peak ground accelerations on rock sites can be amplified by factors of two or more on soft soil sites, which are typical of those in the vicinity of the Project. Because the proposed facilities would be designed for earthquake ground motions, it is unlikely that they would be affected if an earthquake were to take place. The seismic design of the Project's Seismic Category I items are to be based on site-specific Safe Shutdown Earthquake (SSE) and Operating Basis Earthquake (OBE) ground motions developed by Fugro (2014b). The site-specific SSE is a ground motion with a 2-percent probability of exceedance in 50 years, while the OBE has a 10-percent probability of exceedance in 50 years.

The Terminal Expansion would be constructed to satisfy the design requirements of 49 CFR 193, NFPA 59A (2001), and American Society of Civil Engineers (ASCE) 7-05. For seismic design, the facility also would be designed to satisfy the requirements of NFPA 59A (2006) and ASCE 7-05.

Therefore, we conclude that only a minimal overall hazard would be associated with seismicity at the Terminal Expansion facilities.

### **Pipeline Expansion**

USGS Seismic Hazard Maps addressing the areas of the Calcasieu Loop and aboveground facilities indicate that, for a rock site, peak ground accelerations of 2 to 4 percent of the acceleration of gravity (0.02 to 0.04 g) have a 2 percent probability of exceedance in 50 years (USGS, 2014). These peak ground accelerations increase when site amplification effects (such as surface topography and sediments at the site) are considered. Even with this amplification, however, the seismic hazard risk along the proposed route is considered to be relatively low compared to other locations in the United States.

Therefore, we conclude that only a minimal overall hazard would be associated with seismicity and faulting along the Pipeline Expansion facilities.

#### **4.1.3.3 Surface Faulting**

### **Terminal Expansion**

As part of their geotechnical and seismic hazard studies, Fugro performed a geologic fault study to assess the possibility of surface faulting that could affect the Terminal Expansion site (Fugro, 2014c). In the study, several fault identification techniques were used because the validity of the findings from individual methods varies. All techniques gave no credible indications of the presence of a fault that might affect the Terminal Expansion site (Fugro, 2014c).

### **Pipeline Expansion**

Surface faulting is not expected to be present along the Pipeline Expansion; therefore, there would be no impacts on the pipeline or aboveground facilities.

#### **4.1.3.4 Soil Liquefaction**

Soil liquefaction occurs when a saturated soil loses its load-bearing capability through an increase in pore water pressure resulting from seismic ground shaking. Saturated sandy soils with low silt and clay content are susceptible to soil liquefaction during seismic events.

##### **Terminal Expansion**

Golden Pass performed a liquefaction triggering assessment with regard to soils for the Terminal Expansion site (Fugro, 2014b). While the 1- to 2-foot-thick silty sand layers near the surface (less than -25 feet below MSL) could liquefy if submerged, they are too thin to liquefy and are not continuous. In addition, cohesionless layers at deeper depths would be too dense to liquefy. Liquefaction settlements were estimated to be less than 3 inches for the 2,475-year return hazard period, with the majority of the area less than 1 inch.

Because the potential for seismic ground shaking in the vicinity of the Project is low, the probability of soil liquefaction is also low. In addition, Golden Pass would address possible issues related to potential liquefaction and associated loss of strength in the fill soils by using piles in the foundation design for the Terminal Expansion facilities.

##### **Pipeline Expansion**

As the probability of soil liquefaction is low across the Project area, Golden Pass would address possible issues related to potential liquefaction and associated loss of strength in the fill soils by using piles in the foundation design for the compressor stations.

#### **4.1.3.5 Landslide Incidence and Susceptibility**

“Landslides” are defined as the movement of rock, debris, or soil down a slope (USGS, 2014). Given that the topography of the Terminal Expansion site and along the pipeline route is relatively flat, the Project has a low risk of impact caused by a landslide.

#### **4.1.3.6 Ground Subsidence**

Subsidence hazards involve the sudden collapse of the ground to form a depression or the slow subsidence or settlement of sediments near the ground’s surface. Ground subsidence in the vicinity of the Project could result from natural geologic processes or from man-made processes, such as oil and gas extraction and removal of groundwater from aquifer systems. There is a relatively low level of oil and gas production in the vicinity of the Terminal Expansion and Pipeline Expansion facilities, and the Project does not involve removal of groundwater from aquifer systems.

##### **Terminal Expansion**

Subsidence along the Texas (Houston-Galveston area) and Louisiana coasts averages approximately 0.2 to 0.5 inch per year (Gibeaut et al., 2000; Dokka et al., 2003). In addition, compaction of soft soils near the surface could result in settling. Golden Pass would place all foundations for major equipment and structures on pile foundations, which would be designed in accordance with NFPA 59A (2001) and, where applicable, the more stringent requirements of NFPA 59A (2006). Although subsidence is anticipated, the design of the Terminal Expansion would minimize any subsidence effects during operation (e.g., pile-supported foundations).

## **Pipeline Expansion**

All of the compressor stations would be installed on pile foundations. In addition, the storm protection levee surrounding the MP 1 Compressor Station would be maintained to prevent effects of subsidence. As a result of minimal subsidence hazards near the Pipeline Expansion facilities and installation of foundation piles at the compressor stations, the Project has a low risk of impacts caused by subsidence.

### **4.1.4 Other Hazards**

#### **4.1.4.1 Flooding/Storm Surge/Tsunami**

A flood occurs when the water level in a stream or river channel overflows the natural or man-made bank. Storm surge from tropical cyclones and tsunamis also can cause flooding. There are no records of tsunamis in the vicinity of the Project (Fugro, 2014c). Storm surge is a coastal phenomenon associated with low-pressure weather systems, typically intense hurricanes, and winter storms. The surge of ocean water inland above the high tide mark is a result of low barometric pressure combined with high winds pushing on the ocean surface, causing the water to “pile up” higher than ordinary sea level. The storm surge effect is enhanced if it occurs at high tide (NOAA, 2014a).

Flash floods typically result from intense rapid precipitation in upstream areas that leads to extensive short-duration runoff into the stream channel. The 100-year flood represents a river channel water level that, based on an analysis of the historical record, is likely to be equaled or exceeded every 100 years—meaning that there is a 1 percent chance that the water level will be equaled or exceeded in any individual year during a century. The 100-year flood is generally used for planning purposes for building within a floodplain to assess the likelihood of inundation over time.

## **Terminal Expansion**

The Terminal Expansion site is within the Federal Emergency Management Agency’s (FEMA) Flood Hazard Zone A, which is susceptible to coastal flooding (FEMA, 2013). Since 1996, Jefferson County, Texas has experienced wind and/or flooding from eight tropical cyclones, four of which were classified as hurricanes (winds greater than 74 miles per hour [mph]). In the last 20 years, six hurricanes have made landfall in the general vicinity of Port Arthur, Texas (NOAA, 2013a), with three coming ashore since 2005. Hurricane Rita made landfall in 2005 between Sabine Pass, Texas and Johnson’s Bayou, Louisiana; winds were 120 mph, and the storm tide about 3 miles south of the Terminal reached 8.12 feet (NOAA, 2005; LSU, 2013). In 2007, Hurricane Humberto came ashore on the east side of Galveston Bay; winds reached 92 mph (NOAA, 2013b), and the reported storm tide was 4.1 feet (LSU, 2013). In 2008, Hurricane Ike made landfall east of Houston and continued northwest; wind gusts at Port Arthur were 106 mph and the storm tide about 3 miles south of the Terminal was about 14.5 feet (NOAA, 2009; LSU, 2013).

Golden Pass used NOAA’s Sea, Lake, and Overland Surges (SLOSH) hydrodynamic model for Category 1 through 5 hurricanes to predict storm surge elevations. The model results showed the required levee crest elevation to be the planned elevation for the 1-percent annual exceedance event. The entire Terminal Expansion would be enclosed for flood protection by construction of the new levee system, which would have a crest of 16 feet NAVD 88. The 16-foot height would provide additional freeboard well over the 100-year storm surge. The levee would have a 10-foot-wide crest and a 2.5:1 slope; it would be lined with rip-rap on the side facing the SNWW. A stormwater management system already is in place at the site to route and discharge water. Design factors regarding wind are discussed in section 4.12.1.

Fugro’s Site Specific Seismic Hazard Assessment report (Fugro, 2014c) evaluated the potential for a tsunami or seiche (i.e., a condition in which a body of water is caused to rock, causing wave action) to

affect the liquefaction facility. The Terminal Expansion site is about 5 miles north of the Gulf of Mexico shoreline. Given the low probability of strong seismic events in the Gulf; the report concluded that the seismically generated tsunami or seiche hazard does not represent a significant inundation hazard to the Gulf Coast (Fugro, 2014c). Tsunamis also could be generated by offshore landslides. Because the maximum estimated run-up values for tsunamis are significantly less than those from storm surge and the facility is designed for storm surge, the tsunami hazard is inherently considered in the facility design. We concur with this determination.

### **Pipeline Expansion**

Extreme storm events can lead to flood hazards along the Pipeline Expansion corridor, particularly along river floodplains and in low-lying areas. The portion of the pipeline in Jefferson County, Texas, near the Terminal Expansion site (MP 1 Compressor Station and interconnect) would be within a FEMA-designated Flood Hazard Zone A. Buried pipelines are rarely affected by flooding; however, Golden Pass would use concrete-coated pipe to weight the pipe in wet areas. The pipeline right-of-way would be regularly inspected to identify erosion or exposed pipe.

Some aboveground facilities associated with the Pipeline Expansion would be within flood zones. Pipeline facilities in Orange County, Texas (MP 33 Compressor Station and interconnect), would not be within a designated 100-year floodplain. Pipeline facilities in Calcasieu Parish, Louisiana (Calcasieu Loop, MP 66 Compressor Station and interconnect), would be within Flood Hazard Zone A; the Transco Interconnect at MP 68.5 would not be within a 100-year floodplain (FEMA, 2013).

Golden Pass would construct aboveground facilities, such as the modified interconnections and metering and regulating stations at sufficient elevations to minimize flooding or surround them with a storm protection levee. The MP 1 Compressor Station would be within the Terminal Expansion storm protection levee. The MP 33 Compressor Station would be a minimum of 2 feet above the 100-year flood zone. The MP 66 Compressor Station would be within the 100-year flood zone, but all equipment foundations would be raised a minimum of 2 feet above that elevation. As a result, we believe that the Pipeline Expansion facilities would not be affected by flooding or storm surge.

#### **4.1.4.2 Shoreline Erosion and Localized Scour**

Shoreline erosion occurs when waves, shoreline currents, and vessel wakes disturb shoreline soils and mobilized soil is transported from the site. Irregular or changing stream channel morphology, often related to man-made structures or stream channel debris, can lead to scouring of channel bottom materials during periods of high water flow. Water vortices can develop in deep scour holes.

### **Terminal Expansion**

Shoreline erosion could occur at the Terminal Expansion site and along the shoreline of the SNWW from waves, currents, and the wake of large vessels transiting the channel. The State of Texas designated the western shoreline immediately north of the facility as a critical erosion area (TGLO, 2013). As part of construction of the existing terminal (2005 to 2010), about 2 acres of shoreline were reclaimed using 24,000 yd<sup>3</sup> of imported fill. In addition, a revetment system was installed along the slopes of the Ship Slip, and the shoreline slopes of the marine basin were armored. As part of the Terminal Expansion, the existing shoreline protection system would be expanded and areas of the existing protection system would be upgraded and/or retrofitted. About 1,400 feet of new rock revetment would be added west of the existing Ship Slip, and about 4,100 feet of new revetment would be added east of the existing Ship Slip along the access channel. In addition, about 4,100 feet of new revetment would be added on either side of the Supply Dock. The revetment would consist of an approximately 4-foot-thick stone armor layer, 18-inch-thick stone



bedding layer, and geotextile fabric. Even though shoreline erosion is prevalent at this location, Golden Pass' proposed mitigation measures would minimize erosion and scour impacts.

### **Pipeline Expansion**

The Pipeline Expansion facilities would not be located directly on the coast or along a major waterbody; therefore, the facilities would not be subjected to direct effects from shoreline erosion. The pipeline route would cross a single minor waterbody, an agricultural ditch, as discussed in section 4.3.2.

#### **4.1.5 Paleontology**

While fossils in the region are generally rare, there have been occasional discoveries of fossil remains of animals such as camels and mastodons. Holocene and Pleistocene marine fossil fragments are sometimes found within sedimentary units deposited in these epochs, but these fragments have little scientific value. No known paleontological resources are in the Project vicinity (Fossilworks, 2013; Westgate, 2004). If any paleontological resources are discovered during construction, they would be treated in accordance with Golden Pass' *Unanticipated Discovery Plan* (UDP) (see appendix D). We have reviewed Golden Pass' UDP and find it acceptable.

#### **4.1.6 Design and Construction of the Golden Pass LNG Liquefaction Facility**

##### **4.1.6.1 Site Grading**

The liquefaction facility site would be cleared, grubbed, and prepared using standard earthmoving and compaction equipment. Stripping consists of excavation, removal, and satisfactory disposal of all topsoil and soil containing organic material. The average depth of stripping is estimated at 3 inches. The Terminal Expansion and construction sites would be enclosed within a storm surge barrier berm with a High Point Finished Surface crest elevation of + 16 feet NAVD 88 that matches the elevation of the existing storm surge barrier berm. The final finish grades of the terminal would consist of three different elevations after cut-and-fill operations have been completed. The first area would be the High Point Finish Surface + 3 NAVD 88 and hold the construction area south; the second would be the High Point Finish Surface + 5 feet NAVD 88 and includes the process and the construction area north; and the third zone would be the Admin/Warehouse area, located west of the existing terminal, that would be at High Point Finish Surface + 8 feet NAVD 88.

##### **4.1.6.2 Foundations**

Golden Pass currently plans to support all structures and equipment foundations in the Project area on 18-inch driven precast square pile foundations or 24-inch open-ended steel pipe piles. Lightly loaded structures or equipment insensitive to settlement may be supported on concrete pads.

##### **4.1.6.3 Facility and Structure Design**

The liquefaction facilities would be constructed to satisfy the design requirements of 49 CFR 193, NFPA 59A (2001), the 2009 International Building Code, and ASCE 7-05. For seismic design, the facility would be designed to satisfy the requirements of NFPA 59A (2001), applicable portions of NFPA 59A (2006), and ASCE 7-05.

### **Wind Design**

LNG facilities, as defined in 49 CFR 193, would be designed for a sustained wind speed of 150 mph, which is equivalent to a 183-mph, 3-second gust wind speed. Other facilities would be designed

for a 145-mph, 3-second gust wind speed in accordance with ASCE 7-05. Design factors regarding wind are discussed in section 4.12.1.

### **Seismic Design Ground Motions**

Geotechnical investigations at the expanded terminal site determined that the soils at the site are soft clay. Sites with soil conditions of this type could experience significant amplifications of surface earthquake ground motions. Fugro performed a site-specific seismic hazard study for the site (Fugro, 2014b). As per ASCE 7-05, the study calculated the Maximum Considered Earthquake ground motions of the ground surface at the site with a 2 percent probability of being exceeded in 50 years. Facility components are further broken down into three categories. Class 1 includes LNG containers, systems required for isolation of LNG containers, and systems required for safe shutdown and fire protection systems. Category 2 includes facilities and systems not included in Category 1 that are needed for safe plant operation; it includes inlet facilities, pre-treatment area, power generator area, fuel gas system, interconnecting piping systems, metering systems, LNG pumps, and other items. Category 3 includes all other facilities that are not included in Categories 1 and 2; it includes administration buildings, dock service equipment, waste treatment plant, and incoming electrical power supply.

The seismic design of the Project's Seismic Category I items are to be based on site-specific SSE and OBE ground motions. The site-specific SSE is a ground motion with a 2-percent probability of exceedance in 50 years, while the OBE has a 10-percent probability of exceedance in 50 years. SSE and OBE peak ground accelerations and spectral accelerations were calculated by Fugro (2014b) and used in the design of the proposed Project facilities. Category 1 and 2 facilities would be designed in accordance with 2006 IBC seismic design criteria. The Terminal Expansion would be constructed to satisfy the design requirements of 49 CFR 193, NFPA 59A (2001), and ASCE 7-05. For seismic design, the facility also would be designed to satisfy the requirements of NFPA 59A (2006) and ASCE 7-05.

### **Submittal of Final Design Documents**

The design of the facility is currently at the FEED level of completion. Golden Pass has proposed a feasible design and has committed to conducting a significant amount of detailed design work for the proposed liquefaction facility if the Project is authorized by the Commission. Information regarding development of the final design, as detailed below, would need to be reviewed by the FERC staff in order to ensure that the final design addresses the requirements identified in the FEED. Further, the timing of the production of this information should occur prior to the stage that Golden Pass has indicated in its application and subsequent filings. Therefore, **we recommend that:**

- **Golden Pass file the following information, stamped and sealed by the professional engineer-of-record in the state of Texas, with the Secretary prior to construction:**
  - a. **site preparation drawings and specifications;**
  - b. **LNG liquefaction facility structures and foundation design drawings and calculations (including prefabricated and field constructed structures);**
  - c. **seismic specifications for procured equipment; and**
  - d. **quality control procedures to be used for civil/structural design and construction.**

**In addition, Golden Pass should file, in its *Implementation Plan*, the schedule for producing this information.**

## 4.2 SOILS

Potential impacts on soil resources during construction and operation of the Terminal Expansion and Pipeline Expansion may be associated with soil limitations, prime farmland, hydric soils, soil compaction, soil erosion, revegetation, and contamination.

### 4.2.1 Soil Types and Limitations

Soil types that occur within the Project area were identified by consulting the U.S. Department of Agriculture, Natural Resource Conservation Service (NRCS) Soil Survey Geographic Database (SSURGO) (NRCS, 2014a, 2014b) for Jefferson and Orange Counties, Texas (NRCS, 1996) and Calcasieu Parish, Louisiana (NRCS, 1988).

#### 4.2.1.1 Terminal Expansion

Four soil types are present at the Terminal Expansion site: Bancker mucky peat, Barnett mucky peat, Ijam clay, and Sabine-Baines complex. Soils within the Terminal Expansion site are aquents and aquolls. Aquents are soils that have undergone minimal weathering and have been saturated for a significant period of time. In this case, they are characterized by altered or disturbed soils where the original soil material has been removed or repositioned, or fill has been added. Aquolls are soils with a high amount of organic matter and nutrients that have been saturated for significant period of time; they often are found in coastal ridges and are derived from loamy and clayey sediments. These soils have limited agricultural use unless they are artificially drained (NRCS, 2014c).

Most areas on the Terminal Expansion site are former marshlands, where materials from COE maintenance dredging were deposited. These soils consist of a 10- to 14-foot-thick layer of fine-grained clay, silty clay, silts and clayey silts, and coarse sands to clays—sometimes with stratified layers of varying thickness (Fugro, 2004). About 368,750 yd<sup>3</sup> of clays, with layers of sandy clays and silts, would be removed during construction of the Supply Dock and access channel. Golden Pass also estimates that about 45,000 yd<sup>3</sup> of sediment would need to be removed to maintain the necessary depth at the Supply Dock and access channel. Through the 1970s, the COE used undeveloped areas along the SNWW for disposal of dredged materials. Construction of the Terminal Expansion facilities would permanently affect more than 95 percent of aquents soils and less than 5 percent of aquolls soils.

To minimize impacts on soils, Golden Pass would construct and restore the Terminal Expansion in accordance with FERC's Plan, which includes erosion and sedimentation control measures, and provisions for restoration and revegetation. In addition, Golden Pass has developed a *Dredged Material Management Plan* (DMMP) to address the excavation and disposal of material related to construction of the Supply Dock, temporary float channels, and access channel. Currently, Golden Pass is exploring three potential DMPA along the SNWW and within 6 nautical miles of the Terminal Expansion site for disposal of dredged material from the Supply Dock, temporary float channels, and access channel. These sites, currently used by the COE and the Sabine Neches Navigation District (SNND), are upland areas with levees and weir structures to allow water to flow out as the dredged sediments settle. Golden Pass considered and eliminated disposal of dredged material at the J. D. Murphree WMA (Golden Pass would dispose of dredge spoil from the existing Ship Slip at this location for wetland mitigation [see section 4.4]), disposal at several ocean dredged material disposal sites, and reuse of the dredged material. These alternatives were eliminated because of incompatibility of sediment types at the WMA and ocean dredged material disposal sites and because of cost and space to dewater dredged material for reuse. According to Golden Pass, about 22,000 yd<sup>3</sup> of dredged material would be reused to construct storm berms.

#### **4.2.1.2 Pipeline Expansion**

Four soil types would be crossed by the Calcasieu Loop: Brimstone silt loam, Guyton silt loam, Guyton-Messer silt loams complex, and Kinder-Messer silt loams complex. These four soil types are Alfisols and part of either the aqualf or udalf suborder. Aqualfs are moderately weathered soils that have undergone a significant period of saturation. They occur low in the landscape on floodplains, broad flats, or depressions. Udalfs are moderately weathered soils with seasonal moisture availability (NRCS, 2014a, 2014b).

Eight soil types would be crossed by the compressor stations and interconnects: Bancker mucky peat, Camptown silt loam, Orcadia-Anahuac complex, Texla-Evadale complex, Orcadia-Aris complex, Guyton silt loam, Guyton-Messer silt loams complex, and Kinder-Messer silt loams complex. With the exception of the Bancker mucky peat series, the other seven soils crossed by the aboveground facilities are either aqualfs or udalfs. The Bancker mucky peat series is classified as an aquent. Three soil types would be crossed by the access roads: Guyton silt loam, Kinder-Messer silt loams complex, and Bancker mucky peat.

To minimize impacts on soils, Golden Pass would construct and restore the Pipeline Expansion in accordance with FERC's Plan, which includes provisions for erosion control, restoration, revegetation, and special construction techniques for saturated soils and agricultural areas.

#### **4.2.2 Prime Farmland Soils**

Prime farmland soils have the best combination of physical and chemical characteristics for producing food, feed, forage, fiber, and oilseed crops (NRCS, 2012a). It is a special classification that receives special protections under the Federal Surface Mining Control and Reclamation Act of 1977. In general, prime farmland soils have adequate and dependable precipitation, a favorable temperature and growing season, acceptable acidity or alkalinity, and few or no surface stones. They are permeable to water and air. Prime farmland soils are not excessively erodible or saturated with water for long periods of time.

##### **4.2.2.1 Terminal Expansion**

There are no prime farmland soils on the Terminal Expansion site (see appendix E). Therefore, there would be no impacts on prime farmland soils in this area.

##### **4.2.2.2 Pipeline Expansion**

About 1.4 miles of the Calcasieu Loop (48 percent) contain prime farmland soils, but the HDD method, not trenching, would be used for about 0.6 mile of these soils. Construction of the pipeline would affect 9.7 acres of prime farmland soils, and operation would affect 6.3 acres of prime farmland. Construction of the compressor stations and other aboveground facilities would temporarily affect 37.7 acres of prime farmland soils, and operation would permanently affect 23.4 acres of prime farmland soils. These soils are currently in silvicultural use or rice production and would be permanently removed from agricultural use.

Access roads would affect 7.9 acres of prime farmland soils during construction and 7.7 acres during operation. ATWS would affect 0.5 acre of prime farmland soils during construction; however, these areas would be restored following construction according to FERC's Plan. During construction, the pipe storage and contractor yard would temporarily affect 13.0 acres of prime farmland soils that were converted to industrial/commercial land use during construction of the existing Golden Pass Import Terminal.

Most impacts on prime farmland soils from construction of the pipeline would be short term and would not affect the potential use of prime farmland for future agricultural purposes. Golden Pass would implement the measures in FERC's Plan during construction and restoration, including minimizing the quantity and duration of soil exposure; segregating topsoil; installing temporary erosion controls such as silt fences, staked hay/straw bales, and sand bags; decompacting soil; and revegetating based on NRCS recommendations. Implementation of FERC's Plan would minimize potential impacts on prime farmland and restore the soils along the proposed route to pre-construction conditions. Construction and operation of the aboveground facilities (compressor stations and interconnects) would result in permanent impacts on 37.7 acres of prime farmland soil. Because of the amount of prime farmland in the vicinity of the Project and because the land could still be used for agricultural production after the pipeline is installed and the right-of-way reclaimed, the impact on prime farmland soils in the area would not be significant.

#### **4.2.3 Hydric Soils**

Hydric soils are formed under conditions of saturation, flooding, or ponding long enough during the growing season to develop anaerobic conditions in the upper soil horizon (NRCS, 2012b). These soils are typically associated with wetlands. Soils that are artificially drained or protected from flooding (e.g., by levees) are still considered hydric if the soil in its undisturbed state would meet the definition of a hydric soil.

##### **4.2.3.1 Terminal Expansion**

All of the soils present on the Terminal Expansion site are categorized as hydric soils because of their high water content. Except for the Sabine portion of the Sabine-Baines complex, all of the soils are listed as poorly to very poorly drained. Golden Pass would affect 831.8 acres of hydric soils, of which 760.4 acres would be permanently disturbed through operation of the proposed terminal facilities. We believe that this would be a significant environmental impact without mitigation; however, these impacts would be reduced to less-than-significant levels from implementation of the wetland mitigation and conservation measures identified in section 4.4.

##### **4.2.3.2 Pipeline Expansion**

All of the soils crossed by the Calcasieu Loop are categorized as hydric with high compaction potential because of their high water content and being poorly drained. The proposed 2.6-mile route would affect 16.3 acres of hydric soils during construction. If the pipeline is constructed when these soils are saturated, compaction and rutting could occur. Golden Pass would mitigate compaction impacts in residential and agricultural areas by decompacting soils during restoration, in accordance with FERC's Plan. High groundwater levels that accompany hydric soils could create a buoyancy hazard for the pipeline. In these areas, Golden Pass would use concrete-coated pipe.

All of the soils crossed by the aboveground facilities and access roads at MP 1, MP 63, MP 66, and MP 68 are characterized as hydric soils because of their high water content and being poorly to very poorly drained. In total, 56.9 acres of hydric soils would be affected by construction of the aboveground facilities (compressor stations, interconnects, and access roads). Disturbance of these soils also could cause compaction and rutting. After construction, 41.4 acres of hydric soils would be permanently disturbed from the footprint of the compressor stations, interconnects, and access roads. The remaining soils at the site would be restored in accordance with the mitigation measures contained in FERC's Plan.

The pipe storage and contractor yard consists of 13.0 acres of hydric soils.

Implementation of the measures contained in FERC's Plan would adequately minimize potential impacts on hydric soils during construction.

#### **4.2.4 Compaction Potential**

Soil compaction modifies the structure and reduces the porosity and moisture-holding capacity of the soil. The degree of soil compaction during construction depends on moisture content and soil texture. Fine-textured soils with poor internal drainage and high shrink-swell potential are the most susceptible to compaction. Construction equipment traveling over wet soils could disrupt soil structure, reduce pore space, increase runoff potential, and cause rutting. Moist or saturated soils are more likely to compact or rut.

##### **4.2.4.1 Terminal Expansion**

All of the soils at the Terminal Expansion site are susceptible to compaction and rutting. During construction, loss of soil productivity is likely to occur from compaction and damage to soil structure from heavy equipment. However, these areas would be developed; replaced by structures, paving, and gravel; and not used to support vegetation. Therefore, compaction is not a concern.

##### **4.2.4.2 Pipeline Expansion**

All of the soils that would be crossed by the Calcasieu Loop have a high compaction potential. Because of the presence of silt loam soils with poor drainage characteristics along the pipeline route, soil compaction has the potential to occur during construction.

Approximately 56.9 acres of soils that would be disturbed by construction of the aboveground facilities (compressor stations and interconnects and access roads) have a high compaction potential.

The pipe storage and contractor yard would affect 13.0 acres of soils with a high compaction potential, while ATWS would affect 3.6 acres of soils with a high compaction potential.

Compaction would be mitigated in agricultural areas crossed by the pipeline and at the aboveground facilities. FERC's Plan requires mitigation for soil compaction, including the use of timber mats or equivalent and low ground pressure equipment, segregating topsoil, and deep tillage operations during right-of-way restoration. We believe that implementation of these measures would adequately minimize soil compaction impacts resulting from construction of the Pipeline Expansion facilities.

#### **4.2.5 Erosion**

Erosion is a continuing natural process that can be accelerated by human activities. Factors that influence erosion potential include soil characteristics, climate, topography, vegetative cover, soil texture, surface roughness, percent slope, and length of slope. Water erosion typically occurs on loose, exposed soils with a low permeability on moderate to steep slopes. Wind erosion generally occurs in an arid climate with soils containing little vegetative growth and high wind conditions.

Clearing, grading, and equipment movement could accelerate the erosion process and, without adequate protection, result in discharge of sediment into waterbodies and wetlands. Soil loss due to erosion also could reduce soil fertility and impair revegetation rates.

#### **4.2.5.1 Terminal Expansion**

The erosion potential of soils at the Terminal Expansion site is minimal because of the cohesive nature of the soils and the flat topography of the site. None of the soils at the facility are listed as being highly erodible by water. Less than 5 percent of the soils are characterized as being highly erodible by wind. Golden Pass would further minimize the erosion potential of these soils by adhering to the erosion protection measures in FERC's Plan during construction and restoration of the expanded terminal. In addition, Golden Pass would install a revetment system in addition to shoreline protection measures for the Supply Dock to reduce potential erosion. Golden Pass would expand the existing shoreline protection system by constructing about 5,500 feet of new rock revetment (an armor stone layer about 4 feet thick and an 18-inch-thick stone bedding layer and geotextile fabric) to stabilize the actively eroding shoreline. In addition, about 4,100 feet of new revetment would be added on either side of the Supply Dock. Implementation of the measures outlined in FERC's Plan during construction, restoration, and operation would adequately minimize the potential for erosion.

#### **4.2.5.2 Pipeline Expansion**

All of the soils crossed by the Calcasieu Loop have a high potential for erosion by water, and 9.7 acres of soils have a high potential for wind erosion.

All of the soils that would be disturbed by construction of the MP 33, MP 66, and MP 68 facilities (compressor stations and interconnects) (39.6 acres) have a high potential for erosion by water. About 67 percent of the soils that would be affected by construction of the MP 33, MP 63, and MP 68 facilities have a high potential for wind erosion.

All of the soils in the proposed pipe storage and contractor yard (13.0 acres), 0.5 acre of soils affected by the ATWS, and 7.9 acres of soils crossed by access roads would have a high potential for erosion by water. None of the soils in the pipe storage and contractor yard, 0.5 acre of soils affected by the ATWS, and 6.0 acres of soils that would be crossed by access roads have a high potential for erosion by wind.

Construction would disturb soils, resulting in a temporary increase in the potential for erosion. To limit the effects of erosion, Golden Pass would implement the erosion control measures in FERC's Plan during construction of the pipeline, compressor stations, interconnects, and access roads. Golden Pass would implement and maintain these erosion and sedimentation control measures, such as silt fencing and hay bales, during construction and through restoration until successful revegetation has occurred. Following restoration, Golden Pass would monitor the disturbed areas, maintain erosion control structures, and repair observed erosion. Implementation of these measures during construction and restoration would minimize overall soil erosion.

#### **4.2.6 Revegetation Potential**

Successful restoration and revegetation in areas that are temporarily disturbed during construction is important to maintain ecosystem productivity and to protect the underlying soils from potential damage, such as erosion.

##### **4.2.6.1 Terminal Expansion**

None of the soils at the Terminal Expansion site have poor revegetation potential. However, Golden Pass has indicated that all areas, including the construction laydown areas, would be graveled or otherwise stabilized. Wetland mitigation measures to address these permanent impacts are discussed in section 4.4.

#### **4.2.6.2 Pipeline Expansion**

None of the soils that would be crossed by the pipeline, aboveground facilities, access roads, ATWS, or pipe storage and contractor yard have poor revegetation potential. Golden Pass would segregate up to 12 inches of topsoil in cultivated and rotated agricultural lands or in other areas requested by the landowner. The non-cultivated portions of the construction right-of-way would be revegetated in accordance with the measures contained in FERC's Plan and any specific landowner requests. This would include seeding disturbed areas with native vegetation as recommended by soil conservation authorities and monitoring all disturbed areas to ensure successful revegetation. If upland revegetation is conducted in accordance with these measures, areas disturbed by construction would be successfully revegetated to pre-construction conditions, and impacts on soils would be minor and temporary.

Once the pipeline is installed along the Calcasieu Loop, the right-of-way and the ATWS would be restored according to the restoration and reseeded measures contained in the FERC's. About 11.2 acres of the 22.0 acres disturbed during construction would be maintained as part of the permanent right-of-way. After the facilities are installed, Golden Pass would permanently maintain the compressor stations as fenced and graveled sites. A gravel cover also would be maintained at the interconnects and permanent access roads. Golden Pass would permanently affect all 31.4 acres disturbed during construction of the three compressor stations, 4.5 acres of the 13.1 acres disturbed during construction of the five interconnects, and 8.5 acres of the 8.6 acres of access roads used/upgraded during construction. Soils not permanently affected by operation of the aboveground facilities would be revegetated according to the measures contained in FERC's Plan. Implementation of FERC's Plan would minimize impacts on soils and adequately restore these areas.

#### **4.2.7 Soil Contamination**

Contamination from spills or leaks of fuels, lubricants, and coolant from construction equipment could adversely affect soils. Golden Pass developed an acceptable *Spill Prevention, Control, and Countermeasure Plan* (SPCC Plan) (see appendix F). It identifies clean-up procedures to be implemented in the event of soil contamination from spills or leaks of fuel, lubricants, coolants, or solvents. Implementation of the measures in the SPCC Plan would adequately minimize the potential for soil contamination.

##### **4.2.7.1 Terminal Expansion**

Golden Pass tested for the presence of contaminated soils from the dredged material placement at the existing terminal property and immediate vicinity. Assessment results indicated that the low levels of metals and organics present in the soils were below the applicable federal and state action levels. If unanticipated contaminated soil is discovered within the site, Golden Pass would follow the procedures of its SPCC Plan to minimize potential impacts.

##### **4.2.7.2 Pipeline Expansion**

The facilities would be within or adjacent to the previously disturbed soils along the existing Golden Pass Pipeline right-of-way. No potential hazardous waste sites were identified within 0.25 mile of the pipeline (NETR, 2013). If unanticipated contaminated soil is discovered within the site, Golden Pass would follow the procedures of its SPCC Plan to minimize potential impacts.



#### **4.2.8 Corrosion**

A geotechnical investigation for the existing terminal determined that soils in the tank area had a moderate risk of concrete degradation. Golden Pass would include additives such as fly ash and other pozzolonic materials (materials that will react with other materials to form compounds with cement-like properties) to the concrete mixture to counteract the effects of sulfates in the soil. Therefore, impacts associated with degradation would be minimized.

#### **4.2.9 Requested Modifications to the FERC Plan**

Golden Pass requested several deviations from the FERC Plan. Our evaluation and conclusions for the proposed deviations to the FERC Plan are presented in table 4.2-1.

TABLE 4.2-1

## Golden Pass' Requested Deviations from the FERC Plan

Reference	Description	Proposed Revision	Relevant Project Component(s)	Conclusion and Approval Status
Section III.F.1	Obtain written recommendations from the local soil conservation authorities or land management agencies regarding permanent erosion control and revegetation specifications.	Golden Pass proposes to permanently stabilize all areas, including construction laydown areas and the levee. These areas would not be revegetated.	Terminal Expansion	<b>Justified.</b> The Terminal Expansion site would be filled and used as construction laydown areas for the life of the Project. The filled laydown areas are required to create a safe, stable working surface. Permanently filling these areas also would reduce erosion.
Section IV.F.4.a	Apply mulch on all slopes (except in cultivated cropland) concurrent with or immediately after seeding, where necessary to stabilize the soil surface and to reduce wind and water erosion. Spread mulch uniformly over the area to cover at least 75 percent of the ground surface at a rate of 2 tons/acre of straw or its equivalent, unless the local soil conservation authority, landowner, or land managing agency approves otherwise in writing.	Golden Pass proposes to permanently stabilize all areas, including construction laydown areas and the levee. These areas would not be mulched or seeded.	Terminal Expansion	<b>Justified.</b> The Terminal Expansion site would be filled and used as construction laydown areas for the life of the Project. The filled laydown areas are required to create a safe, stable working surface. Permanently filling these areas also would reduce erosion.
Section V.D.2	Fertilize and add soil pH modifiers in accordance with written recommendations obtained from the local soil conservation authority, land management agencies, or landowner. Incorporate recommended soil pH modifier and fertilizer into the top 2 inches of soil as soon as practicable after application.	Golden Pass proposes to permanently stabilize all areas, including construction laydown areas and the levee. Golden Pass would not use soil additives in this area.	Terminal Expansion	<b>Justified.</b> The Terminal Expansion site would be filled and used as construction laydown areas for the life of the Project. The filled laydown areas are required to create a safe, stable working surface. Permanently filling these areas also would reduce erosion.

TABLE 4.2-1 (continued)

Golden Pass' Requested Deviations from the FERC Plan

Reference	Description	Proposed Revision	Relevant Project Component(s)	Conclusion and Approval Status
Section V.D.3.a-g	<p>Seeding Requirements</p> <ul style="list-style-type: none"> <li>a. Prepare a seedbed.</li> <li>b. Seed disturbed areas in accordance with written recommendations for seed mixes, rates, and dates obtained from the local soil conservation authority or the request of the landowner or land management agency</li> <li>c. Perform seeding of permanent vegetation within the recommended seeding dates.</li> <li>d. In the absence of written recommendations from the local soil conservation authorities, seed all disturbed soils within 6 working days of final grading, weather and soil conditions permitting.</li> <li>e. Base seeding rates on Pure Live Seed. Use seed within 12 months of seed testing.</li> <li>f. Treat legume seed with an inoculant</li> <li>g. In the absence of written recommendations from the local soil conservation authorities, landowner, or land managing agency to the contrary, a seed drill equipped with a cultipacker is preferred for seed application.</li> </ul> <p>Broadcast or hydroseeding can be used in lieu of drilling at double the recommended seeding rates.</p>	<p>Golden Pass proposes to permanently stabilize all areas, including construction laydown areas and the levee. These areas would not be seeded.</p>	<p>Terminal Expansion</p>	<p><b>Justified.</b> The Terminal Expansion site would be filled and used as construction laydown areas for the life of the Project. The filled laydown areas are required to create a safe, stable working surface. Permanently filling these areas also would reduce erosion.</p>

TABLE 4.2-1 (continued)

Golden Pass' Requested Deviations from the FERC Plan

Reference	Description	Proposed Revision	Relevant Project Component(s)	Conclusion and Approval Status
Section VII.A.5	Routine vegetation mowing or clearing over the full width of the permanent right-of-way in uplands shall not be done more frequently than every 3 years. However, to facilitate periodic corrosion/leak surveys, a corridor not exceeding 10 feet in width centered on the pipeline may be cleared at a frequency necessary to maintain the 10-foot corridor in an herbaceous state. In no case shall routine vegetation mowing or clearing occur during the migratory bird nesting season between April 15 and August 1 of any year unless specifically approved in writing by the responsible land management agency or the U.S. Fish and Wildlife Service.	Golden Pass proposes to mow the full width of the permanent right-of-way annually, outside of the area crossed via HDD.	Pipeline Expansion	<b>Not Justified.</b> Based on the FERC's experience, mowing the full right-of-way every 3 years is sufficient to allow periodic corrosion/leak surveys.
Section VII.B.1.a-f	<p><i>Reporting</i></p> <p>1. The project sponsor shall maintain records that identify by milepost:</p> <ul style="list-style-type: none"> <li>a. method of application, application rate, and type of fertilizer, pH modifying agent, seed, and mulch used;</li> <li>b. acreage treated;</li> <li>c. dates of backfilling and seeding;</li> <li>d. names of landowners requesting special seeding treatment and a description of the follow-up actions;</li> <li>e. the location of any subsurface drainage repairs or improvements made during restoration; and</li> <li>f. any problem areas and how they were addressed</li> </ul>	Golden Pass proposes an alternative measure from the required reporting of stabilization measures that does not include seeding, mulching, or soil additives.	Terminal Expansion	<b>Justified.</b> The Terminal Expansion site would be filled and used as construction laydown areas for the life of the Project. The filled laydown areas are required to create a safe, stable working surface. Permanently filling these areas also would reduce erosion.

## **4.3 WATER RESOURCES**

### **4.3.1 Groundwater**

#### **4.3.1.1 Existing Groundwater Resources**

The Project is in the Coastal Plain Physiographic Province above the Coastal Lowlands Aquifer System. The Coastal Lowlands Aquifer System underlies portions of southeast Texas, southern and central Louisiana, southern Mississippi, southern Alabama, and the western part of the Florida panhandle. It merges with the Mississippi River Valley alluvial aquifer at its northern boundary and extends to the edge of the continental shelf in the Gulf of Mexico at its southern boundary. The Coastal Lowlands Aquifer System is one of the most widely used aquifers in the southeastern United States. It is a major source of water for public consumption as well as for domestic, commercial, industrial, and agricultural uses (Renken, 1998).

Maximum total aquifer thickness of the Coastal Lowlands Aquifer System ranges from about 700 feet in the south to 1,300 feet in the north. Depth to the water table in Jefferson and Orange Counties in Texas ranges from 0 to 50 feet (Chowdhury and Turco, 2006). According to the Texas Water Development Board (TWDB), water contained within the Coastal Lowlands Aquifer System is generally fresh in the northern portion and brackish in the southern portion (TWDB, 2014a). Recharge to the Coastal Lowlands Aquifer System occurs when precipitation falls on the formation outcrops (SRAT 1999). The Coastal Lowlands Aquifer System is composed of the Chicot Aquifer, the Evangeline Aquifer, the Jasper Aquifer, and the Catahoula Aquifer. The Chicot and Evangeline aquifers are the two shallowest aquifers in the Coastal Lowlands Aquifer System. The bases of the Chicot and Evangeline aquifers are located from about 800 to 1,200 feet and 2,600 to 4,000 feet below ground surface, respectively, at the existing Golden Pass Import Terminal (FERC, 2005).

The TWDB categorizes aquifer systems as major or minor aquifers in Texas. Major aquifers supply large amounts of water over large areas, and minor aquifers supply minor amounts of water over large areas or large amounts of water over small areas (TWDB, 2014a). The Coastal Lowlands Aquifer System is designated as a major aquifer; however, areas of generally brackish water that extend about 10 miles inland from the shore are not included in this designation. The portion of the Project in Orange County overlies a major aquifer, but the portion of the aquifer that underlies Jefferson County is not designated as a major aquifer (TWDB, 2014b). The Project is not over any TWDB-designated minor aquifers (TWDB, 2014c).

Along the Louisiana portion of the Project, the Chicot Aquifer consists of several layers of productive units of sand below dense surficial clay deposits, which act as confining units (USGS, 2004). The sand layers are named according to their depths and include the 200-foot, 500-foot, and 700-foot sands (USGS, 1998). Thickness of the Chicot Aquifer in Calcasieu Parish is variable depending on location; it ranges from about 50 to 325 feet. Similarly, depth to the Chicot Aquifer in Calcasieu Parish varies with location and ranges from about 6 to 196 feet below the ground's surface. The confining layer in the Pipeline Expansion area is about 80 to 120 feet thick (USGS, 2004). Recharge to the aquifer system occurs by precipitation infiltration, water movement through nearby alluvium deposits, upward water movement from the underlying Evangeline Aquifer, and inflow from the Vermillion and Calcasieu Rivers (LDEQ, 1996). Heavy pumping of the Chicot Aquifer in Texas has led to saltwater encroachment in coastal portions of Jefferson County and has caused saltwater intrusion to occur in areas as far north as Orange County (Ashworth and Hopkins, 1995; TWDB, 2006, 2014d). Years of excessive pumping have led to declines in the water table levels in both Jefferson and Orange Counties in Texas (Ashworth and Hopkins, 1995). Orange County municipal demand is the greatest for use of groundwater pumped from the Coastal Lowland Aquifer System for public supply (SRAT, 1999). Orange County residents use water obtained from the

lower unit of the Chicot Aquifer as their primary source of freshwater for public consumption and industrial use (USGS, 1987).

The groundwater beneath the existing Golden Pass Import Terminal is considered saline and therefore is classified by the TCEQ as Class 3 groundwater. Class 3 groundwater resources are not considered usable as drinking water and are not subject to groundwater ingestion protective concentration levels (PCL). However, they are subject to less restrictive PCLs specifically assigned to Class 3 groundwater (TCEQ, 2010).

The Chicot Aquifer is the principal source of groundwater in both Calcasieu Parish and the entire state of Louisiana. It provided nearly half of all groundwater withdrawals in Louisiana in 2010 (USGS, 1998, 2010). In 2011, about 649 million gallons of water per day (Mgal/d) of groundwater were withdrawn from the Chicot Aquifer state-wide, with Calcasieu Parish accounting for about 86 Mgal/d of that total. The most common use of water drawn from the aquifer in 2011 was rice irrigation (about 342 Mgal/day), followed by aquaculture (about 114 Mgal/day) and public water supply (about 97 Mgal/day) (LGWRC, 2012). Water levels in the Chicot Aquifer have declined in some areas of Louisiana because of extensive pumping of this aquifer, which has led to concern that saltwater intrusion could occur (USGS, 2010). The LDEQ sampled six Calcasieu Parish groundwater wells supplied by the Chicot Aquifer between 2000 and 2003, and found that the water did not exceed any primary maximum contaminant levels (LDEQ, 2003a, 2003b).

## **Protected Groundwater and Springs**

### Sole Source Aquifers

The EPA defines a sole or principal source aquifer as one that supplies at least 50 percent of the drinking water consumed in the area overlying the aquifer and for which no alternative drinking water sources exist that could physically, legally, and economically supply all those who depend on the aquifer for drinking water (EPA, 2012a). The Terminal Expansion, MP 1 Compressor Station, NGPL Interconnect, MP 33 Compressor Station, and Texoma Interconnect in Texas would not overlie a sole source aquifer (EPA, 2012b). The Chicot Aquifer in Louisiana has been designated by EPA as a sole source aquifer (EPA, 2008). Thus, the Pipeline Expansion, MP 66 Compressor Station, TGP Interconnect, TETCO Interconnect, and Transco Interconnect in Louisiana would overlie a sole source aquifer.

### Protected Watersheds

Groundwater Conservation Districts are the State of Texas's preferred method of groundwater management. Groundwater Conservation Districts are locally governed districts established "...to manage groundwater by providing for the conservation, preservation, protection, recharging, and prevention of waste of the groundwater resources within their jurisdictions" (TCEQ, 2014a). The TCEQ, the TWDB, and the TPWD are authorized to identify and delineate Priority Groundwater Management Areas in Texas. The Priority Groundwater Management Area Program is used to "...identify areas of Texas experiencing, or expected to experience, critical groundwater problems and encourage the creation of GCDs [Groundwater Conservation Districts] for those areas" (TCEQ, 2014b). Neither Jefferson nor Orange County is within a Groundwater Conservation District or a Priority Groundwater Management Area; therefore, no protected watersheds are in or within 150 feet of the proposed facilities in Texas (TCEQ, 2013a, 2014c; TWDB, 2014e).

In Louisiana, the LDEQ established the Louisiana Wellhead Protection Program "...to protect the quality of public drinking water supplies obtained from community water wells...." In accordance with the Louisiana Wellhead Protection Program, wellhead protection areas are delineated around community wells. A wellhead protection area usually has a radius of 1,000 feet to 1 mile, depending on the depth of the well

it surrounds (LDEQ, 2014a). The Louisiana portion of the Project does not cross any wellhead protection areas (LDEQ, 2014b).

### Springs

No springs have been identified on, or within 150 feet of, the Terminal Expansion or Pipeline Expansion.

### **Public and Private Water Supply Wells**

Groundwater in the vicinity of the existing Golden Pass Import Terminal has been designated as Class 3 groundwater due to its high salinity levels and is not classified for use as drinking water (TCEQ, 2010). Therefore, no registered public supply water wells are within 0.5 mile of the Project facilities in Jefferson County, Texas. Drinking water is supplied to the area from the City of Port Arthur municipal water supply, which comes from surface water sources (CPA, 2012).

In Orange County, Texas, groundwater from the Chicot Aquifer is widely used for public consumption (USGS, 1987). According to the TWDB Well Location Grid, no water wells are within 150 feet of the Project facilities in Orange County, Texas (TWDB, 2013).

The majority of the public water supply in Calcasieu Parish, Louisiana, comes from groundwater in the 500-foot sand layer of the Chicot Aquifer via public supply wells; a lesser portion of groundwater from this layer is accessed by private and domestic wells (USGS, 1998, 1999). Domestic groundwater supplies in Calcasieu Parish also are derived from the 200-foot sands of the Chicot Aquifer, or the “shallow sands.” Domestic wells are located in the shallow sands throughout Calcasieu Parish (USGS, 2004).

A review of the Louisiana Department of Natural Resources (LDNR) Strategic Online Natural Resources Information System indicates that no municipal or residential wells are within 150 feet of the Pipeline Expansion in Calcasieu Parish. One active irrigation well was identified within 150 feet of the construction right-of-way for the pipeline (LDNR, 2013). The location of this well has not been field-verified.

#### **4.3.1.2 Groundwater Impacts and Mitigation**

Impacts on groundwater resources could result from construction and operation of the Project. These potential impacts are discussed below.

### **Terminal Expansion**

Golden Pass would drive pilings to support the liquefaction facilities. About 25,000 piles would be required for construction of the Terminal Expansion and the MP 1 Compressor Station, and about 800 piles are expected for construction of the Supply Dock. Pile types used for the onshore facilities would be steel pipe piles, precast concrete piles, and potentially displacement piles. Those used for offshore construction would be made of concrete. About 10 of the piles that would be needed for the Supply Dock would be installed offshore by a construction barge. The depths to which the piles would be driven would range from 100 to 150 feet, depending on load weight and pile capacity. Golden Pass does not anticipate the need for dewatering during pile construction activities. Pilings could create conduits for contaminants to potentially affect surficial groundwater but likely would not intrude into the shallowest aquifer (a 200-foot-deep sand aquifer). Pilings would be confined to the surficial layers of the aquifer system. The dense surficial clays that confine the 200-foot-deep sand layer of the aquifer would prevent movement into and contamination of the aquifer. In addition, groundwater beneath the Terminal Expansion area is considered Class 3 groundwater, which is not suitable for human consumption (TCEQ, 2010). Groundwater resources

in the area of offshore pile driving are seaward of the Gulf Coast Aquifer in areas where aquifers would contain brackish or saline waters. Therefore, installation of pilings during construction would have little or no effect on groundwater.

The Project would require dredging for construction of the Supply Dock and associated water navigation channels (e.g., access channel and temporary float channels). Golden Pass would dredge about 455,450 yd<sup>3</sup> of material for the Supply Dock, access channel, and the associated temporary float channels. The Supply Dock would be along an unimproved portion of SNWW shoreline that forms the eastern side of the existing terminal property boundaries. The access channels would be constructed in submerged sediments from the Port Arthur Ship Canal to a portion of the SNWW adjacent to the Supply Dock. Both the Supply Dock and access channel would be dredged to 20 feet below MSL (plus or minus 2 feet of depth). The temporary float channels would be dredged to 7 feet below MSL (plus or minus 2 feet of depth). The shoreline protection system could be constructed using an onshore, land-based construction approach; a boat-based water approach; or a combination of the two. Potential impacts on groundwater associated with dredging activities would be limited to those that would occur as part of construction of the Supply Dock, which is anticipated to take from 2 to 3 months to complete. However, because groundwater in this area is seaward of the Gulf Coast Aquifer in areas where groundwater would contain high salinity levels, dredging would not affect fresh groundwater resources.

Impacts on groundwater resources could occur due to an accidental spill, leak, or other release of a hazardous substance during construction or operation of the expanded terminal. Should a release occur, Golden Pass would adhere to measures outlined in its SPCC Plan to minimize potential impacts on groundwater resources (see appendix F).

As noted in section 4.3.1.1, the soils between the Chicot Aquifer and surficial aquifers have a low permeability because of the presence of a thick surficial confining unit made of dense clays with interbedded sands (USGS, 2004). Therefore, if a hazardous substance is released, it may not reach the 200-foot sand portion of the aquifer. In addition, with implementation of the measures contained in the SPCC Plan during construction and operation, it is not likely that an accidental release of hazardous substances would result in a significant impact on groundwater resources. If contaminated groundwater is encountered during construction, Golden Pass would suspend construction activities, evacuate the area (if necessary), notify the appropriate agencies, and analyze and clean up the area.

The Terminal Expansion would result in conversion of 471.9 acres to industrial land—including gravel and impervious surface—in the Project area, thereby reducing groundwater infiltration in the area of the terminal site. Because of the abundance of wetlands and surface water in the surrounding area that continuously recharge groundwater resources, the reduction of groundwater infiltration at the Terminal Expansion site is not anticipated to affect groundwater levels. Further, because groundwater in this area is classified as brackish to saline and is not suitable as a source of potable water, the quality of the groundwater would not be adversely affected as a result of the permanent conversion of this area to an industrial land use.

Hydrostatic testing of the new piping and LNG tanks at the Terminal Expansion would be conducted to ensure the integrity of these components before placing the facility into service. Piping also would be flushed with water to remove any solids that may be present. Hydrostatic testing and pipe flushing at the Terminal Expansion would require about 7,500,000 gallons of water. The source for hydrostatic test and pipe-flushing water for the Terminal Expansion would be municipal water or purchased raw water. No additives, such as biocides or oxygen scavengers, would be used for hydrostatic testing or pipe flushing activities. Hydrostatic test water would be discharged into the SNWW in accordance with the BMPs outlined in FERC's Plan and Procedures. Groundwater would not be used for hydrostatic testing; therefore, no impacts on groundwater are expected to occur as a result of hydrostatic testing at the Terminal Expansion.



Water needed for other construction-related activities, such as drinking water, sanitation water, dust suppression, and general cleaning activities, would be obtained from the Port Arthur Drinking Water Utility (DWU). Domestic sewage and used sanitation water at the Terminal Expansion and the MP 1 Compressor Station would be managed through installation and use of a dedicated waste collection and treatment system. The water would be treated using an extended aeration biological package system, after which it would be discharged into the SNWW. Dust generated from vehicular and equipment traffic could increase sedimentation of the SNWW. To mitigate this effect, Golden Pass proposes to use municipal water obtained from a water line adjacent to the existing terminal along SH-87 for dust control during construction activities in Jefferson County, Texas. Golden Pass estimates that about 8,000 gallons per day of municipal water would be required for dust control. Given that weather conditions would play a large role, it is impossible to predict precisely how much water would be needed for dust suppression. General cleaning activities requiring water during construction would include onsite office cleaning (e.g., office bathrooms, and kitchens), site vehicle cleaning and maintenance, building exterior and sidewalk washing, and rinsing non-hazardous materials from construction equipment. Table 4.3-1 provides the approximate amounts of water and its source(s) that would be required for construction of the Project.

Groundwater withdrawals would not be required during operation of the Terminal Expansion. Air would be used to cool natural gas at the liquefaction facilities, and the Port Arthur DWU would supply water to meet facility requirements. Therefore, groundwater quantities would not be affected. The average daily water usage rate during operation of the Terminal Expansion is anticipated to be about 550 gpm.

Using the measures discussed above, we believe that impacts on groundwater resources during construction and operation of the Terminal Expansion would be minimized.

### **Pipeline Expansion**

The Chicot Aquifer is an EPA-designated sole source aquifer that underlies the entire Pipeline Expansion route in Louisiana. A layer of clay about 50 to 100 feet thick overlies the Chicot Aquifer within the area of the Pipeline Expansion; this layer separates the Chicot Aquifer from the surficial groundwater resources. In general, the depth of the trench excavation would be relatively shallow (6 feet) compared to the depth of the Chicot Aquifer in the Project area. The pipeline would be installed deeper than 6 feet in areas where the right-of-way would cross other pipelines, roads, and agricultural ditches, and for the HDD installations. Given the depth of the Chicot Aquifer boundary and the presence of a thick clay layer over it, construction of the Pipeline Expansion—including those areas that require depths greater than 6 feet—would not adversely affect the Chicot Aquifer or its groundwater quality.

In areas where surficial groundwater is near the ground surface, trench excavation could intersect the water table, requiring trench dewatering. Trench dewatering may result in localized, minor changes to the water table, which also could affect the hydrology of nearby wetland areas. Because Golden Pass would complete Pipeline Expansion construction at a given location within a short period, when water would be discharged to nearby vegetated areas, potential dewatering impacts would be temporary and localized. Water table elevations would reestablish soon after the trench is backfilled. Where the trench may be continually flooded and dewatering would not be feasible, Golden Pass would use push-pull or float techniques to place the pipe in the trench (see section 4.4.3.1 for a description of these methods).

During construction, trench excavation, grading, and filling of the excavated trench could cause minor fluctuations in shallow groundwater levels or increase turbidity within shallow groundwater adjacent to the construction activity. These impacts would be limited to the area of disturbance and would not cause a significant impact on groundwater quality or quantity.

<b>TABLE 4.3-1</b>			
<b>Water Requirements for Construction of the Golden Pass LNG Export Project</b>			
<b>Description of Use</b>		<b>Approximate Volumes (total gallons)</b>	<b>Water Source</b>
Hydrostatic testing	Terminal Expansion	7,500,000 <b>a</b>	Municipal or raw water
	Pipeline	300,000	Municipal or raw water
	HDD string	125,000	Municipal or raw water
	MP 1 Compressor Station and NGPL Interconnection	75,000	Municipal or raw water
	MP 33 Compressor Station and Texoma Interconnection	35,000	Municipal or raw water
	Tennessee Gas Interconnection	<10,000	Municipal or raw water
	MP 66 Compressor Stations and TETCO Interconnection	240,000	Municipal or raw water
	Transco Interconnection	<10,000	Municipal or raw water
	<b>Subtotal</b>	<b>8,295,000 <b>b</b></b>	
Human consumption	Drinking water <b>c</b>	8,305,000	Port Arthur DWU
	Ice production	2,500,000	Port Arthur DWU
	Sanitation water <b>d</b>	16,610,000	Port Arthur DWU
	<b>Subtotal</b>	<b>27,415,000</b>	
Other <b>e</b>	Concrete production <b>e</b>	NA	NA
	Truck cleaning <b>e</b>	NA	NA
	General cleaning	6,650,000	Port Arthur DWU
	<b>Subtotal</b>	<b>6,650,000</b>	
<b>TOTAL</b>		<b>42,360,000</b>	
<b>Notes:</b>			
<b>a</b>	Includes pipe hydrostatic test water, pipe flush water, and hydrostatic test water for the tanks.		
<b>b</b>	Sum is conservative; "<10,000" is considered to be "10,000" when calculating the total.		
<b>c</b>	Assumes 2.5 gallons of water per day per workforce member.		
<b>d</b>	Refers to portable toilets. However, the use estimate was made based on the water-usage requirements of flushable toilets and assumes four toilet flushes per day per workforce member.		
<b>e</b>	Concrete production and truck cleaning services would be provided from an outside contractor.		

Near-surface soil compaction caused by heavy construction vehicles could locally reduce the soil's ability to absorb water, which would increase surface runoff and the potential for ponding. In areas of vegetation clearing, water infiltration normally enhanced by the vegetation would reduce locally until the area is revegetated, which could temporarily affect water recharge to deeper aquifer layers. However, Golden Pass would adhere to measures in the FERC's Plan and Procedures to minimize impacts on groundwater during construction of the Pipeline Expansion, including installing trench breakers to prevent groundwater movement or loss from nearby wetlands; restoring contours to pre-construction conditions; and revegetating the right-of-way, where practicable, to ensure restoration of pre-construction overland flow and recharge patterns. With implementation of these measures, impacts on groundwater would be minor and temporary.

Spills of construction fuels, lubricants, and other potentially hazardous substances could affect shallow groundwater and unconsolidated aquifers. Potential contamination due to accidental spills or leaks

of hazardous materials associated with vehicle fueling, vehicle maintenance, and storage of construction materials presents the greatest potential threat to groundwater resources during construction of the Pipeline Expansion and aboveground facilities. Golden Pass would adhere to the BMPs outlined in FERC's Plan and Procedures in addition to the guidelines stated in the Golden Pass SPCC Plan to minimize the potential for a spill. The SPCC Plan also provides acceptable measures to avoid or minimize impacts on groundwater and other resources, should a release occur (see appendix F).

The 50- to 100-foot thick layer of clay that overlies the Chicot Aquifer within the area of the Pipeline Expansion—along with implementation of measures in FERC's Plan and Procedures during construction and the SPCC Plan during operation of the three new compressor stations—would avoid or minimize potential impacts on groundwater from spills of hazardous substances.

Golden Pass would hydrostatically test the pipeline before initiating operation. About 795,000 gallons of water<sup>19</sup> would be required for hydrostatic testing of the Calcasieu Loop, compressor stations, interconnections, and the HDD string. The source water that would be used for hydrostatic testing of these Project components would be municipal water or purchased raw water. Additives, such as biocides or oxygen scavengers, would not be used during hydrostatic testing. Test water would be discharged within the construction right-of-way through an energy-dissipating device to minimize erosion. Impacts on groundwater as a result of discharging test water into upland areas may result in minor fluctuations in shallow groundwater levels or increase turbidity in shallow groundwater adjacent to the construction activity. These impacts would be limited to the area of disturbance and are not expected to significantly affect groundwater quality or quantity. All hydrostatic testing discharges for Project facilities in Louisiana would be covered under the existing terminal's Louisiana Pollutant Discharges Elimination System General Permit for Discharges of Hydrostatic Test and Vessel Testing Wastewater (LAG679126).

Golden Pass does not anticipate the need for dewatering during pile construction activities. As discussed in section 4.3.1.2, pilings could create conduits for contaminants to potentially affect surficial groundwater. However, relatively shallow piling installations that are not likely to intrude into the shallowest aquifer (the 200-foot-deep sand aquifer), in conjunction with the presence of a thick layer of surficial clays, likely would preclude impacts on groundwater.

During operation of the three new compressor stations, potable water would be supplied by a new water well with a design capacity of 10 gpm. The daily water demand for each compressor station is projected to be about 140 gallons per day. Golden Pass would install an underground septic system at the MP 33 and MP 66 Compressor Stations, in accordance with local and state permits, to manage sanitary and sewage wastewater. Installation of the septic system could cause minor fluctuations or increase turbidity in shallow groundwater within the construction area, similar to trenching and pipeline installation. Seepage or other leaks from the septic system could contaminate groundwater; however, proper maintenance reduces the likelihood of seepage or other leaks. In addition, the low permeability of sediments between the Chicot Aquifer and surficial aquifers would avoid or minimize impacts on groundwater due to seepage or leaks from the septic tank. Should they occur, these impacts would be limited to the area immediately adjacent to the proposed tank and we believe would not significantly affect groundwater quality or quantity in the area.

Golden Pass would monitor the irrigation well within 150 feet of the Project area in Calcasieu Parish prior to, during, and following construction to ensure that Project construction activities are not diminishing water quality or yield. If it is determined that the Project negatively affected the well, Golden Pass would restore the well to its pre-construction condition and would provide its users an alternate source

---

<sup>19</sup> The total hydrostatic test volumes of water were calculated using conservative measures by assuming that the approximate volumes needed to test the Tennessee Gas Interconnect and the Transco Interconnect are 10,000 gallons each, despite estimates that the approximate volumes would be less than 10,000 gallons each.

of water until the well has been restored. Should additional water wells be identified during construction, Golden Pass would monitor the wells during and after construction to ensure that water quality and yield are not affected.

### Pipe Storage and Contractor Yard

The pipe storage and contractor yard would occupy 13.0 acres in Orange County, Texas. The site has been cleared of vegetation and covered with gravel. No wetlands or waterbodies are located at the site. According to the TWDB's Well Location Grid website, no groundwater wells or springs are within 150 feet of the site (TWDB, 2013). Access to the site would be obtained using existing roads. Golden Pass would grade and re-gravel the access roads, as necessary; the need for additional modifications is not anticipated. Following construction, Golden Pass would restore the site to pre-construction conditions, in adherence to FERC's Plan. Therefore, impacts on groundwater resources are not likely to occur as a result of Project-related activities at the pipe storage and contractor yard site.

## **4.3.2 Surface Water**

### **4.3.2.1 Existing Surface Water Resources**

The Project is within four watersheds: Sabine Lake, Lower Neches, West Fork Calcasieu, and the Lower Calcasieu. Table 4.3-2 provides the approximate distance of each watershed that would be crossed by Project component. The Sabine Lake watershed encompasses an area of about 1,040 square miles in Texas and Louisiana and flows to the Gulf of Mexico. The Lower Neches watershed covers about 1,130 square miles in Texas. The West Fork Calcasieu watershed includes about 818 square miles in Louisiana, and the Lower Calcasieu watershed extends over about 1,270 square miles in Louisiana (EPA, 2013a).

Project construction would affect four waterbodies: the SNWW, two unnamed roadside ditches, and one unnamed agricultural ditch. The FERC classifies surface waters based on size: major waterbodies are greater than 100 feet wide, intermediate waterbodies are greater than 10 feet wide but less than or equal to 100 feet wide, and minor waterbodies are less than or equal to 10 feet wide. One major waterbody, the SNWW, would be affected by the Project. The remaining waterbodies crossed by the Project are classified as intermediate or minor. The SNWW is state-classified for uses outside of agriculture, including primary contact recreational use, aquatic life, and fish consumption (LAC, 2015; TCEQ, 2012a). Project impacts on waterbodies would be related to dredging, filling, and construction crossing activities. Section 4.3.2.2 provides more information of the potential Project-related impacts on surface waterbodies. Table 4.3-3 provides a list of the waterbodies along the Project, their locations, the Project milepost (if applicable), their state waterbody classifications, the type and approximate extent of impacts, and the impairment status according to Section 303(d) of the CWA.

**TABLE 4.3-2**

**Watersheds Crossed by the Golden Pass LNG Export Project**

<b>Watershed</b>	<b>Location of Watershed within Project Area (County/Parish and State)</b>	<b>Project Component(s) within the Watershed</b>	<b>Project Crossing Distance (miles) <sup>a</sup></b>
Sabine Lake	Jefferson County, Texas	Terminal Expansion, MP 1 Compressor Station, NGPL Interconnection	2.6
Lower Neches	Orange County, Texas	MP 33 Compressor Station, Texoma Interconnection, Pipe Storage and Contractor Yard	0.7
West Fork Calcasieu	Calcasieu Parish, Louisiana	Tennessee Gas Interconnection, Calcasieu Loop, MP 66 Compressor Station, TETCO Interconnection	3.5
Lower Calcasieu	Calcasieu Parish, Louisiana	Transco Interconnection	0.2

**Note:**

**a** Maximum linear crossing distance of permanent facilities.

TABLE 4.3-3

Waterbodies Crossed by the Golden Pass LNG Export Project

Waterbody Name	Location in Project Area (County/Parish)	Project Component Crossing the Waterbody	Project Crossing Location MP <u>a</u>	Waterbody Type	FERC Class	State Water Classification	Type of Impact	Crossing Distance (feet)	Dredging Requirements <u>b</u> (cubic yards)	Fill Requirements (acres)	303(d) Impairment Status in the Project Area <u>c</u>
SNWW	Jefferson County, TX	Terminal Expansion (Supply Dock, temporary float channels, and access channel)	NA	Estuarine, tidal	Major	High Aquatic Life Use, Primary Contact Recreation Use, General Use, Fish Consumption	Dredge	NA	455,450	NA	Listed for bacteria and PCBs in edible tissue <u>d, e</u>
NA	Calcasieu Parish, LA	Calcasieu Loop	~1.5	PUB (agricultural ditch)	Intermediate	Agricultural	Open-cut crossing	20	NA	NA	Not listed
NA	Calcasieu Parish, LA	MP 66 Compressor Station	Access road near ~MP 2.0	PUB (roadside ditch)	Minor	Agricultural	Open-cut crossing	<10	NA	<0.1	Not listed
NA	Calcasieu Parish, LA	MP 66 Compressor Station	Access road near ~MP 2.0	PUB (roadside ditch)	Minor	Agricultural	Open-cut crossing	<10	NA	<0.1	Not listed

Sources: USDC, 2002; LAC, 2015; TCEQ, 2014d

Abbreviation:  
 NA = not applicable  
 PUB = palustrine unconsolidated bottom

Notes:  
a The Project milepost at which the Project would first cross the waterbody.  
b Does not include pipeline trench excavation.  
c As listed on the applicable state's 303(d) list as required under the CWA.  
d The TCEQ's 2014 303(d) list has not been finalized.  
e Two segments of the SNWW are monitored by the TCEQ. The segment that is listed for PCBs in edible tissue is not adjacent to the Project area.

## Terminal Expansion

The Terminal Expansion would be entirely within the Sabine Lake watershed. The SNWW is the sole waterbody that would be affected by the Terminal Expansion. The SNWW is an estuarine, perennial waterbody that forms the existing terminal's eastern and northern property boundaries. The Terminal Expansion is 5.6 miles north of the Gulf of Mexico on the SNWW's western shore, in the vicinity of the existing terminal facilities. It is classified as an estuary in Jefferson County, Texas. The SNWW is a 79-mile ship channel that extends from the Gulf of Mexico north to Orange, Texas, and beyond via the Sabine River Channel. The SNWW is the fourth most widely used shipping channel in the United States in terms of total tonnage (COE, 2012a). The SNWW has been subject to significant alterations that began prior to construction of the existing terminal, such as its initial channel dredging, widening and deepening projects, fill placement projects, changes to water flow direction, installation and abandonment of a railroad grade, and third-party pipeline installations. The channel is a Traditional Navigable Water as defined by 33 CFR 329 and is maintained by the COE. It currently is about 40 feet deep, but dredging to a depth of 48 feet recently was authorized (SNND, 2014).

As described in section 2.2.1.5, the Project requires installation of a supply dock and temporary float channels and an access channel in the SNWW. This would require initial dredging of about 455,450 yd<sup>3</sup> of sediment from the waterbody. Additional dredging would be required to maintain the Supply Dock and access channel. A discussion of the potential dredging impacts on the SNWW's water quality is provided in section 4.3.2.2.

Because of the current and historical industrial use of the SNWW, the potential exists for chemical contamination. Two TCEQ-classified segments of the SNWW are monitored for water quality in the vicinity of the Terminal Expansion. One of these segments, which lies downstream of the existing terminal, was listed in 2012 as impaired under Section 303(d) of the CWA for the presence of polychlorinated biphenyls (PCBs) in edible tissue and currently is listed on the TCEQ's draft 2014 303(d) list for bacteria and PCBs in edible tissue. The other segment, which is adjacent to the Terminal Expansion, was not listed as impaired in 2012 but is listed for bacteria in the draft 2014 report (TCEQ, 2014d). The SNWW is used for commercial and recreational fishing; however, the waterbody is not considered prime fish habitat. Potential Project-related impacts on recreational and commercial and fishing are discussed in more detail in sections 4.8.4 and 4.9.6, respectively.

### Contaminated Sediments

Contaminants can accumulate in the sediments of contaminated waterbodies. Therefore, sediments in the Project area that are located in waters with the potential for contamination also have the potential to be contaminated. A portion of the SNWW located within the Project area is listed on the Texas draft 2014 303(d) List of Impaired Waters (TCEQ, 2014d). None of the other waterbodies in the Project area are listed on their respective state's 303(d) List of Impaired Waters. Golden Pass did not identify any areas of sediment contamination during permitting and construction of the existing terminal (EPA, 2004; FERC, 2005; URS, 2005). In March 2015, Golden Pass conducted sediment and water sampling for chemical analysis at the existing Ship Slip. The chemical analysis report provides laboratory results that were compared against applicable, COE-selected screening benchmarks.<sup>20</sup> Screening benchmarks used for water analytical results were developed by the TCEQ, the NOAA, and the EPA. For sediment analytical results, the COE chose screening benchmarks developed by the NOAA and the EPA. The results of this study show that all measured analytes were absent or present at levels significantly below their respective

---

<sup>20</sup> Results of the sediment and water testing of the existing Ship Slip can be accessed at: [http://elibrary.ferc.gov/0/idmws/file\\_list.asp?document\\_id=14345059](http://elibrary.ferc.gov/0/idmws/file_list.asp?document_id=14345059).

benchmark's effects range median values. These values represent contaminant concentrations above which toxic effects frequently occur (BES, 2015).

The chemical analysis report has undergone some informal agency review, including a review by the EPA. However, the EPA has not provided comments on the results. Although the COE has not yet reviewed the report, they indicated that dredge material with high levels of certain contaminants may still be suitable for beneficial use projects<sup>21</sup>. Because the EPA and the COE have not provided their comments on the results, **we recommend that:**

- **Prior to the end of the draft EIS comment period, Golden Pass should work with the EPA and the COE to obtain the agencies' full review of the water and sediment chemistry analysis conducted at the existing Ship Slip. Golden Pass should file the conclusions of the reviews with the Secretary along with documentation of its consultations with these agencies.**

#### Sensitive Waterbodies

Waterbodies may be considered sensitive for a number of reasons, including the presence of significant fisheries, habitat for threatened or endangered species, high-quality recreational or visual resources, historic value, or impaired water or contaminated sediments. The closest TPWD-listed ecologically significant waterbody is about 0.25 mile from the Terminal Expansion (LDWF, 2013a; TPWD, 2013a). As previously stated, no areas of potential sediment contamination were identified in the Project area (EPA, 2004; FERC, 2005; URS, 2005).

#### Potable Water Intakes

No potable water intakes are within 3 miles downstream of the Terminal Expansion site.

#### **Pipeline Expansion**

The Pipeline Expansion facilities are within four separate watersheds: the Sabine Lake watershed, the Lower Neches watershed, the West Fork Calcasieu watershed, and the Lower Calcasieu watershed. Table 4.3-2 lists the watershed(s) that would be crossed by each Project component, the location at which the respective component first enters the watershed, and the distance of the crossing.

Construction of the pipeline and modifications to an existing access road associated with the MP 66 Compressor Station would affect one agricultural ditch and two roadside ditches (see table 4.3-3). No impacts on waterbodies would be associated with the MP 33 Compressor Station or any of the interconnection sites. The agricultural ditch is classified as an intermediate waterbody, and the two roadside ditches are classified as minor waterbodies. The ditch is about 20 feet wide at the proposed crossing location and would be crossed using the open-cut wet trench crossing method. The agricultural ditch is classified as a man-made waterbody with a palustrine unconsolidated bottom (PUB).

The two roadside ditches are also man-made PUB waterbodies. They are located along an existing access road leading to the site of the MP 66 Compressor Station in Calcasieu Parish. Golden Pass is proposing to fill a portion of the ditches as part of improvements to the access road. Since these roadside ditches provide drainage pathways for roadway runoff and reduce the risk of localized flooding, Golden Pass should use an appropriate waterbody crossing method while modifying its access road to cross the two

---

<sup>21</sup> Telephone conversation between the FERC staff and the COE, Galveston District on August 11, 2015.



roadside ditches at the MP 66 Compressor Station using measures provided in FERC's Procedures. Therefore, **we recommend that:**

- **Prior to the end of the draft EIS comment period, Golden Pass should file with the Secretary appropriate access road crossing methods for the two roadside ditches at the MP 66 Compressor Station. Golden Pass should restore the ditches to their original contours following installation of the compressor station.**

No additional waterbodies would be affected by construction or operation of the Pipeline Expansion.

#### Contaminated Sediments

As noted above, the waterbodies crossed by the Pipeline Expansion are not listed on Louisiana's 303(d) List of Impaired Waters. Therefore, contaminated sediments are not expected to be encountered in waterbodies along the Pipeline Expansion route.

#### Sensitive Waterbodies

No Scenic River systems are crossed by the Project. As previously stated, no areas of potential sediment contamination were identified in the Project area (EPA, 2004; FERC, 2005; URS, 2005).

#### Potable Water Intakes

The Pipeline Expansion would not cross any waterbodies within 3 miles upstream of any public water intake.

#### Pipe Storage and Contractor Yard

There are no waterbodies at the proposed pipe storage and contractor yard site in Orange County, Texas.

### **4.3.2.2 Surface Water Impacts and Mitigation**

Direct impacts on surface water resources are defined as those Project-related impacts that occur to waterbodies in the construction workspace that are temporarily or permanently disturbed and for which the acreage of impacts can be calculated. Direct impacts could include turbidity and sedimentation associated with construction activities and alterations to the depth of the waterbody (e.g., filling or dredging). Indirect impacts on surface water resources occur outside of the construction workspace and could include potential changes in flow regime or water quality.

#### **Terminal Expansion**

As previously stated, the SNWW is the only waterbody that would be affected by the Terminal Expansion.

#### Dredging

The primary impact on the SNWW from construction of the Terminal Expansion would be dredging about 368,750 yd<sup>3</sup> of sediment to provide access to the Supply Dock and access channel. During operation of the Terminal Expansion, the Supply Dock and access channel would undergo maintenance dredging of the area in accordance with its pending COE permit.

Depending on conditions of the shoreline at the time of construction, Golden Pass would construct the shoreline protection system using upland-based construction methods, marine-based construction methods, or a combination of the two methods. Should Golden Pass use marine-based methods, dredging of temporary float channels would be required to allow marine equipment access to the construction site. The temporary float channels would require dredging of about 86,700 yd<sup>3</sup> of sediment from a 13.1 acre area within in the SNWW.

Annual maintenance dredging would continue to be conducted at the existing Ship Slip as authorized by Golden Pass' existing COE permit. During construction of the Terminal Expansion, Golden Pass would use dredge spoil from maintenance dredging of the existing Ship Slip for wetland mitigation (see section 4.4). Following this one-time use of dredge spoil, any other maintenance dredging materials from the existing Ship Slip would be disposed of at existing DMPAs, as required in Golden Pass' existing COE permit. We previously assessed impacts associated with construction of the Golden Pass Import Terminal in our EIS for the existing terminal (FERC, 2005). Dredging of the Supply Dock and associated access channels would result in impacts similar to those that occurred during construction of the existing terminal's Ship Slip by Golden Pass and during routine maintenance dredging of the SNWW by the COE. Construction of the Supply Dock and access channels would require dredging of about 455,450 yd<sup>3</sup> of sediment.

Because the sediments within the area are anticipated to consist primarily of fine particles, dredging would result in temporary and local suspension of sediments and minor increased turbidity levels that would be limited to the period of dredging and a short time after dredging ceases. Golden Pass would use a hydraulic cutterhead dredge or conduct a dry excavation with limited hydraulic cutterhead dredge below the existing waterline. Golden Pass would adhere to measures outlined in FERC's Plan and Procedures to minimize impacts due to dredging. This impact would be temporary, and turbidity would return to pre-dredging levels soon after dredging is completed.

Although it is possible that sediments dredged during construction could contain contamination, the sediments would not be different from those dredged during construction of the existing terminal, which were not found to contain contaminants. Further, Golden Pass' chemical analysis of water and sediments at the existing Ship Slip show that contaminants are not present or are present at concentrations low enough to result in no adverse effects to aquatic biota. Golden Pass would obtain the necessary permits to conduct construction and maintenance dredging of the Supply Dock, which include COE Section 10 and Section 404 Permits, a Section 401 Water Quality Certification, and a Coastal Zone Consistency Determination through the Texas Railroad Commission (Texas RRC) (see table 1.5-1). The permits would provide Golden Pass with authorization from both agencies to perform dredging and filling of coastal waterbodies, assuming that all other authorizations, certificates, and permits are obtained for the Project. Golden Pass would dispose of dredged sediments from construction of the Supply Dock, access channel, and any temporary float channels in designated DMPAs in accordance with the COE's Section 404 Permit, if granted, and approval from the manager and/or owners of the facilities. Appendix I includes Golden Pass' DMMP.

As part of the original EIS for the Golden Pass Import Terminal, we also assessed potential impacts related to terminal operations, including the use of LNG carriers (including traffic, transit, and ballast discharges, and LNG spills) (FERC, 2005). Because Golden Pass is not proposing to change the frequency or size of LNG vessels analyzed in the EIS for the Golden Pass Import Terminal, impacts associated with these activities generally are not expected to change. Unless there is the potential for an impact to increase, it is not addressed in this EIS. We note that ballast water management would be modified and that ballast water management requirements have changed since those reviews were conducted. Future LNG export would require that LNG carriers discharge ballast water while loading LNG instead of taking in ballast during LNG offloading. Based on current requirements, LNG captains would comply with revised ballast water requirements, found in 33 CFR 151 (Vessels Carrying Oil, Noxious Liquid Substances, Garbage, Municipal or Commercial Waste and Ballast Water), 46 CFR Subpart 162.060 (Ballast Water Management

Systems), and the Coast Guard's Navigation and Vessel Inspection Circular 07-04. Effective December 19, 2013, the EPA promulgated an NPDES Vessel General Permit that sets numeric limits for ballast water discharges from certain large commercial vessels and includes maximum discharge limitations for biocides and residues. Additional information about Project-related ballast water is provided in section 4.6.2.

Barges and support vessels would deliver large equipment and construction materials to the Supply Dock, which would increase ship traffic in the SNWW and the Gulf Intracoastal Waterway. Golden Pass estimates that construction would require up to a maximum of three deliveries per day (see section 4.9.6.1). Barge traffic may result in some suspension of bottom sediments and temporarily increase turbidity. The increase in turbidity could result in localized, minor, and temporary decreases in dissolved oxygen.

Barges and support vessels would take in cooling water for vessel boilers while in transit and discharge the cooling water after use. The cooling water would be circulated in a closed system and would not have chemicals added to it. Discharge of the cooling water potentially would result in highly localized and temporary increases in water temperature in the SNWW and ship channel. Based on an analysis on larger marine vessels conducted for a similar project, however, the temperature change would be insignificant (generally would dissipate to a change of temperature of 1°C or less warmer than ambient conditions 15 to 30 meters from the discharge source) given the total volume of water within the discharge area (FERC, 2005).

#### Hydrostatic Testing

Golden Pass would hydrostatically test the piping and LNG storage tanks to verify the integrity of these facilities prior to placing them in service. Water also would be used to flush pipes in order to remove any solids that may be present inside of them. As described earlier, water used for hydrostatic testing as well as pipe flushing would come from the same source and would be obtained from a municipal line or purchased raw water. No additives, such as a biocide or oxygen scavenger, would be used during hydrostatic testing or pipe flushing activities. After completion of hydrostatic testing, Golden Pass would discharge the hydrostatic test water to the SNWW in accordance with FERC's Plan and Procedures to minimize impacts on surface water. Hydrostatic testing of the Terminal Expansion piping and tanks would not result in a significant impact on surface waters.

#### Firewater Pump Testing

Firewater pumps would be tested weekly. The primary firewater system would use water withdrawn from an onsite freshwater storage tank containing water supplied by the Port Arthur Water Treatment Department. The secondary, or backup, firewater system would withdraw water from the SNWW. Water from the secondary firewater system would be withdrawn in accordance with a TCEQ-issued Water Use Permit (Permit Number 12486A) that allows for withdrawal of up to 6,000 gpm and 45-acre-feet per year. Golden Pass anticipates withdrawing water from the SNWW at a rate of about 4,500 to 6,000 gpm for a maximum time period of 30 minutes for each test.

Golden Pass does not anticipate the need to chemically treat water used for firewater pump testing. Test water would be discharged into the SNWW at a location near the uptake point. Potential impacts on surface water associated with firewater pump testing would be largely associated with the withdrawal and subsequent discharge of surface water. However, because of the relatively small amount of water being withdrawn and because the water would be returned to its source following completion of testing, significant impacts on surface waters would not occur.

### Propeller Wash

Propeller action from boats being used during Project construction could temporarily suspend and resuspend material that has entered the waterbody as a result of shoreline erosion. This could lead to localized increases in turbidity in the SNWW; however, these minor impacts would be limited to the duration of in-water construction activities.

### Erosion and Runoff

Construction of the Terminal Expansion would permanently reduce the amount of pervious surface, thereby increasing the potential frequency and volume of stormwater runoff into the SNWW. Stormwater runoff can pick up debris, chemicals, dirt, and other pollutants before entering directly to a waterbody (EPA, 2013b). Construction of the Supply Dock also would require dredging of 305,750 yd<sup>3</sup> from a 13.2-acre area of the SNWW, which would cause temporary increases in erosion and sedimentation in the immediate vicinity of construction activities. Following construction, the shoreline would be stabilized with an armored shoreline protection system to prevent post-construction erosion.

To minimize impacts on the SNWW from potential erosion and sedimentation due to land disturbance during construction and operation of the Terminal Expansion, Project activities would be conducted in accordance with FERC's Plan and Procedures and all Texas and Louisiana stormwater regulations and permitting requirements. As mandated by these plans, Golden Pass would implement measures, including installation and maintenance of all necessary erosion and sedimentation control structures, to avoid impacts on the SNWW. Four new water outfalls would be installed along the SNWW's shoreline east of the Supply Dock to manage stormwater and wastewater flow at the facility and minimize erosion, in accordance with the Golden Pass SPCC Plan. With implementation of these measures and Golden Pass' design of the Project, erosion and runoff from construction and operation would be minimized and not significant.

### Inadvertent Spills

Water quality of the SNWW could be adversely affected by a spill, leak, or other release of hazardous materials during construction. Transport of released hazardous materials into the SNWW by stormwater runoff would degrade water quality and could affect aquatic organisms. To minimize the potential for a release of hazardous materials and to avoid or minimize the impacts of a release if one were to occur, Golden Pass would adhere to the measures outlined in FERC's Plan and Procedures, and it's SPCC Plan during construction and operation of the Terminal Expansion. Construction of the Supply Dock would require refueling of water-based equipment located in the SNWW. To accomplish this task, Golden Pass has requested a variance to Section VI.A.1.d of the FERC Procedures to allow for refueling to occur within 100 feet of a waterbody (see table 4.3-4). Golden Pass would conduct all refueling activities of water-based equipment in compliance with Coast Guard protocols to prevent fuel used for the Project activities from entering waterbodies or wetlands. Construction activities at the Terminal Expansion site, including the Supply Dock, also would require storage of hazardous materials within 100 feet of waterbodies (section VI.A.1.e of the FERC Procedures). Golden Pass has requested a variance to this section of the FERC Procedures that would allow, upon inspection and approval by an EI, for the storage of hazardous materials in staging and laydown areas in wetlands that have been filled and converted to industrial-use land. The requested variance also would allow for fuel barges to be docked at the Supply Dock during construction activities. Once construction of the storm protection levee system is complete, EI inspection and approval of the storage of hazardous materials within the levee system would no longer be required, because the levee would prevent potential runoff from entering the adjacent SNWW. Details of the storm protection levee system are provided in section 2.2.1.7. Table 4.3-4 lists Golden Pass' requested deviations from the FERC Procedures and FERC's approval or denial of those requests. Wetland impacts are more thoroughly discussed in section 4.4.

**TABLE 4.3-4**

**Golden Pass' Requested Deviations from the FERC Procedures**

Reference	Description	Proposed Revision	Relevant Project Component(s)	FERC Staff Conclusion
Section V.B.1	In-stream work, except that required to install or remove bridges should occur during June 1 and November 30 for coolwater and warmwater fisheries.	Year-round Project activity would be conducted in the SNWW and PUB areas of the existing terminal.	Terminal Expansion	<b>Justified.</b> Using the SNWW year-round for construction and operation of the Terminal Expansion would shorten the duration of construction activities and allow for maintenance dredging of the Supply Dock, as necessary.
Section V.B.2	All extra work areas should be at least 50 feet from the water's edge, except where the adjacent upland consists of cultivated or rotated cropland or other disturbed land.	Extra workspace would be within 50 feet of the SNWW.	Terminal Expansion	<b>Justified.</b> There are insufficient upland areas within the existing terminal boundaries to provide the extra workspace needed for construction. In addition, the potential locations for extra workspaces are constrained by the need to collocate and integrate with the existing terminal infrastructure.
Section V.C	All waterbody banks should be returned to pre-construction contours or to a suitable angle of repose, as approved by the Environmental Inspector	The armored shoreline protection structure at the Supply Dock would be maintained during Project construction and operations.	Terminal Expansion	<b>Justified.</b> The armored shoreline protection system would minimize shoreline erosion that would occur if it were not installed. It also would provide greater than 25-year storm protection.
Section V.D.2	Herbicides or pesticides should not be used in or within 100 feet of a waterbody.	The use of herbicides or pesticides would be permitted within 100 feet of the SNWW at the Terminal Expansion site and within 100 feet of impoundments/ponds at the compressor station sites.	Terminal Expansion; Pipeline Expansion and aboveground facilities	<b>Justified.</b> The areas for which the variance is requested are within the proposed storm protection levee system, which would prevent any potential runoff from entering the SNWW.  Proposed compressor stations would be within 100 feet of a waterbody. Use of herbicides would be in accordance with BMPs as directed by the Environmental Inspection onsite.

TABLE 4.3-4 (continued)

Golden Pass' Requested Deviations from the FERC Procedures

Reference	Description	Proposed Revision	Relevant Project Component(s)	FERC Staff Conclusion
Section VI.A.1.d	All equipment should be parked overnight and/or fueled at least 100 feet from a waterbody or in an upland area at least 100 feet from a wetland boundary.	Refueling of water-based equipment would take place within 100 feet of the SNWW.	Terminal Expansion	<b>Justified.</b> Construction of the Supply Dock would require refueling of water-based equipment within 100 feet of the SNWW and adjacent wetlands. Refueling activities within 100 feet of the SNWW are discussed in section 4.3.2.2 of this EIS.
Section VI.A.1.e	Hazardous materials, including fuels, lubricating oils, and chemicals should not be stored within 100 feet of a wetland, waterbody, or designated municipal watershed area.	An Environmental Inspector must inspect and approve the storage of hazardous materials within 100 feet of a wetland or waterbody at the Terminal Expansion, unless the storage area is within the storm protection levee.	Terminal Expansion	<b>Justified.</b> Project-related activities at the Supply Dock would require that fuel barges be docked in the SNWW and within 100 feet of onshore wetlands. Additional discussion of this proposed variance is provided in section 4.3.2.2 of this EIS.

TABLE 4.3-4 (continued)

Golden Pass' Requested Deviations from the FERC Procedures

Reference	Description	Proposed Revision	Relevant Project Component(s)	FERC Staff Conclusion
Section VI.A.3	The construction right-of-way width should be limited to 75 feet or less in wetlands, unless prior written approval of the Director has been provided in areas where topographic conditions or soil limitations require that the width be expanded beyond 75 feet.	The construction right-of-way width should be 75 or less within wetlands, except for the following wetlands for which wider right-of-way widths are being requested: W-106 (115 feet); W-107 (115 feet); W-108 (115 feet); W-109 (150 feet [rice field]); W 110 (100 feet); W-111; W-112 (150 feet [rice field]); W-115 (100 feet); W-117 (100 feet); W-118 (100 feet); W-119 (100 feet); W-123 (100 feet); W-124 (115 feet); W-125 (115 feet); W-127 (115 feet); W-152 (115 feet); and one wetland identified through 2014 aerial imagery due to lack of survey permission (100 feet).	Pipeline Expansion and aboveground facilities	<b>Justified.</b> Soil conditions for the identified wetlands require extra workspace to maintain slope stability of the pipeline trench, contain trench spoil within the temporary construction right-of-way, and segregate and store topsoil.

TABLE 4.3-4 (continued)

Golden Pass' Requested Deviations from the FERC Procedures

Reference	Description	Proposed Revision	Relevant Project Component(s)	FERC Staff Conclusion
Section VI.A.6	Aboveground facilities should not be within wetlands, except where the location of such facilities outside of wetlands would prohibit compliance with the U.S. Department of Transportation.	Portions of the Terminal Expansion, MP 1 Compressor Station, MP 33 Compressor Station, and MP 66 Compressor Station facilities would be sited within wetlands.	Terminal Expansion; Pipeline Expansion and aboveground facilities	<p><b>Justified for the Terminal Expansion and MP 1 Compressor Station.</b> The applicant would site the Terminal Expansion facilities within the existing terminal's footprint to minimize impacts as well as collocate and integrate with existing terminal infrastructure. There are limited upland areas within and adjacent to the existing terminal's property. In addition, the Terminal Expansion's location was selected, in part, to comply with U.S. Department of Transportation regulations.</p> <p>Similarly, Golden Pass would site the MP 1 Compressor Station facilities partially within wetlands in order to collocate and integrate with existing Golden Pass Pipeline infrastructure.</p> <p><b>Not Justified</b> for the MP 33 and MP 66 Compressor Stations. See discussion and recommendation in section 4.4.2.2.</p>
Section VI.B.1.a	All extra work areas should be at least 50 feet from wetland boundaries, except where the adjacent uplands consist of cultivated or rotated cropland or other disturbed land.	The HDD extra work area at approximate MP 65 of the existing Golden Pass Pipeline, extra work area for the compressor stations and interconnections, and extra work areas for the Terminal Expansion that are located outside of the existing Golden Pass Import Terminal would be within 50 feet of wetlands.	Terminal Expansion; Pipeline Expansion and aboveground facilities	<p><b>Justified.</b> There are limited upland areas within and adjacent to the existing terminal's property. Therefore, extra workspace would be located within a wetland.</p> <p>Similarly, there are limited upland areas adjacent to the proposed compressor station sites, which were selected to make use of existing infrastructure to minimize the overall Project footprint.</p>



Reference	Description	Proposed Revision	Relevant Project Component(s)	FERC Staff Conclusion
Section VI.B.1.d	The only access roads, other than the construction right-of-way, that can be used in wetlands are those existing roads that can be used with no modifications or improvements, other than routine repair, and no impact on the wetland.	Access roads associated with construction and operation of the Terminal Expansion, MP 1, MP 33, and MP 66 Compressor Stations would result in impacts on wetlands.	Terminal Expansion; Pipeline Expansion and aboveground facilities	<b>Justified.</b> Existing access roads leading to the Terminal Expansion, MP 1, MP 33, and MP 66 Compressor Station facilities would require improvements to provide a safe work area. The improved use of existing roads could minimize potential impacts on wetlands and is needed to collocate and integrate with existing Golden Pass infrastructure.
Section VI.B.4	Trench dewatering should be done in a manner that does not cause erosion and does not result in silt-laden water flowing into any wetland.	EI-monitored discharge of water from trench dewatering activities would be permitted in wetlands.	Terminal Expansion; Pipeline Expansion and aboveground facilities	<b>Justified.</b> There is not adequate upland space for trench dewatering discharge at the proposed Terminal Expansion site or at the MP 1 Compressor Station and associated suction header.  There are limited upland areas within and adjacent to the existing terminal's property. Therefore, trench dewatering would occur within a wetland.
Section VI.C.2	Wetlands should be restored to their pre-construction contours to maintain the original wetland hydrology.	Wetlands that are filled during Project construction would remain filled post-construction and would not be returned to their previous contours.	Terminal Expansion; Pipeline Expansion and aboveground facilities	<b>Justified.</b> Wetlands that would be permanently filled that are not part of the proposed facilities' footprint would be used as construction laydown areas. These areas would be used for 5 years during LNG export facility construction. The filled laydown areas are required to create a safe, stable working surface and would not be restored following construction.  Wetlands would be filled as part of construction of the proposed compressor stations. These filled wetlands would be mitigated through compensatory mitigation in the COE 404/401 permitting process.

TABLE 4.3-4 (continued)

Golden Pass' Requested Deviations from the FERC Procedures

Reference	Description	Proposed Revision	Relevant Project Component(s)	FERC Staff Conclusion
Section VI.C.6	Until wetland restoration plan is developed and/or implemented, the right-of-way should be temporarily revegetated with annual ryegrass at a rate of 40 pounds/acre.	Wetlands within the proposed Terminal Expansion area would remain filled following construction and would not be reseeded.	Terminal Expansion; Pipeline Expansion and aboveground facilities	<b>Justified.</b> Wetlands at the Terminal Expansion site that would be permanently filled and used as construction laydown areas would be used for 5 years during LNG export facility construction. The filled laydown areas are required to create a safe, stable working surface and would not be restored following construction.  Wetlands would be filled as part of construction of the proposed compressor stations. These filled wetlands would be mitigated through compensatory mitigation in the COE 404/401 permitting process.
Section VI.D.1	Routine vegetation mowing or clearing should not be conducted over the full width of the permanent right-of-way in wetlands. However, to facilitate periodic corrosion and leak surveys, a corridor centered on the pipeline and up to 10 feet wide may be cleared at a frequency necessary to maintain the 10-foot corridor in an herbaceous state. In addition, trees within 15 feet of the pipeline with roots that could compromise the integrity of the pipeline coating may be selectively cut and removed from the permanent right-of-way.	Routine vegetation mowing would be permitted in wetland areas around security fences, within property boundaries, and in other areas, as necessary, for safety purposes.	Terminal Expansion	<b>Justified.</b> The long growing season in the Gulf Coast would require routine mowing both inside and outside of the perimeter fencing. In accordance with Coast Guard regulations, a distance of 25 feet from the fence's edge outside of the perimeter fence would be mowed to ensure safe facility operations.

TABLE 4.3-4 (continued)				
Golden Pass' Requested Deviations from the FERC Procedures				
Reference	Description	Proposed Revision	Relevant Project Component(s)	FERC Staff Conclusion
Section VI.D.2	Herbicides or pesticides should not be used in or within 100 feet of a wetland, except as allowed by the appropriate federal or state agency.	The use of herbicides or pesticides would be permitted within 100 feet of a wetland and within permanently filled wetlands.	Terminal Expansion; Pipeline Expansion and aboveground facilities	<p><b>Pending approval from COE and applicable state agencies.</b> Wetlands at the Terminal Expansion site that would be permanently filled and used as construction laydown areas would be used for 5 years during LNG export facility construction. The filled laydown areas are required to create a safe, stable working surface and would not be restored following construction. Herbicides would be used to maintain these facilities.</p> <p>The controlled use of herbicides or pesticides at the compressor station and interconnect sites adjacent to wetlands would be needed to maintain safe operations.</p>

With implementation of the measures discussed above and in table 4.3-4, impacts on surface water resources from spills at the Terminal Expansion would be minimized to the extent practicable.

## **Pipeline Expansion**

### Open-Cut Crossing

Construction of the Calcasieu Loop would require crossing one intermediate and two minor waterbodies. All waterbodies that would be crossed are man-made ditches, two of which (the minor waterbodies) serve as drainage ditches on both sides of a roadway (see table 4.3-3). Golden Pass would cross the intermediate waterbody using the wet open-cut method (see section 2.6.3.1). The crossing method that would be used at the two minor waterbodies is not yet determined. However, as stated in section 4.3.2.1, the FERC has recommended that Golden Pass select an appropriate crossing method prior to the end of the comment period.

Potential impacts on surface water from the open-cut crossings would be short term and would occur only during construction activities. Impacts would result from temporary suspension of sediments during the open-cut crossing. The extent of the impact would depend on sediment load, water velocity, turbidity, bank composition, and sediment particle size. These factors would determine the density and downstream extent of sediment migration. In-water construction could dislodge and transport channel bed sediments and alter stream contours. Changes in bottom contours could alter stream dynamics and increase downstream erosion or deposition, depending on circumstances. Turbidity resulting from resuspension of sediments from in-stream construction or erosion of cleared stream bank right-of-way areas could reduce light penetration and photosynthetic oxygen production. In-stream work also could introduce chemical and nutrient pollutants from sediments, if present. Resuspension of deposited organic material and inorganic sediments could cause an increase in biological and chemical use of oxygen, potentially resulting in a decrease of dissolved oxygen concentrations in the affected area. Lower dissolved oxygen concentrations could cause temporary displacement of motile organisms, and non-motile organisms could suffer mortality within the affected area.

Golden Pass would follow the measures contained in FERC's Plan and Procedures for the waterbody crossing to ensure that adequate water flow rates are maintained at the crossing locations and interruption of downstream uses are prevented. To reduce potential turbidity during the open-cut crossings, Golden Pass would conduct all construction activities from the banks of the ditch. Once the pipeline is installed, Golden Pass would restore the stream banks to pre-construction contours. Golden Pass would complete in-stream construction activities within the 24-hour window, as required by the FERC Procedures.

Clearing and grading of stream banks would expose soil to erosion and would reduce riparian vegetation along the cleared sections of the affected waterbodies. The use of heavy equipment for construction could cause compaction of near-surface soils, an effect that could result in increased runoff into surface waters. The increased runoff could transport additional sediment into the waterbodies, resulting in increased turbidity levels and sedimentation rates in the receiving waterbody.

Golden Pass would implement the following measures to minimize impacts on stream banks:

- clearing only the vegetation needed for safe construction of the pipeline;
- installing and maintaining erosion and sediment control structures;
- restoring waterbody banks to pre-construction contours; and
- conducting post-construction monitoring to ensure successful revegetation.

In addition, dust generated from vehicular and equipment traffic could increase sedimentation of adjacent waterbodies. To mitigate this effect, Golden Pass proposes to use about 8,000 gallons of water a day, as needed, from commercially available sources for dust control during construction of the Pipeline Expansion and aboveground facilities. This action would minimize the movement of soil from wind.

#### Pipe Storage and Contractor Yard

As previously stated, no waterbodies are located on the proposed pipe storage and contractor yard site in Orange County, Texas; therefore, no impacts on surface water resources would occur at this site from Project activities.

#### Hydrostatic Testing

Golden Pass would hydrostatically test the pipeline and the piping associated with the aboveground facilities before initiating operation, in accordance with the pipeline safety regulations identified in 49 CFR 192. Hydrostatic testing of the pipeline (including the HDD string) and piping in aboveground facilities would require about 8,295,000 gallons of water,<sup>22</sup> for which Golden Pass would use municipal or raw water. Additives, such as biocides or oxygen scavengers, would not be used during hydrostatic testing.

Hydrostatic test water would be discharged in vegetated upland areas through energy dissipation devices to reduce the velocity of the discharge and minimize erosion. Therefore, we believe that the use and discharge of hydrostatic test water would not result in a significant impact on surface waters. In addition, Golden Pass would comply with the stipulations regarding hydrostatic test water discharge included in its LDEQ discharge permit (including sampling and testing prior to discharge), which would further reduce the potential for impacts.

#### Inadvertent Spills

To avoid or minimize the potential impacts of inadvertent spills from refueling of vehicles and storage of fuel, oil, or other hazardous materials near surface waters, Golden Pass would implement the measures provided in its SPCC Plan (see appendix F). These measures include restricting refueling and storage of potentially hazardous materials to upland areas at least 100 feet from waterbodies, where practicable, and provisions to handle stormwater that may carry spilled materials. If a spill were to occur, immediate downstream users of the water could experience degradation in water quality, and acute and chronic toxic effects on aquatic organisms could occur. However, Golden Pass would not store large volumes of fuel, oil, or other hazardous materials along the pipeline right-of-way; and it is not likely that significant long-term impacts would result if a spill were to reach a waterbody.

### **4.3.3 Alternative Measures to the FERC's Procedures**

Golden Pass requested several deviations from the FERC Procedures. Our evaluation and conclusions for the proposed deviations to the FERC Procedures are presented in table 4.3-4.

---

<sup>22</sup> The total hydrostatic test volumes of water were calculated using conservative measures by assuming that the approximate volumes needed to test the Tennessee Gas Interconnect and the Transco Interconnect is 10,000 gallons each, despite estimates that the approximate volumes would be less than 10,000 gallons each.

## 4.4 WETLANDS

Wetlands are areas that are inundated or saturated by surface water or groundwater at a frequency and duration sufficient to support, and under normal circumstances do support, a prevalence of vegetation typically adapted for life in saturated soil conditions (EPA, 2012c). Wetlands can be a source of substantial biodiversity and serve a variety of functions that include providing wildlife habitat, recreational opportunities, flood control, and naturally improving water quality.

Section 404 of the CWA establishes standards to evaluate and reduce total and net impacts on wetlands under the regulatory jurisdiction of the COE. These standards require avoidance of wetlands where possible and minimization of disturbance where impacts are unavoidable, to the degree practicable. Golden Pass also must demonstrate that it has taken appropriate and practicable steps to minimize wetland impacts in compliance with the COE's Section 404(b)1 guidelines that restrict discharges of dredged or fill material where less environmentally damaging alternatives exist. The COE New Orleans, Louisiana, and Galveston, Texas District Offices have authority under Section 404 of the CWA to review and issue permits for Project-related activities that would result in discharge of dredged or fill material into waters of the United States, including wetlands. Golden Pass submitted a Section 404/Section 10 Permit application to the COE on July 7, 2014. The COE's jurisdictional determination is pending.

Texas and Louisiana do not have their own wetland protection laws or programs; instead, they are required to conduct a Section 401 certification review of COE Section 404 Permit applications to determine whether a project would comply with the state's water quality standards. In addition to being regulated by the COE, wetlands located within Texas and Louisiana coastal zones are regulated by the Texas CMP and the LDNR Coastal Resources Program (TCEQ, 2004; ASWM, 2011). The Project area within Jefferson and Orange Counties is located entirely within the Texas Coastal Zone (TCMP, 2012). Under Section 307 of the CZMA, the TGLO would coordinate with the Texas RRC to develop a Consistency Determination for the Project. The Project is not sited on and would not affect any wetlands in Louisiana's Coastal Zone (COE, 2014). Golden Pass must comply with all CWA conditions of applicable permits issued by the COE, the TGLO, and the LDEQ, including the provisions of Section 307 of the CZMA and required compensatory wetland mitigation.

### 4.4.1 Existing Environment

Golden Pass reviewed available NWI maps and soil surveys, and conducted wetland field surveys within the Project footprint in 2013—including the Terminal Expansion facilities, the Pipeline Expansion construction right-of-way, access roads, the ATWS, and aboveground facilities—to delineate wetland boundaries in accordance with the requirements of the *Corps of Engineers Wetland Delineation Manual* (Environmental Laboratory, 1987). In addition, Golden Pass conducted qualitative assessments for each identified wetland based on the COE's five ecological parameters: quality of wetland vegetation, soils, hydrology, presence of plant and animal species of concern, and level of disturbance within the wetland and adjacent areas. Data were collected and recorded through field notes, through aerial photographs, and by using a geographic positioning system. The following data were collected:

- wetland type and function;
- beginning and ending milepost locations for construction easements;
- length of each wetland crossing;
- width of permanent or temporary easements;
- additional temporary workspace area, if needed; and
- boundaries of ancillary facilities.

Four types of wetlands were identified within the Project area. Table 4.4.1-1 lists the Cowardin classification for wetlands occurring within the Project area and includes a description of each.

<b>TABLE 4.4.1-1</b>	
<b>Classifications of Wetlands in the Golden Pass LNG Export Project Area</b>	
Palustrine Emergent Marsh (PEM)	Vegetation standing in up to 3 feet of water; dominated by erect, rooted herbaceous freshwater hydrophytic vegetation
Palustrine Scrub-Shrub (PSS)	Areas dominated by woody vegetation less than 20 feet (6 meters) tall; woody shrub component consisting of shrubs and small trees
Palustrine Forested (PFO)	Areas dominated by woody vegetation less than 20 feet (6 meters) tall
Estuarine Emergent Wetland (EEM)	Wetlands adjacent to the subtidal area that are exposed and flooded by tides periodically; includes wetlands not normally flooded associated with the splash zone
Source: Cowardin et al., 1979	

Using the criteria previously described, Golden Pass identified a total of 66 wetland crossings. Wetland impacts would occur at both the Terminal Expansion and Pipeline Expansion sites. In some cases, the Project would include multiple crossings of the same wetland. The applicant would conduct 19 crossings using the open-cut method, and 8 crossings using HDD methods. The remaining 39 wetland crossings would be filled and permanently converted to industrial-use land. Table 4.4.1-2 provides the number of wetland crossings by anticipated crossing method and wetland type. Appendix J provides additional information on proposed wetland crossings, including wetland IDs, crossing locations, temporary and permanent acreages of impacts, and the proposed crossing methods. There are no wetlands at the proposed pipe storage and contractor yard; therefore, the yard is not discussed further in this section.

<b>TABLE 4.4.1-2</b>					
<b>Number of Wetland Crossings by Wetland Type and Crossing Method for the Golden Pass LNG Export Project</b>					
	<b>PEM <sup>a</sup></b>	<b>PSS</b>	<b>PFO <sup>b</sup></b>	<b>EEM</b>	<b>TOTAL</b>
Open-cut crossing	15	2	2	0	19
HDD method	8	0	0	0	8
Permanent conversion to industrial-use land	32	3	3	1	39
<b>TOTAL</b>	<b>55</b>	<b>5</b>	<b>5</b>	<b>1</b>	<b>66</b>
<b>Abbreviations:</b>					
PEM = Palustrine Emergent		PSS = Palustrine Scrub-Shrub			
PFO = Palustrine Forested		EEM = Estuarine Emergent			
<b>Notes:</b>					
<b>a</b>	Includes farmed PEM (PEMf) and excavated PEM (PEMx) wetlands.				
<b>b</b>	Includes excavated PFO (PFOx) wetlands.				

## 4.4.2 Wetland Impacts and Mitigation

### 4.4.2.1 Terminal Expansion

Construction of the Terminal Expansion would require 23 wetland crossings for siting of new Project facilities and to realign an existing access road. Table 4.4.2-1 lists temporary and permanent impacts on wetlands that would occur during construction and operation of the Project. Construction would affect 381.4 acres of wetlands at the site, and 372.5 acres would be permanently filled for Project operations. The remaining 8.9 acres would be restored to pre-construction contours and allowed to revegetate naturally.

TABLE 4.4.2-1										
Wetlands Affected by the Golden Pass LNG Export Project <u>a</u>										
Project Component	Acres of Wetland Type Affected <u>b, c</u>									
	Wetland Classification									
	PEM <u>d</u>		PSS		PFO <u>e</u>		EEM		Total	
	Temp <u>f</u>	Perm <u>g</u>	Temp	Perm	Temp	Perm	Temp	Perm	Temp	Perm
<b>Terminal Expansion</b>										
Terminal Expansion	377.7	368.9	1.2	1.2	0.4	0.4 <u>h</u>	0.2	0.1	379.4	370.5
Access Roads	2.0	2.0	0.0	0.0	0.0	0.0	0.0	0.0	2.0	2.0
ATWS	0.0	0.0	0.0	0.0	0.0	0.0	0.0	0.0	0.0	0.0
<b>Terminal Expansion Subtotal</b>	<b>379.7</b>	<b>370.9</b>	<b>1.2</b>	<b>1.2</b>	<b>0.4</b>	<b>0.4 <u>h</u></b>	<b>0.2</b>	<b>0.1</b>	<b>381.4</b>	<b>372.5</b>
<b>Pipeline Expansion</b>										
Calcasieu Loop	4.4	2.0 <u>i</u>	0.1	0.0	0.1	0.0 <u>i</u>	0.0	0.0	<b>4.5</b>	<b>2.0 <u>i</u></b>
Access Roads	0.0 <u>i</u>	0.0	0.0	0.0	0.0	0.0	0.0	0.0	0.0 <u>i</u>	0.0
ATWS	0.0 <u>i</u>	0.0	0.0	0.0	0.0	0.0	0.0	0.0	0.0 <u>i</u>	0.0
MP 1 Compressor Station	7.3	7.3	0.0	0.0	0.0	0.0	0.0	0.0	7.3	7.3
Access Roads	0.1	0.1	0.0	0.0	0.0	0.0	0.0	0.0	0.1	0.1
ATWS	0.6	0.0	0.0	0.0	0.0	0.0	0.0	0.0	0.6	0.0
NGPL Interconnection	3.3	1.3	0.0	0.0	0.0	0.0	0.0	0.0	3.3	1.3
Access Road	0.0	0.0	0.0	0.0	0.0	0.0	0.0	0.0	0.0	0.0
ATWS	0.2	0.0	0.0	0.0	0.0	0.0	0.0	0.0	0.2	0.0
MP 33 Compressor Station	0.3	0.3	0.0	0.0	0.0 <u>i</u>	0.0 <u>i</u>	0.0	0.0	0.3	0.3
Access Roads	0.0 <u>i</u>	0.0 <u>i</u>	0.0	0.0	0.0	0.0	0.0	0.0	0.0 <u>i</u>	0.0 <u>i</u>
ATWS	0.0	0.0	0.0	0.0	0.0	0.0	0.0	0.0	0.0	0.0
Texoma Interconnection <u>j</u>	0.1	0.1	0.0	0.0	0.0	0.0	0.0	0.0	0.1	0.1
Tennessee Gas Interconnection <u>k</u>	0.0	0.0	0.0	0.0	0.0	0.0	0.0	0.0	0.0	0.0
Access Roads	0.0 <u>i</u>	0.0 <u>i</u>	0.0	0.0	0.0	0.0	0.0	0.0	0.0 <u>i</u>	0.0 <u>i</u>
ATWS	0.3	0.0	0.0	0.0	0.0	0.0	0.0	0.0	0.3	0.0
MP 66 Compressor Station	0.1	0.1	0.0	0.0	0.0	0.0	0.0	0.0	0.1	0.1
Access Roads	0.0 <u>i</u>	0.0 <u>i</u>	0.0 <u>i</u>	0.0 <u>i</u>	0.0	0.0	0.0	0.0	0.0 <u>i</u>	0.0 <u>i</u>
ATWS	0.0	0.0	0.0	0.0	0.0	0.0	0.0	0.0	0.0	0.0



TABLE 4.4.2-1 (continued)										
Wetlands Affected by the Golden Pass LNG Export Project <u>a</u>										
Project Component	Acres of Wetland Type Affected <u>b, c</u>									
	Wetland Classification									
	PEM <u>d</u>		PSS		PFO <u>e</u>		EEM		Total	
	Temp <u>f</u>	Perm <u>g</u>	Temp	Perm	Temp	Perm	Temp	Perm	Temp	Perm
TETCO Interconnection <u>j</u>	0.1	0.1	0.0	0.0	0.0	0.0	0.0	0.0	0.1	0.1
Transco Interconnection <u>j</u>	0.0	0.0	0.0	0.0	0.0	0.0	0.0	0.0	0.0	0.0
<b>Pipeline Expansion Subtotal</b>	<b>16.8</b>	<b>11.4</b>	<b>0.1</b>	<b>0.0</b>	<b>0.1</b>	<b>0.0 <u>i</u></b>	<b>0.0</b>	<b>0.0</b>	<b>17.0</b>	<b>11.4</b>
Pipe Storage and Contractor Yard <u>j</u>	0.0	0.0	0.0	0.0	0.0	0.0	0.0	0.0	0.0	0.0
<b>TOTAL</b>	<b>396.5</b>	<b>382.3</b>	<b>1.2</b>	<b>1.2</b>	<b>0.5</b>	<b>0.4</b>	<b>0.2</b>	<b>0.1</b>	<b>398.4</b>	<b>383.9</b>

Notes:

a The numbers in this table have been rounded for presentation purposes. As a result, the totals may not reflect the sum of the addends.

b Includes impacts associated with access roads and the ATWS.

c Does not include wetland impacts on areas currently being used for the existing Golden Pass Pipeline.

d Includes farmed PEM (PEMf) and excavated PEM (PEMx) wetlands.

e Includes excavated PFO wetlands (PFOx).

f Temp = temporary

g Perm = permanent

h Less than 0.05 acre of the impacts on PFO wetlands would not be permanently filled. This acreage is not represented due to rounding.

i Acreage of impacts was greater than 0.00 but less than 0.05 acre.

j No impacts on wetlands from the use of access roads or ATWS would occur at this site.

k All impacts on wetlands at the Tennessee Gas Interconnection site would occur from the use of access roads and ATWS.

Because 372.5 acres of wetlands would be permanently impacted, we conclude that the adverse impacts on wetland resources at the Terminal Expansion site would be significant without mitigation. Permanent wetland impacts would be mitigated through the COE compensatory mitigation process. Compensatory wetland mitigation for the Terminal Expansion is discussed later in this section.

#### 4.4.2.2 Pipeline Expansion

Construction of the Pipeline Expansion (i.e., the Calcasieu Loop, compressor stations, and interconnections) would require 43 wetland crossings, affecting 17.0 acres of wetlands. Of these impacts, 11.4 acres would be permanent filled. Construction at the compressor stations and interconnection sites would require 16 wetland crossings, which would affect 12.4 acres of wetlands. Of these impacts, 9.4 acres would be permanently filled to provide an adequate and safe area to conduct facility operations and to provide room for the addition of necessary infrastructure at the interconnection sites (e.g., condensate tanks, filter separators, and additional pipeline for bi-directional flow). Golden Pass has filed a draft compensatory mitigation plan for the wetland impacts at the MP 33 Compressor Station (see section 4.4.3). Impacts on wetlands from the MP 66 Compressor Station would result in a permanent loss of 0.1 acres. Based on our experience and our review of the alignment sheets, we have determined that impacts on wetlands at the MP 33 and MP 66 Compressor Stations are unjustified. Therefore, **we recommend that:**

- **Prior to the end of the draft EIS comment period, Golden Pass should file with the Secretary revised site plans and associated alignment sheets that avoid permanently impacting all wetlands at the MP 33 and MP 66 Compressor Stations or file documentation that the COE, the TCEQ, the TPWD, and the LDNR have reviewed and agreed with proposed mitigation measures.**

Construction of the Calcasieu Loop would require 27 wetland crossings, resulting in 4.6 acres of impacts (see table 4.4.2-1 and appendix J).

Because 11.4 acres of wetlands would be permanently affected, we conclude that the adverse impacts on wetland resources associated with the Pipeline Expansion would be significant. Compensatory wetland mitigation for the Pipeline Expansion is discussed later in this section.

#### **4.4.2.3 Project-wide Impacts**

Project construction would affect 398.4 acres of wetlands (see table 4.1.1-3). Of these impacts, 396.5 acres would occur in palustrine emergent (PEM) wetlands, while the remaining impacts would affect 1.2, 0.5, and 0.2 acre of palustrine scrub-shrub (PSS), palustrine forested (PFO), and estuarine emergent (EEM) wetlands, respectively.<sup>23</sup> The majority of wetland impacts, 381.9 acres, would involve permanent conversion to industrial-use land in order to provide a safe and stable working surface during facility operations and to allow addition of necessary infrastructure.

Wetlands along the Pipeline Expansion that would be permanently converted to industrial-use land would be crossed using techniques similar to those used for upland crossings (see section 2.6.3). Golden Pass would clear construction work areas of vegetation, grade and fill the areas where necessary to provide a safe working surface, excavate the trench, install the pipe, and backfill the trench. Following construction, the wetlands would be filled with gravel ground cover or other material designed to stabilize the ground surface and prevent erosion. Permanently filled wetlands would no longer support the hydrology, soils, or vegetation necessary to be classified as a wetland and perform the associated wetland functions, such as flood attenuation, water quality improvement, and wildlife habitat.

The remaining 16.5 acres of wetlands that would not be permanently filled (16.2 acres of PEM and about 0.1 acre each of PSS, PFO, and EEM), would be restored to pre-construction contours and allowed to revegetate in accordance with applicable federal and state permits and FERC's Procedures. PEM and PSS wetlands would be restored to pre-construction contours and allowed to revegetate naturally. PFO wetlands that would not be filled would also be restored to pre-construction contours. However, to facilitate periodic pipeline inspections and overflight surveys, PFO wetlands within the 10-foot corridor centered over the pipeline would be permanently maintained in an herbaceous state. Further, Golden Pass would cut and remove trees that are within about 15 feet of the pipeline and greater than about 15 feet in height to ensure that root systems do not interfere with operation of the pipeline.

In PEM wetlands, the impact of construction would be relatively minor and short term, because the herbaceous vegetation would regenerate quickly (generally within 1 to 2 years). The PEM wetland impacts also account for 3.8 acres of agricultural wetlands (PEMf). These wetlands would not be subjected to regular mowing. PSS wetland impacts also would be minor and generally short term, but these wetlands could take 2 to 4 years to reach functionality similar to pre-construction conditions, depending on the age and complexity of the wetland system. While conversion of PFO to PEM wetlands would not constitute a

---

<sup>23</sup> Acreages in this section have been rounded to the tenths of a decimal point for presentation purposes, which accounts for any mathematical discrepancies.

total wetland loss, it does represent a permanent conversion of wetland function. However, it is expected that the converted wetlands would continue to provide important ecological services such as sediment/toxicant retention, nutrient removal and transformation, flood attenuation, and groundwater recharge/discharge.

Wetland crossing procedures are detailed in section 2.6.3.1. Protection measures that would be used during wetland crossings include limiting the use of equipment operating in wetlands, limiting the time that the trench would remain open, keeping vegetation and stump removal to within the trench line only, segregating topsoil from subsoil (unless soils are saturated or inundated), and installing trench breakers on the upland boundary of each wetland. Golden Pass would use equipment mats in wetlands where rutting could occur.

Construction in wetlands could adversely affect wetland hydrology and revegetation by creating soil conditions that may not support wetland communities and hydrophytic vegetation at pre-construction levels. Failure to properly segregate soils during construction could result in mixed soil layers, which could alter the biological components of the wetland and affect re-establishment of native wetland vegetation. Temporary stockpiling of soil and movement of heavy machinery across wetlands could lead to inadvertent compaction and furrowing of soils, which would alter natural hydrologic patterns, inhibit seed germination, and increase seedling mortality. Heavy equipment also could introduce non-native and invasive species to the disturbed soil. Altered surface drainage patterns, stormwater runoff, runoff from the trench, accidental spills, and discharge of hydrostatic test water also could negatively affect wetland regeneration. At HDD crossings of wetlands, no trees would be removed between the entry and exit points along the crossing; however, minor hand clearing of woody vegetation and/or branches may be required along the HDD path. As stated in section 4.3, hydrostatic test water discharge would be directed to upland locations using an energy-dissipation device to minimize erosion. Section 2.0 provides additional details and typical drawings of the Project facilities.

Golden Pass also would adhere to measures in FERC's Procedures during Project construction and operation to minimize or avoid wetland impacts. Table 4.3-4 lists Golden Pass' requested deviations from the FERC Procedures along with the FERC's approval or denial of those requests. Golden Pass also would comply with conditions specified in the COE Section 404 Permit, the TCEQ and the LDNR Section 401 Permits, and the TGLO Section 307 Permit. Specific measures Golden Pass would implement in wetlands include:

- installing sediment barriers across the entire construction workspace immediately upslope of the wetland boundary at all wetlands where necessary to prevent sediment flow into the wetland;
- installing sediment barriers along the edge of the construction right-of-way as necessary to contain spoil within the construction workspace and prevent sediment flow into the wetland;
- dewatering the pipeline trench in a way that does not cause erosion or result in silt-laden water flowing into any wetland;
- constructing trench breakers where a pipeline trench may drain a wetland;
- restoring pre-construction wetland contours;
- installing trench breakers at the base of slopes near the boundary between wetlands and adjacent upland areas;
- limiting routine vegetation mowing to a 10-foot corridor centered over the pipeline trench in wetlands; and

- conducting annual wetland revegetation monitoring of restored wetlands until revegetation is considered successful.

#### 4.4.3 Compensatory Mitigation

The COE requires all unavoidable wetland impacts to be offset by creation, restoration, enhancement, or preservation of at least equal amounts of wetlands, depending on the quality of the wetlands affected and the type of wetlands created, restored, enhanced, or preserved. Direct, long-term effects to wetlands that would occur as part of Project construction, and operation would be subject to compensatory mitigation by one or more of the three mechanisms for providing compensatory mitigation: permittee-responsible compensatory mitigation, mitigation banks, and in-lieu fee mitigation. On July 7, 2014, Golden Pass submitted to the COE a draft *Conceptual Permittee Responsible Mitigation Plan* for wetland losses at the Terminal Expansion and MP 1 Compressor Station in Jefferson County, Texas. Based on input from the COE and other agencies, Golden Pass has subsequently revised its mitigation plans.

On November 10, 2015, Golden Pass submitted a revised draft Compensatory Mitigation Plan, including an updated wetlands functional assessment, for the Terminal Expansion and MP 1 Compressor Station to the Commission (*Draft Compensatory Mitigation Plan for the Golden Pass Products LNG Export Project, Jefferson County, Texas*).<sup>24</sup> Marsh restoration through the use of dredged material was chosen as the preferred method for compensatory mitigation of the wetland losses at these facilities. The proposed marsh restoration site is located 2.5 miles northwest and 3.5 miles west of the Terminal Expansion site within the Salt Bayou Unit of the J. D. Murphree WMA, which is managed by the TPWD. The proposed mitigation project would restore coastal marsh that has been eroded and degraded for more than 100 years by severe weather events and nearby construction activities. The success of this mitigation project, along with restoration projects in adjacent areas and implementation of the 2013 Salt Bayou Watershed Restoration Plan, is expected to improve the overall quality of estuarine wetlands in the Salt Bayou Unit.

On November 10, 2015, Golden Pass also submitted a revised draft Permittee Responsible Mitigation (PRM) Plan and wetlands functional assessment for wetland losses at the MP 33 Compressor Station (*Draft Compensatory Mitigation Plan for the Golden Pass Products LNG Export Project, MP 33 Compressor Station, Orange County, Texas*).<sup>25</sup> Golden Pass would purchase credits at a COE-approved wetland mitigation bank to compensate for wetland losses at these Project facilities. The Pineywoods Mitigation Bank in Angelina, Jasper, and Polk Counties in Texas is the proposed mitigation bank. Orange County is in the secondary service area of this mitigation bank. Additional information on the development; objectives; and proposed work, maintenance, and management methods for both mitigation projects are provided in the PRM Plans.

Golden Pass will update both draft PRM Plans with data collected during ongoing field surveys and continuing agency and land manager correspondence, as applicable. Because the PRM Plans are yet to be finalized for compensatory mitigation commitments, **we recommend that:**

- **Prior to the end of the draft EIS comment period, Golden Pass should file with the Secretary the final *Compensatory Wetland Mitigation Plans* for the Project. These plans should be developed in consultation with the COE, the TCEQ, the TPWD, the LDNR; Golden Pass should file documentation of its consultations with these agencies.**

---

<sup>24</sup> Available at: [http://elibrary.ferc.gov:0/idmws/File\\_List.asp?document\\_id=14397688](http://elibrary.ferc.gov:0/idmws/File_List.asp?document_id=14397688).

<sup>25</sup> Available at: [http://elibrary.ferc.gov:0/idmws/File\\_List.asp?document\\_id=14397688](http://elibrary.ferc.gov:0/idmws/File_List.asp?document_id=14397688).

#### **4.4.4 Conclusion**

Impacts on wetlands associated with the Terminal Expansion and Pipeline Expansion would be significant without mitigation. Based on implementation of the measures discussed above, collocation of the majority of the Project with the existing Golden Pass Pipeline and terminal, and the proposed mitigation measures and our recommendations, impacts on wetlands due to construction and operation of the Project would be reduced to acceptable levels.

### **4.5 VEGETATION**

#### **4.5.1 Vegetation Resources**

The Project would affect 1,017.4 acres of land, of which 553.1 acres are vegetated. Land cover types, such as open water and industrial lands, are discussed in more detail in sections 4.3 and 4.8, respectively. Field surveys of the Project area that were conducted in 2013 and 2014 identified five vegetation cover types: open land (i.e., non-forested uplands, including upland scrub-shrub, maintained utility right-of-way, and pasture), forested uplands, wetlands, silvicultural land, and agricultural land. The majority of the vegetated land that would be affected by the Project is wetlands (394.6 acres), followed by forested uplands (74.6 acres), open lands (51.6 acres), silvicultural lands (22.5 acres) and agricultural lands (9.8 acres).

Wetlands that are being used for rice production or tree farms were considered to be agricultural land. Forested wetland canopies in the general Project area are made of a mixture of bald cypress, Chinese tallow, red ash (*Fraxinus pennsylvanica*), sweetgum, water oak, water tupelo, and willow oak. Common plants identified in non-forested wetland areas include jointed flatsedge, longtom, and yellow nutsedge. Open land in the Project area includes non-forested uplands as well as existing, maintained rights-of-way. Common open land species observed along the pipeline route include bahia grass (*Paspalum notatum*), Bermuda grass (*Cynodon dactylon*), and loblolly pine (*Pinus taeda*). Loblolly pine also is grown in the pine plantations along the Pipeline Expansion route. Pine plantations typically consist of a single species (either slash pine [*Pinus elliottii*] or loblolly pine) and are exclusively used for timber or paper production.

No vegetative communities of special concern were identified in the Project area. Potential habitat for special-status plant species is discussed in section 4.7.

##### **4.5.1.1 Terminal Expansion**

The Terminal Expansion would affect 485.7 acres of vegetated land located within and adjacent to the existing terminal site. Construction of the Terminal Expansion would affect 381.4 acres of wetlands, 63.0 acres of forested upland, and 41.3 acres of open land. Wetlands present in the Project area are discussed in greater detail in section 4.4. No silvicultural or agricultural lands would be affected at the Terminal Expansion site. Table 4.5-1 provides acreages of vegetation cover types that would be affected by construction and operation of the Project.



TABLE 4.5-1 (continued)												
Impacts of the Golden Pass LNG Export Project on Vegetation Cover Types <u>a</u>												
Project Component	Agriculture <u>b</u>		Pine Plantation		Wetlands <u>c</u>		Upland Forest		Open Land		Total	
	Cons <u>d</u>	Oper <u>e</u>	Cons	Oper	Cons	Oper	Cons	Oper	Cons	Oper	Cons	Oper
<b>Calcasieu Parish, LA</b>												
Calcasieu Loop	9.8	4.6	0.9	0.2	0.8	0.5	1.9	0.4	8.9	5.4	22.3	11.0
Calcasieu Loop access road	0.0	0.0	0.0	0.0	0.0 <b>g</b>	0.0	0.0	0.0	0.1	0.0	0.1	0.0
Tennessee Gas Interconnect (MP 63)	0.0	0.0	0.0	0.0	0.3	0.0	0.0	0.0	0.0	0.0	0.3	0.0
MP 63 facility access road	0.0	0.0	0.0	0.0	0.0 <b>g</b>	0.0 <b>g</b>	0.0	0.0	0.0	0.0	0.0 <b>g</b>	0.0 <b>g</b>
MP 66 Compressor Station	0.0	0.0	19.2	14.7	0.1	0.1	0.0	0.0	0.0	0.0	19.3	14.8
TETCO Interconnect (MP 66)	0.0	0.0	0.1	0.1	0.1	0.1	0.0	0.0	0.0 <b>g</b>	0.0 <b>g</b>	0.1	0.1
MP 66 facilities access road	0.0	0.0	1.9	1.9	0.0 <b>g</b>	0.0 <b>g</b>	0.0	0.0	0.0	0.0	1.9	1.9
Transco Interconnect (MP 68)	0.0	0.0	0.3	0.0 <b>g</b>	0.0	0.0	0.0	0.0	0.0 <b>g</b>	0.0	0.4	0.0 <b>g</b>
MP 68 facility access road	0.0	0.0	0.0	0.0	0.0	0.0	0.0	0.0	0.0 <b>g</b>	0.0 <b>g</b>	0.0 <b>g</b>	0.0 <b>g</b>

TABLE 4.5-1 (continued)

Impacts of the Golden Pass LNG Export Project on Vegetation Cover Types a

Project Component	Agriculture <u>b</u>		Pine Plantation		Wetlands <u>c</u>		Upland Forest		Open Land		Total	
	Cons <u>d</u>	Oper <u>e</u>	Cons	Oper	Cons	Oper	Cons	Oper	Cons	Oper	Cons	Oper
<i>Pipeline Expansion Subtotal</i>	9.8	4.6	22.5	16.9	13.2	9.8	11.6	9.6	10.2	6.5	67.3	47.3
<b>TOTAL</b>	<b>9.8</b>	<b>4.6</b>	<b>22.5</b>	<b>16.9</b>	<b>394.6</b>	<b>382.3</b>	<b>74.6</b>	<b>68.3</b>	<b>51.6</b>	<b>47.2</b>	<b>553.1</b>	<b>519.2</b>

Notes:

- a The numbers in this table have been rounded for presentation purposes. As a result, the totals may not reflect the sum of the addends.
- b Agricultural wetlands (i.e., rice fields and PEMf), are reported in the agriculture category.
- c Includes PFO, PSS, PEM, and EEM types.
- d Cons = impacts from construction.
- e Oper = portion of construction impacts that would be permanently maintained following construction.
- f Includes vegetation cover type acreage for the ATWS, the Supply Dock, and the shoreline protection system.
- g Acreage of impacts was greater than zero but less than 0.05 acre and therefore was rounded to 0.0.



Of the 485.7 acres of vegetated land affected at the Terminal Expansion site, 471.9 acres would be permanently filled with gravel or other material (e.g., asphalt) for Project operations. Operation would affect 372.5 acres of wetlands, 58.7 acres of forested uplands, and 40.7 acres of open land. Vegetation would be removed at the ground surface using mechanical or manual methods, or a combination of the two (vegetation would not be burned). Following construction, areas that would not be permanently filled would be restored to their original contours and allowed to revegetate naturally in accordance with the FERC's Plan and Procedures. Additional details of construction procedures are provided in section 2.0. To offset permanent wetland impacts, Golden Pass developed a draft PRM Plan in coordination with the COE (see section 4.4.3). Table 4.3-4 in section 4.3 provides Golden Pass' justifications for the FERC-approved variances, allowing the permanent fill to be placed in these areas. Although impacts on vegetation at the Terminal Expansion would be permanent, the severity of impacts would be decreased when taking into account the disturbed condition of the area; the established presence of the invasive, exotic Chinese tallow; and the compensatory mitigation that would be implemented by Golden Pass.

#### **4.5.1.2 Pipeline Expansion**

Construction of the Pipeline Expansion and aboveground facilities (including all associated access roads and the ATWS) would disturb 67.3 acres of vegetated land. Of the 67.3 acres, 13.2 acres would be wetlands, 11.6 acres would be forested upland, 9.8 acres would be agricultural land, 10.2 acres would be open land, and 22.5 acres would be silvicultural land (see table 4.5-1). About 8.0 acres of the construction footprint would be within or adjacent to the existing Golden Pass Pipeline right-of-way. Operation of the Pipeline Expansion would permanently affect 47.3 acres of vegetated land: 16.9 acres of silvicultural land, 9.8 acres of wetlands, 9.6 acres of forested upland, 6.5 acres of open land, and 4.6 acres of agricultural land. About 5.5 acres of the operational footprint would be within the existing right-of-way.

Construction of the Calcasieu Loop (including the associated access road and the ATWS) would affect 22.5 acres of vegetated land. Golden Pass would reduce impacts on wetland vegetation by using an HDD for approximately 1.0 mile. Construction of the Calcasieu Loop would affect 9.8 acres of agricultural land, 9.0 acres of open land, 1.9 acres of forested upland, 0.9 acre of silvicultural land, and 0.8 acres of wetlands. Of the 22.5 acres, 11.0 acres of vegetated land would be permanently disturbed by Project operations, including 5.4 acres of impacts on open land, 2.0 acres of PEM wetlands, less than 0.1 acre of PFO wetlands, 0.4 acre of forested upland, and 0.2 acre of silvicultural land. All permanent impacts would occur along the existing pipeline right-of-way and the ATWS would be restored to their pre-construction condition. Impacts on vegetation associated with installation of the pipeline primarily would be caused by vegetation clearing within the construction right-of-way and associated ATWS. With the exception of areas that would be crossed by HDD, vegetation would be cleared from the entire working right-of-way. Vegetation removal between the entry and exit pits of HDD crossings would be limited to the minor hand clearing of woody vegetation and/or branches along the HDD path, as needed. The construction right-of-way width in open-cut wetlands would be reduced to 75 feet, where practicable. Vegetation would be removed at the ground surface using mechanical or manual methods. Following vegetation removal, the construction right-of-way would be graded to allow for safe, level working conditions. Removal of tree stumps and root systems and surface grading would be limited to the area directly over the trenchline, unless approved by the appropriate Project inspectors, including an EI. Once the pipeline is installed, the trench would be backfilled, and the temporary right-of-way would be allowed to revegetate naturally as part of the Project's restoration process. In wetlands crossed by the pipeline right-of-way, with the exception of those crossed by HDD, a 10-foot-wide corridor centered over the trenchline would be regularly mowed and maintained in an herbaceous state to facilitate periodic pipeline corrosion/leak surveys. Golden Pass also would remove trees that are taller than 15 feet and located within 15 feet of the pipeline centerline to ensure that root systems do not interfere with operation of the pipeline.

The duration and magnitude of impacts on vegetation would depend on the type and amount of vegetation affected, the rate at which vegetation regenerates after construction, and the frequency of vegetation maintenance conducted on the right-of-way during pipeline operation. In addition, right-of-way revegetation would depend on factors such as soil types, right-of-way maintenance practices, and land use. The Pipeline Expansion would cause minor and generally short-term changes on agricultural, scrub-shrub, herbaceous wetlands, and upland areas because these areas would revegetate within 1 to 4 years. Impacts on forested areas that are not located in areas of regular mowing would be long term, because re-establishment of forested vegetation may require from 10 to 30 years, depending on the species.

The permanent right-of-way generally would be 50-feet-wide. Portions of the Project would be collocated with the existing Golden Pass Pipeline right-of-way to minimize impacts on vegetation. In these areas of collocation, 25 feet of the 50-foot-wide permanent right-of-way would overlap the existing Golden Pass Pipeline right-of-way. Additionally, Golden Pass would HDD a portion of the pipeline, reducing impacts on vegetation. Therefore, impacts on vegetation would be minimized to the extent practicable.

### **Compressor Stations and Interconnections**

Construction of the compressor stations and interconnections (including access roads and the ATWS) would affect 44.9 acres of vegetated land. Table 4.5-1 provides the acreage of impacts for each compressor station and interconnection. Of the 44.9 affected acres, 1.2 acre is open land, 21.6 acres are silvicultural land, 12.4 acres are wetlands, and 9.7 acres are forested upland. Of the 44.9 affected acres, 36.3 acres of vegetated land would be permanently disturbed by Project operations. Operational impacts would include 1.1 acre of open land, 9.4 acres of wetlands, 16.7 acres of silvicultural land, and 9.2 acres of forested upland. Project construction would require vegetation clearing and grubbing within the construction workspace, surface grading, and placement of permanent fill for facility operations. Affected areas that would not be permanently filled would be allowed to revegetate naturally.

### **Pipe Storage and Contractor Yard**

Golden Pass would site their pipe storage and contractor yard on 13.0 acres of graveled, industrial-use land, and existing roads would be used to access the site. Golden Pass would grade and re-gravel the access roads, as necessary; the need for additional modifications is not anticipated. Following construction, Golden Pass would restore the site to pre-construction conditions in adherence to FERC's Plan. No Project-related impacts on vegetation would occur at this site.

### **Additional Temporary Workspaces**

The ATWS areas would affect 7.2 acres during construction, including 0.5 acre of upland forest, 1.1 acre of PEM wetlands, and 5.6 acres of pine plantation. Impacts associated with herbaceous wetlands generally would be short term, while impacts on forested vegetation would be long term.

Golden Pass proposes to use the HDD method to cross about 1 mile of the route dominated by PEM wetlands along the Calcasieu Loop. No major vegetation clearing would occur between the entry and exit points of the HDD; however, minor hand clearing of woody vegetation and/or branches would be required during construction along the HDD guide wire.

#### **4.5.1.3 Conclusion**

To minimize direct and indirect impacts on vegetative cover types in the Project area, Golden Pass would follow the requirements of FERC's Plan. These requirements include:

- marking the limits of construction area and access roads prior to clearing

- installation of temporary and permanent erosion control measures, such as sediment barriers, and mulch;
- segregating topsoil, where applicable;
- ensuring topsoil is replaced and contours are restored during restoration;
- reseeding disturbed areas, where applicable;
- commencement of cleanup immediately after backfilling and completion of restoration; and
- monitoring revegetation efforts until restoration is successful.

Given implementation of the measures discussed above and collocation of the majority of the right-of-way to overlap with existing rights-of-way, we believe that impacts on vegetation would be minimized. Therefore, construction and operation of the Project would not significantly affect vegetation.

#### **4.5.2 Exotic or Invasive Plant Communities and Noxious Weeds**

Exotic plant communities, invasive species, and noxious weeds can out-compete and displace native plant species, thereby negatively altering the appearance, composition, and habitat value of affected areas. Chinese tallow is the only noxious weed of concern present in portions of the Project area (USDA, 2015).

Chinese tallow trees establish easily, grow quickly, and produce large quantities of seeds that are long-lived and spread by water, birds, and mammals. Golden Pass proposes to control the spread of Chinese tallow trees by managing their growth and distribution, using the methods recommended by the NRCS. These include spraying the trees with herbicide, targeting the leaves or the stems, to prevent growth and reproduction. Prior to construction, Golden Pass would consult with the NRCS to determine acceptable application rates and spray times suitable for control of tallow trees along the pipeline route. Golden Pass would develop specific procedures in coordination with NRCS to prevent the introduction or spread of noxious weeds and soil pests resulting from construction and restoration activities. Golden Pass' EIs would verify that the soils imported for agricultural use have been certified as free of noxious weeds and soil pests. Pre-construction surveys, specifically for noxious weeds, are not proposed; however, Golden Pass would provide pre-construction training to construction crews for identification and reporting of noxious weeds to EIs. Based on the proposed control measures, the spread of noxious and invasive weeds would be minimized to the extent practicable.

### **4.6 WILDLIFE AND AQUATIC RESOURCES**

#### **4.6.1 General Wildlife Resources**

Wildlife species in the Project area are characteristic of the communities that inhabit the vegetative habitats that occur in the vicinity of the Project as identified through literature review, interpretation of aerial photography, and Golden Pass' field reconnaissance.

##### **4.6.1.1 Terminal Expansion**

###### **Existing Wildlife Habitat**

The wildlife habitat types at the Terminal Expansion site include wetlands, tidal marsh, open water, upland forest, and open upland habitat (BES, 2013a).

Wetlands and tidal marshes provide habitat for waterfowl, wading birds, raptors, mammals, reptiles, and amphibians. Typical wildlife associated with these habitats include: wood duck; pileated

woodpecker; snowy, great, and cattle egrets; green, little blue, and great blue herons; king rail; marsh hawk; red-winged blackbird; common muskrat; swamp rabbit; beaver; nutria; eastern cottonmouth and diamond-backed water snakes; bronze frog; and eastern Missouri slider (Cornell University, 2011a; Herps of Texas 2014a; LDWF, 2014; TPWD, 2005, 2014a). Wetlands are discussed further in section 4.4.

Open water habitat within the Terminal Expansion site occurs along the SNWW. Similar to wetland habitat, open water habitat provides food and water sources, in addition to habitat, for wildlife species such as wading birds, waterfowl, beavers, nutria, snakes, turtles, and other wildlife species dependent on an aquatic environment (Cornell University, 2011a; Herps of Texas, 2014a; LDWF, 2014; TPWD, 2005, 2014a). Waterbodies are discussed further in section 4.3.2.

Upland forest and scrub-shrub on the Terminal Expansion site occurs along the SNWW shoreline in areas of abandoned dredged material that has altered the natural wetland habitat characteristics. Upland forest habitat is part of the Piney Woods region. It is characterized by longleaf and slash pine forests that provide habitat for a diverse assemblage of bird species, including barred and great horned owl, Cooper's hawk, wild turkey, and various woodpeckers and songbirds such as the red-cockaded woodpecker and yellow warbler. Mammal species include gray squirrel, opossum, raccoon, white-tailed deer, red fox, and various rodents. Reptiles and amphibians include corn snake, green anole, marbled salamander, northern cricket frog, central newt, and timber/canebrake rattlesnake (Cornell University, 2011a; Herps of Texas, 2014a; LDWF, 2014; TPWD, 2005, 2014a). Open upland habitat is predominantly composed of vegetation less than 5 meters in height. It provides forage and nesting habitat for species such as the field sparrow, northern cardinal, coyote, cottontail rabbit, armadillo, red fox, hognose snake, and Texas ratsnake (Cornell University, 2011a; Herps of Texas, 2014a; LDWF, 2014; TPWD, 2005, 2014a).

### **Wildlife Resources Impacts and Mitigation**

Construction and operation of the Terminal Expansion would result in permanent alteration of wetland, open water, upland forest, and scrub-shrub habitats. A total of 669.5 acres of wildlife habitat would be affected by construction of the Terminal Expansion facilities. Affected habitat includes 381.4 acres of wetlands; 183.7 acres of open water, including SNWW intertidal waters; 63.0 acres of upland forest; and 41.3 acres of open uplands. Operation of the Terminal Expansion would result in a permanent conversion of 372.5 acres of wetlands, 58.7 acres of upland forest, and 40.7 acres of open upland to industrial land. In addition, 70.5 acres of open water would be within the operational footprint of the Project, including 65.8 acres for the Supply Dock and existing Ship Slip, 2.9 acres filled for building and infrastructure, 0.6 acre for workspace, and 1.3 acres for shoreline protection. Land uses at the Terminal Expansion site are discussed in section 4.8 and listed in table 4.8.1-1.

Terminal Expansion construction would require vegetation clearing, grading, and filling to level the site. This would reduce cover, nesting, and foraging habitat for some species and may result in mortality of less mobile forms of wildlife, such as small rodents and reptiles. Other wildlife, such as birds and larger mammals, would be expected to leave the area as construction activities approach. These animals may relocate into similar habitats nearby such as the J. D. Murphree WMA. If a lack of adequate territorial space were to exist adjacent to the site, these animals could be forced into suboptimal habitat and/or increased densities, which could lower reproductive success and survival.

Construction of the Terminal Expansion would convert 471.9 acres of existing habitat vegetation to industrial land. Although the Terminal Expansion site is adjacent to previously disturbed land and in proximity to routine dredging activity, wildlife habitat would be affected within the Terminal Expansion site. However, a large amount of similar or higher quality habitat exists adjacent to and near the Terminal Expansion site. In addition, because of previous development and current industrial activities within and around the Terminal Expansion area, it is expected that most wildlife species in the area are acclimated to

these activities. Thus, impacts associated with noise, light, and human activity would be expected to be minor.

Pilings would be installed during the Terminal Expansion using hammer or vibratory methods. Noise resultant from pile driving activities has the potential to alter wildlife behavior, including foraging and nesting activities within the Project area. Pile driving noise would be intermittent and temporary, and preparatory activities likely would encourage mobile species to leave the immediate area prior to commencing pile driving. Less mobile species would be subject to resulting noise. During construction, Golden Pass would implement noise mitigation measures to reduce potential impacts on the human environment and wildlife from pile driving activities. Noise mitigation measures are described in section 4.11.2 and include:

- use of a cushioning system to reduce noise and maintain effectiveness of pile driving; and
- limiting pile driving activities to 1 hour before sunrise to 1 hour after sunset, except in limited situations where additional time is needed to safely secure a piling.

Throughout construction and operation of the Terminal Expansion, Golden Pass would follow FERC's Plan and Procedures and would implement protective measures for migratory and colonial nesting bird species, as discussed in section 4.6.1.3. With adherence to the proposed mitigation measures and given the abundance of suitable habitat in adjacent areas, the impacts on wildlife habitats from construction and operation of the Terminal Expansion would be adequately minimized.

#### **4.6.1.2 Pipeline Expansion**

##### **Existing Wildlife Habitat**

Wildlife habitat within and around the Pipeline Expansion includes wetlands, upland forest, open grasslands (including maintained right-of-way), agricultural land, landscaping on developed land (industrial and residential), and managed silvicultural lands (BES, 2013b). Fisheries habitats are discussed in section 4.6.2.

Wetland (PEM, PSS, and PFO) and upland forest habitats provide foraging and nesting habitat for a variety of waterfowl, raptors, songbirds, mammals, reptiles, and amphibians, as described in section 4.6.1.1. A majority of the upland forest habitat along the Pipeline Expansion consists of managed silvicultural lands, primarily planted pine, that support a variety of upland forest species. Open grassland habitats primarily include herbaceous communities with limited canopy cover; they provide foraging and breeding habitat. Avian and mammalian species that use grassland habitat include the American goldfinch, red-tailed hawk, deer mouse, eastern mole, and cotton rat. Amphibians and reptiles found in forest habitat include the black rat snake, eastern garter snake, and southern toads (Cornell University, 2011a; Herps of Texas, 2014a; LDWF, 2014; TPWD, 2005, 2014a).

Agricultural lands are frequently disturbed; they provide habitat for edge-dwelling species that can tolerate or thrive on disturbance. Edge habitats are transition zones where two ecosystems come together, such as forested and non-forested cover types. Certain species prefer these transition zones, as they provide certain types of food and cover in one area. Typical wildlife species that use agricultural lands are doves, ducks, geese, and songbirds; white-tailed deer; eastern cottontail rabbit; and small rodents (Cornell University, 2011a; Herps of Texas, 2014a; LDWF, 2014; TPWD, 2005, 2014a).

##### **Wildlife Resources Impacts and Mitigation**

Construction of the Pipeline Expansion would temporarily disturb 67.4 acres of wildlife habitat during construction, of which 47.3 acres would be permanently altered during operation for maintenance

of the pipeline right-of-way and aboveground facilities, including the new pipeline, compressor stations, interconnections, and access roads (see table 4.5.1-1). A total of 16.9 and 9.6 acres of silviculture forest and upland forest, respectively, would be permanently affected by the Pipeline Expansion. In addition, 9.4 acres of PEM wetlands would be permanently converted to developed land for aboveground facilities.

The impact of construction on wildlife species and their habitats would vary depending on the resource requirements of each species and the existing habitat present along the pipeline route and at aboveground facilities. The greatest effects to wildlife would occur during cutting, clearing, and/or removal of existing vegetation, which would reduce the amount of available habitat within the construction right-of-way and temporary workspaces. The degree of temporary impact would depend on the rate at which vegetation regenerates after construction. Herbaceous and scrub-shrub habitats generally revegetate within 4 years of disturbance, while forested areas may take 30 years or more to completely recover.

Clearing of the temporary construction right-of-way would reduce cover, nesting, and foraging habitat for some species and may result in direct mortality for less mobile forms of wildlife, such as small rodents and reptiles. Larger or more mobile wildlife, such as birds and large mammals, would be expected to leave the right-of-way as construction begins and relocate into similar habitats in the vicinity of the Pipeline Expansion facilities. However, if a lack of adequate territorial space exists, some individuals could be forced into suboptimal habitats. This could increase inter- and intra-specific competition and lower reproductive success and survival. The potential influx and increased density of species in some undisturbed areas could reduce the reproductive success of animals that are not displaced by construction. These effects would cease after completion of construction and right-of-way restoration, when wildlife could return to the disturbed areas and adjacent undisturbed habitats after restoration is complete. Species that use early successional shrub or forest communities may benefit from the clearing and revegetation process, as additional habitat of this type would be created by construction of the Pipeline Expansion. In addition, non-woody, early successional vegetation may provide forage for small mammals and birds, as well as breeding habitat for ground-nesting birds, mammals, and reptiles.

In forested areas, construction of the Pipeline Expansion would relocate the edge habitat, as the entire route is adjacent to or near existing cleared rights-of-way. These habitats are used by various wildlife species, such as songbirds and small mammals. Many species can adapt to this habitat shift and could take advantage of the edge habitats. Predatory species such as red-tailed hawk and coyote commonly use utility rights-of-way for hunting; other species, such as the eastern cottontail, mourning dove, field and song sparrow, white-tailed deer, and red fox, could benefit from the transition to early successional habitat for foraging (TPWD, 1999, 2005).

Although impacts may be advantageous for some species, construction and operation of the Pipeline Expansion would widen existing cleared rights-of-way; species that use tree cavities for roosting or nesting may suffer direct mortality during right-of-way clearing. Species that prefer large tracts of unbroken forest would be indirectly affected by clearing of forest habitat. In addition, nesting success may be denied or diminished for one annual breeding cycle for adult birds that normally would breed in the area but would avoid it during construction activities. The slow regeneration of forested communities within the temporary right-of-way would result in a long-term reduction in forested habitat for species that use these communities; however, abundant similar habitats are available for wildlife adjacent to the Pipeline Expansion facilities. To further reduce impacts on nesting birds during pipeline operation, routine vegetation mowing or clearing would not occur along the entire width of the permanent right-of-way more frequently than every 3 years—except for a corridor not exceeding 10 feet in width centered on the pipeline that would be cleared at a frequency necessary to maintain an herbaceous state—and routine vegetation mowing or clearing would not occur during the migratory bird nesting season between April 15 and August 1.

Agricultural lands are areas that are regularly disturbed; they would be available for replanting during the next growing season following installation of the pipeline. Therefore, we believe that impacts on wildlife that use agricultural lands would be short term and insignificant.

Golden Pass would collocate the pipeline facilities to overlap with existing rights-of-way and facilities as much as practical. Golden Pass would adhere to FERC's Plan and Procedures and other measures discussed in this EIS. Furthermore, because the entire pipeline would be collocated with the existing Golden Pass Pipeline, we do not expect that widening of the right-of-way would significantly affect wildlife populations. Therefore, impacts on local wildlife populations during construction and operation of the Pipeline Expansion would not be significant.

#### **4.6.2 Unique and Sensitive Wildlife Species**

Unique or sensitive wildlife species, such as migratory birds and colonial nesting waterbirds, may be present in the vicinity of the Project. Species federally and state-listed as threatened and endangered, and other species of concern are discussed in section 4.7.

##### **4.6.2.1 Migratory Birds**

Migratory birds are protected under the Migratory Bird Treaty Act (MBTA) and Executive Order (EO) 13186. Bald and golden eagles also are protected under the Bald and Golden Eagle Protection Act. Bald eagles are further discussed in sections 4.6.2.4 and 4.7.2. The Executive Order was enacted, in part, to ensure that environmental analyses of federal actions evaluate the impacts of actions and agency plans on migratory birds. The Executive Order also states that emphasis should be placed on species of concern, priority habitats, and key risk factors; and it prohibits the take of any migratory bird without authorization from the FWS. Destruction or disturbance of a migratory bird nest that results in the loss of eggs or young also is a violation of the MBTA. Numerous migratory bird species, including colonial nesting waterbirds, waterfowl, and neotropical songbirds, have the potential to occur in the Project area.

On March 30, 2011, the FWS and the Commission entered into a MBTA Memorandum of Understanding that focuses on avoiding or minimizing adverse impacts on migratory birds and strengthening migratory bird conservation through enhanced collaboration between the two agencies. This voluntary MBTA Memorandum of Understanding does not waive legal requirements under the MBTA, Bald and Golden Eagle Protection Act, ESA, Federal Power Act, NGA, or any other statutes, and does not authorize the take of migratory birds.

Migratory birds follow broad routes called "flyways" between breeding grounds in Canada and the United States and wintering grounds in Central and South America, and the Caribbean. In addition, several species migrate from breeding areas in the north to winter along the Gulf Coast and remain throughout the non-breeding season. The Project is in the Central Flyway and at the western edge of the Mississippi Flyway (Audubon, 2014a, 2014b). In addition, birds traveling the Atlantic Flyway may turn westward to the Texas Gulf Coast (Audubon, 2014c). The Gulf Coast provides wintering and migration habitat for significant numbers of continental duck and geese populations that use both the Central and Mississippi Flyways.

The Terminal Expansion site, while adjacent to previously disturbed land and in proximity to dredging activity, does contain suitable breeding and foraging habitat for migratory birds. The migratory birds that use the wetland and open water habitats at the Terminal Expansion site include various species of waterfowl and water birds. Species in this type of habitat are predominantly American coot; red-winged blackbird; white ibis; and various species of ducks, rails, egrets, and herons (Audubon, 2014a, 2014b; Cornell University, 2011a; TPWD, 2005, 2014a). Although wetland habitats in the Terminal Expansion area provide habitat for migratory waterfowl and waterbirds, no nests or rookeries were documented during

2013 field surveys (BES, 2013c). Construction and operational impacts on migratory birds and their habitat within the Terminal Expansion site would be similar to the impacts on general wildlife resources discussed in section 4.6.1.1.

A variety of migratory bird species, including songbirds and raptors, use the vegetation communities in the vicinity of the Pipeline Expansion route; however, no nests or rookeries were documented during field 2013 surveys (BES, 2013d). Construction and operational impacts of the Pipeline Expansion on migratory birds and their habitat would be similar to impacts on general wildlife resources. To further minimize potential impacts on nesting birds during operation, Golden Pass would conduct routine vegetation mowing or clearing no more frequently than every 3 years, except for a corridor not exceeding 10 feet in width centered on the pipeline that would be cleared at a frequency necessary to maintain an herbaceous state. Golden Pass would not conduct routine vegetation mowing or clearing during the migratory bird nesting season between April 15 and August 1.

To avoid and minimize potential impacts on migratory birds, Golden Pass would implement the following measures that were developed in consultation with the FWS, the TPWD, and the Louisiana Department of Wildlife and Fisheries (LDWF) (LDWF, 2013b; TPWD, 2013b; FWS, 2013a, 2013b, 2013c, 2014a):

- collocate Project facilities with existing infrastructure;
- conduct pre-construction surveys during the nesting season to identify unavoidable migratory bird habitat, such as rookeries and/or nesting colonies;
- follow reseeded recommendations from the NRCS for restoration of temporarily disturbed areas;
- minimize security and night-time lighting to the extent practicable and adhering to the FWS guidelines on lighting type and color; and
- adhere to the measures in FERC's Plan and Procedures, as well as the Golden Pass SPCC Plan and Stormwater Pollution Prevention Plan (SWPPP) to minimize impacts on sensitive habitats.

In addition, Golden Pass would adhere to the monitoring procedures identified in the *Bird Strike Monitoring Plan* (see appendix K). The *Bird Strike Monitoring Plan* identifies two seasons wherein weekly monitoring for dead or injured birds would occur at 18 stations. The plan provides procedures for monitoring, documentation, carcass disposal, and injured bird transportation. The monitoring data will be reported to the FERC and the FWS. We reviewed this plan and find it acceptable.

Lighting of the aboveground structures at the Terminal Expansion would be required in order to meet applicable federal safety and security standards; lighting could result in increased migratory bird strikes due to confusion or disruption of migration habits. To minimize potential impacts from facility lighting, Golden Pass would minimize security and nighttime lighting to the extent practicable, shade and downward project lighting where possible, and adhere to the FWS guidelines on lighting type and color. This would include using only white or red strobe lights at night, using the fewest number of lights as practicable, and using the minimum intensity and number of flashes per minute allowable. Solid red or pulsating red warning lights would be avoided when possible.

Golden Pass would continue to consult with the FWS, the TPWD, and the LDWF regarding potential impacts on migratory birds in the Project area and would implement any additional measures determined through agency coordination.



Based on field survey results, the abundance of available habitat in the vicinity of the Project, and Golden Pass' commitment to implementing the above avoidance, minimization, and mitigation measures, adverse impacts on migratory birds would be minimized to the extent practicable.

#### **4.6.2.2 Birds of Conservation Concern**

In response to a 1998 amendment to the Fish and Wildlife Conservation Act, the FWS established a list of Birds of Conservation Concern (BCC) that, without conservation action, were expected to become candidate species for listing under the ESA (FWS, 2008). The BCC list includes species of concern at national, FWS region, and Bird Conservation Region (BCR) geographic scales. The Terminal Expansion is located within BCR 37, also known as the Gulf Coastal Prairie habitat. In 2008, the FWS Migratory Bird Management Program provided a complete list of breeding and non-breeding birds present in this region. There are 44 BCC species included on the FWS' BCR 37 list, of which 23 are breeding species and 21 are non-breeding species (FWS, 2008).

Potential impacts on BCC from Project construction and operation are similar to those described for migratory birds. Based on the abundance of available habitat in the vicinity of the Project and Golden Pass' commitment to implementing avoidance, minimization, and mitigation measures; adverse impacts on BCC would be minimized.

#### **4.6.2.3 Colonial Nesting Waterbirds**

Colonial nesting waterbirds are those that forage predominately in aquatic environments and gather in rookeries of numerous individuals during nesting season. Colonial nesting waterbirds that occur in the Project area include various herons, egrets, ibises, terns, gulls, pelicans, and other species. To minimize disturbance to nesting waterbirds, the FWS restricts construction activity within 1,000 feet of rookeries to the non-nesting season (September 1 to February 15 in Texas, and August 1 to February 15 in Louisiana) (FWS, 2013a, 2013b). No rookeries were identified within 1,000 feet of the Project area during field surveys, and no rookeries are known to occur within 2.5 miles of the Project area (BES, 2013c, 2013d).

Based on the FWS guidance, Golden Pass would educate onsite personnel to be cognizant of colonial nesting waterbirds, conduct pre-construction surveys, and restrict construction activities within 1,000 feet of any identified rookeries (FWS 2013a, 2013b). Based on the lack of known occurrences of rookeries in the Project area, Golden Pass' adherence to the FWS restrictions, and completion of pre-construction surveys, impacts on colonial nesting waterbirds caused by construction and operation of the Project would be minimized to extent practicable.

#### **4.6.2.4 Bald Eagle**

The bald eagle was federally listed as endangered in 1967 primarily because the use of dichlorodiphenyltrichloroethane (DDT) caused thinning of eggshells and a decrease in survivorship of the eggs (EPA, 2014a). A recovery plan was put in place and the use of DDT was curtailed, which allowed the bald eagle population to increase significantly. It was subsequently delisted as a federally endangered species in 2007 but is still federally protected by the Bald and Golden Eagle Protection Act, which prohibits "taking" of bald eagles, including their parts, nests, or eggs (EPA, 2014a; FWS, 2014c). Taking also includes disturbance, which means bothering or agitating a bald eagle to the point of injury, decrease in productivity, or nest abandonment (FWS, 2014c). The eagle winters and breeds throughout the United States along river systems, next to large lakes, and along coastal areas. In Texas and Louisiana, bald eagles winter along the coast and near some lakes in the northern part of the states; they nest in winter and early spring. Bald eagles tend to use the same nest year after year and, in the southern United States, nests are usually constructed in large cypress trees (EPA, 2014a). Bald eagles generally feed on fish, but their diet

also includes waterfowl, carrion, muskrats, and nutria. Current threats to this species include loss of nesting habitat and disturbance to nesting pairs from humans during the nesting season (EPA, 2014a; FWS, 2014c).

The bald eagle could winter or breed in areas near the Terminal Expansion site and Pipeline Expansion route, and potential foraging and nesting habitat exists near the Terminal Expansion site and Pipeline Expansion route. However, Golden Pass conducted surveys in July, August, and November 2013, and no nests were found within 0.5 mile of the Terminal Expansion site or the Pipeline Expansion route. No bald eagle nesting sites are known to occur within 2.5 miles of the Project (LDWF, 2013; TPWD, 2013c). Based on FWS' recommendation (FWS, 2013b), if a bald eagle nest is identified within 660 feet of Project activities, Golden Pass would complete an online evaluation to determine whether the Project is likely to disturb nesting bald eagles and whether additional consultation is necessary. In addition, Golden Pass would implement recommendations in the National Bald Eagle Management Guidelines (FWS, 2007), including:

- maintaining a specified distance between the nest and project activities;
- maintaining natural areas between the nest and project activities; and
- avoiding specific activities during the breeding season.

Based on the lack of known occurrences of nesting sites, the species' mobility and Golden Pass' adherence to the National Bald Eagle Management Guidelines, impacts on the bald eagle during construction and operation of the Project would be minor.

#### **4.6.2.5 Managed and Sensitive Wildlife Areas**

No national wildlife refuges or state wildlife management areas are within the Project area. The J. D. Murphree WMA is about 0.25 mile away and across a state highway from the MP 1 Compressor Station and the Terminal Expansion site. No construction would occur on the WMA side of the highway; therefore, any impacts on the refuge would be minor and limited to temporary increases in construction-related traffic, noise, and lighting. Section 4.8.4 provides further information on this refuge.

#### **4.6.3 Aquatic Resources**

Aquatic habitat associated with waterbodies that would be affected by the Project include estuarine habitat of the SNWW adjacent to the Terminal Expansion and three man-made ditches along the Pipeline Expansion.

##### **4.6.3.1 Terminal Expansion**

###### **Existing Aquatic Resources**

Typical recreational fish species that may exist in the SNWW at the Terminal Expansion site are listed in table 4.6.3-1. No commercial finfish harvest occurs in the SNWW; however, commercial shrimping and crabbing do occur, especially north of the Terminal Expansion area. Impacts on sensitive fisheries, such as penaeid shrimp and red drum, and EFH are described in section 4.6.3.

**TABLE 4.6.3-1**

**Fish Species Occurring in Waterbodies Affected by the Golden Pass LNG Export Project a**

<b>Common Name</b>	<b>Scientific Name</b>	<b>Project Occurrence</b>	<b>Classification</b>
Crawfish	<i>Cambarus</i>	Pipeline	Freshwater
Sailfin molly	<i>Poecilia latipinna</i>	Pipeline	Freshwater
Mosquitofish	<i>Gambusia affinis</i>	Pipeline	Freshwater
Atlantic croaker	<i>Micropogonias undulates</i>	Terminal	Estuarine/Recreational
Gulf menhaden	<i>Brevoortia patronus</i>	Terminal	Estuarine/Recreational
Hardhead catfish	<i>Ariopsis felis</i>	Terminal	Estuarine/Recreational
Red drum	<i>Sciaenops ocellatus</i>	Terminal	Estuarine/Recreational
Sheepshead	<i>Archosargus probatocephalus</i>	Terminal	Estuarine/Recreational
Southern flounder	<i>Paralichthys lethostigma</i>	Terminal	Estuarine/Recreational
Spot	<i>Leiostomus xanthurus</i>	Terminal	Estuarine/Recreational
Spotted seatrout	<i>Cynoscion nebulosus</i>	Terminal	Estuarine/Recreational
Striped mullet	<i>Mugil cephalus</i>	Terminal	Estuarine/Recreational
Spanish mackerel	<i>Scomberomorus maculatus</i>	Terminal	Estuarine/Recreational
Blue crab	<i>Callinectes sapidus</i>	Terminal	Estuarine/Recreational/ Commercial
Brown shrimp	<i>Farfantepenaeus aztecus</i>	Terminal	Estuarine/Recreational/ Commercial
White shrimp	<i>Litopenaeus setiferus</i>	Terminal	Estuarine/Recreational/ Commercial
Eastern oyster	<i>Crassostrea virginica</i>	Terminal	Estuarine/Recreational
<u>Note:</u>			
<b>a</b> All waterbodies and fisheries are classified as warmwater.			

The aquatic habitat in the SNWW near the Supply Dock consists mainly of relatively deep (over 40 feet) open water habitat separated from the shoreline by subtidal and intertidal shallow, unvegetated sand and mud flats. Subtidal soft sediments provide feeding habitat for demersal fish and benthic infauna. Unconsolidated subtidal habitat has been designated as EFH for penaeid shrimp; this EFH is described in section 4.6.3. All unconsolidated sediments in the SNWW, including subtidal and intertidal areas, are considered early successional because of the constant disturbance from maintenance dredging, propeller wash, vessel traffic, and natural sedimentation.

**Aquatic Resources Impacts and Mitigation**

Potential impacts on aquatic resources related to the Terminal Expansion would be associated with construction and operation of the Supply Dock, modifications at the existing Golden Pass Import Terminal Ship Slip, hydrostatic testing, vessel operations, alterations to stormwater drainage, and the potential for an inadvertent release of petroleum or LNG.

## Supply Dock

To construct the Supply Dock Golden Pass would dredge within a 13.2-acre area of the SNWW. Golden Pass proposes to use mechanical excavation for 22,000 yd<sup>3</sup> of upland material and hydraulic cutterhead dredging for the remaining 283,750 yd<sup>3</sup> during construction of the Supply Dock. The construction activities related to these facilities could result in siltation at the water's edge and temporarily increase turbidity and suspension of solids within the water column. Increases in turbidity can affect fish physiology and behavior. Potential physiological effects include mechanical abrasion of surface membranes, delayed larval and embryonic development, reduced bivalve pumping rates, and interference with respiratory functions. Foraging fish may experience possible behavioral effects from increased turbidity, including interference with feeding from visual impairment and area avoidance. Alternately, the reduced visibility of predatory fish could lower vulnerability to predation by these species. Turbidity also interferes with light penetration and thus reduces photosynthetic activity by phytoplankton. Such reductions in primary production would be localized to the immediate work area and limited to the duration of the sedimentation plume. Excessive nutrient loading from sediment resuspension also could cause an adverse impact because of potential increases in the productivity of planktonic algal populations. Because the SNWW has a naturally high suspended sediment load associated with vessel activity and maintenance dredging, the temporary increase in suspended sediments typically created by a hydraulic dredge would not be significant. In addition, Golden Pass would comply with all requirements of its CWA Section 404 permit and implement BMPs in its SPCC Plan to mitigate increases in turbidity and erosion. Therefore, water quality impacts on aquatic species due to dredging would be temporary and localized.

Dredging activities also would affect the shallow estuarine bottom habitat, in addition to the water column. Benthic organisms, such as mollusks and crustaceans, may experience direct mortality during these activities; while other more mobile species, such as blue crab and demersal finfish, may experience temporary displacement. The construction-related impacts would be greatest on the benthic community within the dredging area; impacts on saltwater fish species, such as red drum and spotted seatrout, also could occur but would be localized and temporary. Because of the short duration of dredging, these species and other similar species would be temporarily displaced and could return upon completion of construction of the Supply Dock. Although the benthic community would be directly affected, these communities generally re-populate within 1 year (MMS, 2004); therefore, impacts on the benthic community from dredging for construction of the Supply Dock would be short term and minor. The barge slip at the Supply Dock would be maintained at a depth of 20 feet at mean lower low water. Maintenance dredging of the Supply Dock would require a permit from the COE and dredging would continue periodically during the life of the Project, resulting in localized, short-term impacts on water quality and the benthic community when dredging did occur.

During construction, sheet pilings and dock pilings near the bank of the SNWW would be vibrated until refusal and then driven with a hammer pile driver to the final depth of 100 to 150 feet, dependent on load. Most pile driving would occur on land prior to excavation or dredging. Installation of pilings on land would reduce noise impacts because the ground would dissipate the sound generated from pile driving; however, the occurrence of these activities near the water could generate underwater sound pressure waves that can adversely affect nearby marine organisms. In addition, approximately 10 piles would be driven from a barge. Depending on the sound frequency and intensity, this activity could cause a change in aquatic species behavior, including avoidance of the area. Based on Golden Pass' proposed construction methods, the behavior of aquatic species may be affected, but these species are likely to avoid the area temporarily and return once construction activities have ceased. Therefore, impacts on aquatic species from pile driving activities would be temporary, localized, and minor.

During construction of the Supply Dock, additional lighting and noise would be present at the construction site. However, aquatic species in the area are likely acclimated to the current ambient noise

and light, due to the industrial nature, and heavy ship traffic of the SNWW. Therefore, impacts on aquatic species due to nighttime lighting and industrial noise during construction and operation would be negligible when taken into account with the existing environment of the area. Furthermore, Golden Pass would direct any nighttime lights on the activity being conducted to ensure the safety of workers and away from aquatic resources.

#### Golden Pass Import Terminal Ship Slip

The Terminal Expansion includes use of the existing Ship Slip for transfer of lighter construction materials prior to completion of the Supply Dock. To facilitate vessel movements, six marine dolphins, two for mooring and four for breasting, would be installed in the Ship Slip from a deck barge. Offshore piles would be vibrated until refusal and then driven with a hammer pile driver to the final depth as determined by load. The occurrence of these activities in water would generate underwater sound waves that could adversely affect nearby marine organisms. Depending on the sound frequency and intensity, this activity could cause a change in aquatic species behavior, including avoidance of the area. Based on Golden Pass' proposed construction methods, aquatic species behavior may be affected, but these species are likely to move out of the area temporarily and return once construction activities have ceased. Therefore, impacts on aquatic species from pile driving activities would be temporary, localized, and minor.

Maintenance dredging of the Ship Slip has been permitted for the existing terminal operations and would continue periodically during the life of the expanded terminal. Maintenance dredging would result in localized, short-term impacts on water quality and the benthic community, and Golden Pass would adhere to any COE permit requirements to minimize impacts.

#### Hydrostatic Testing

Golden Pass would hydrostatically test piping associated with the Terminal Expansion to ensure the integrity of the installed pipe prior to initiating operations. All hydrostatic test water would be obtained from a municipal water source. The discharge of hydrostatic test water could cause localized turbidity in the SNWW. However, Golden Pass would discharge hydrostatic test water in accordance with its state discharge permit and FERC's Procedures to minimize localized turbidity, erosion, and flooding.

With the use of municipal water sources and preventative BMPs for discharge, impacts on aquatic resources from hydrostatic testing would be temporary and negligible. Hydrostatic testing is discussed in further detail in section 4.3.2.2.

#### Firewater Intake Structure

The existing terminal includes a firewater intake structure located on the SNWW shoreline. However, this structure was abandoned in place due to heavy siltation making it inoperable. To minimize impacts on aquatic resources from the abandoned structure, Golden Pass would implement periodic visual inspections to ensure that the original intake structure does not deteriorate to an extent wherein it may become a potential hazard. Should that determination be made, the hazardous portion of the system would be removed. Removal likely would result in negligible effects to the SNWW and surrounding aquatic resources.

In February 2013, a temporary firewater intake structure was commissioned on the east side of the Ship Slip. Golden Pass would replace the temporary intake structure with a new, permanent structure in the same area for the Terminal Expansion. The firewater intake structure would include a 60-inch-diameter pipe extending to a depth of approximately -15 feet in the eastern berth of the Ship Slip (overall water depth at this location is about -25 feet [NAVD 88]).

To minimize potential effects to aquatic resources, Golden Pass would implement the following measures with the proposed firewater intake pipe to prevent entrainment and impingement of aquatic resources:

- The firewater intake pipe would be outfitted with double screens to avoid and minimize entrainment of aquatic resources in the Ship Slip.
- Golden Pass would provide pipe support with support structures to maintain the pipe in the middle of the water column, with at least 10 feet clearance both above and below the pipe. This positioning should prevent entrainment of both sediments and near-surface organisms.
- The firewater system would be restricted to operations only for emergency purposes and required maintenance activities.

Impacts on fisheries and aquatic resources associated with the proposed firewater intake structure would be negligible and temporary.

#### Vessel Activity

Use of the Supply Dock for material transfer would lead to increased vessel traffic in the Project area. Increased barge movements and movements of support and supply vessels during construction of the Terminal Expansion are not expected to substantially increase shoreline erosion, benthic sediment disturbance, or propeller scouring in the immediate area. These impacts are not expected primarily because the vessels are slow moving, do not create substantial wakes, and would be transiting through waterways maintained for large ship traffic. However, some benthic sediment disturbance could occur during barge loading and offloading. In addition, vessel groundings, although possible, are not likely because of the slow movement of the barges and the maintained depths of the SNWW. Therefore, impacts on aquatic species associated with increased barge traffic during construction would be short term and minor.

Use of the Supply Dock by construction vessels also could result in potential impacts from the inadvertent introduction of invasive species. However, vessels calling on the site during construction and operation would be barges and tugs that would not discharge ballast water. In addition, mostly local vessels would be used during construction of the Terminal Expansion, and the potential for invasive species introduction via hull attachment on these vessels would be negligible. Therefore, we do not anticipate impacts associated with the introduction of invasive species during construction of the Terminal Expansion.

Use of the Golden Pass Import Terminal Ship Slip could affect aquatic resources from increased barge movements and movements of support and supply vessels during construction. These impacts would be similar to those described for construction vessels calling on the Supply Dock. Potential impacts include potential sediment disturbance and potential introduction of invasive species; however, we anticipate that these impacts would be negligible. The total number of vessel transits to the site during operation of the Terminal Expansion would not exceed the number currently permitted at the existing Golden Pass Import Terminal. Operational impacts resulting from vessel traffic would be similar to those described for construction-related impacts; potential impacts include localized noise, exacerbation of shoreline erosion due to vessel wakes, benthic sediment disturbance, and introduction of invasive species via ballast water (see section 4.6.3.1).

During operation of the Terminal Expansion, vessels loading LNG would need to discharge ballast water at the terminal berth. All vessel operators would discharge ballast water in compliance with the EPA and the Coast Guard regulations intended to protect water quality. Ballast water discharges would occur periodically throughout the life of the Project and are anticipated to range from 7 to 15 million gallons, but any impact on water quality would be localized and temporary. Estuarine species common to the SNWW are relatively tolerant of fluctuating environmental conditions. Ballast water discharges to accommodate

LNG loading also would have the potential to introduce exotic or invasive species to the SNWW. Vessels calling on the expanded terminal would be required to adhere to the EPA and the Coast Guard regulations that prevent the introduction of exotic species such as:

- limiting the concentration of living organisms in ballast water;
- washing anchors and anchor chains to remove organisms at their point of origin;
- removing fouling organisms;
- cleaning ballast tanks regularly; and
- disposing of any waste in accordance with regulations.

Based on implementation of these procedures and adherence to federal regulations, impacts from ballast water discharges on aquatic species and introduction of exotic species would be minimized.

#### Stormwater Management

Following construction, the conversion of land to impervious surface areas at the Terminal Expansion site would result in an increased volume of stormwater runoff, which could create changes in salinity, temperature, and/or dissolved oxygen in the area surrounding discharges. Golden Pass would modify the existing stormwater management system to accommodate runoff from the expanded terminal in compliance with its NPDES permit. Impacts from increased stormwater runoff are expected to occur only during storm events and result in a negligible impact on aquatic resources.

#### Inadvertent Spills

Water quality could be adversely affected by an accidental spill of hazardous material into or near a waterbody. To minimize the potential for petroleum or hazardous materials spills from land equipment or vessels berthed at the Supply Dock or Ship Slip during construction, Golden Pass would implement measures in its SPCC Plan, which include spill prevention and response guidelines to reduce response time in the event of a release and expedite an efficient cleanup. During operation of the Terminal Expansion, Golden Pass also would implement spill prevention safeguards to minimize the potential for an inadvertent release of LNG during ship loading, vessel operations, and related activities. Additional information on the operational procedures implemented to minimize the likelihood of an LNG release, and to minimize impacts if one were to occur, is provided in section 4.12.

The Project design and measures in Golden Pass' SPCC Plan along with those outlined in section 4.12 would result in minimal risk of a release, and impacts on aquatic resources are not expected to be significant if a release were to occur.

### **4.6.3.2 Pipeline Expansion**

#### **Existing Aquatic Resources**

The three waterbodies along the proposed route include an agricultural ditch and two roadside drainage ditches (see table 4.3-3). These ditches are classified as warm, freshwater fisheries. No known commercial fisheries or recreational fishing occur in the vicinity of the Pipeline Expansion. The closest perennial stream that is reported to support recreational fisheries is 0.25 mile from the MP 66 Compressor Station. No sensitive fish species, fisheries of concern, or EFH have been identified within the waterbodies that would be affected by the Pipeline Expansion. The representative aquatic species that may be present in these ditches are presented in table 4.6.3-1.

## **Aquatic Resources Impacts and Mitigation**

### Waterbody Crossings

In general, impacts on fisheries resulting from pipeline construction activities at waterbody crossings could include sedimentation and turbidity, alteration or removal of in-stream and stream bank cover, and introduction of water pollutants. Based on Golden Pass' plans and our recommendation in section 4.3.2, Golden Pass would use open-cut methods for all three crossings (see section 2.6.3). An open-cut crossing would result in short-term increases in turbidity and siltation downstream of the pipeline crossing site. The concentration of suspended solids would decrease rapidly after completion of in-water work, but the increased siltation may cause degradation of benthic habitat and decreased flow of oxygenated water to benthic organisms. Direct loss of benthic invertebrates and protective cover may occur at the pipeline crossing location due to trenching and backfilling in the creek bed. In addition to our recommendation to avoid filling the drainage ditches, Golden Pass would construct all waterbody crossings in accordance with the construction and mitigation measures in FERC's Procedures, which require completion of in-water work within 24 hours for waterbodies 10 feet wide or less. To provide greater protection for warmwater fisheries, Golden Pass would complete construction activities between June 1 and November 30, unless expressly permitted in writing by the appropriate state agencies. In addition, excavated material would be stored within the right-of-way above the bank and at least 10 feet from the water's edge. Golden Pass would install temporary erosion control devices around piles of excavated material to minimize the potential for sediment-laden water to enter the ditches. With implementation of our recommendation for restoring the drainage ditches and measures in FERC's Procedures, impacts on aquatic resources would be temporary, localized, and minor.

### Hydrostatic Testing

Hydrostatic testing of the Pipeline Expansion would be similar to that for the Terminal Expansion (see sections 4.3.2.2 and 4.6.3.1)—except that water would be discharged to upland areas using an energy-dissipating device to minimize erosion—and in accordance with the LDEQ discharge requirements and FERC's Procedures. As a result, impacts on aquatic resources from hydrostatic testing would be temporary and minor.

### Inadvertent Spills

Water quality could be adversely affected by an accidental spill of hazardous material into or near a waterbody; however, with strict adherence to FERC's Procedures, SPCC Plan, and SWPPP in addition to all permit and agency requirements, impacts if spills on aquatic resources associated with construction and operation of the Pipeline Expansion would be minimal.

#### **4.6.4 Essential Fish Habitat**

One of the goals of the MSFCMA, as amended in 1996, is promoting the protection of EFH in the review of projects conducted under federal permits, licenses, or other authorities that affect or have the potential to affect such habitat. EFH is defined in the MSFCMA as those waters and substrate necessary to fish for spawning, breeding, feeding, or growth to maturity. All estuaries and estuarine habitats in the northern Gulf of Mexico are considered EFH (GMFMC, 2010a).

Federal agencies that authorize, fund, or undertake activities that may adversely affect EFH must consult with NOAA Fisheries. Although absolute criteria have not been established for conducting EFH consultations, NOAA Fisheries recommends consolidating EFH consultations with interagency coordination procedures required by other statutes, such as NEPA and the ESA, to reduce duplication and improve efficiency. Generally, the EFH consultation process includes the following steps:



- Notification – The action agency should clearly state the process being used for EFH consultations (e.g., incorporating EFH consultation into the EIS).
- EFH Assessment – The action agency should prepare an EFH Assessment that includes both identification of affected EFH and an assessment of impacts. Specifically, the EFH should include a description of the proposed action; an analysis of the effects (including cumulative effects) of the proposed action on EFH, the managed fish species, and major prey species; the federal agency's views regarding the effects of the action on EFH; and proposed mitigation, if applicable.
- EFH Conservation Recommendations – After reviewing the EFH Assessment, NOAA Fisheries would provide recommendations to the action agency regarding measures that can be taken by that agency to conserve EFH.
- Agency Response – The action agency must respond to NOAA Fisheries within 30 days of receiving recommendations from NOAA Fisheries. The response must include a description of measures proposed by the agency for avoiding, mitigating, or offsetting the impacts of the activity on EFH.

Based on the presence of freshwater and a lack of identified EFH along the Pipeline Expansion route, only potential impacts associated with construction and operation of the Terminal Expansion are discussed in this section. The FERC previously prepared an EIS to assess construction and operation impacts on EFH and EFH species associated with the existing Golden Pass Import Terminal (FERC, 2005). As a part of the 2005 environmental review, the FERC consulted with NOAA Fisheries regarding potential impacts on EFH related to construction of the Golden Pass Import Terminal, dredging the berthing area, loss of estuarine emergent wetlands within the terminal footprint, accidental releases of LNG, and the number of LNG carriers and transit routes. We determined, and NOAA Fisheries agreed, that based on implementation of conservation measures and the compensatory mitigation plan developed by Golden Pass, no substantial adverse impacts on EFH or EFH species would occur related to construction and operation of the original Golden Pass Import Terminal. We have received no information from NOAA Fisheries on whether this determination would continue to be valid for the currently proposed Project, especially for the SNWW and associated EFH species.

The FERC proposes to incorporate EFH consultations for the Terminal Expansion facilities with the interagency coordination procedures required under NEPA. As such, we are requesting that NOAA Fisheries consider the EIS as initiation of EFH consultation and to provide its recommendations to further reduce potential impact on EFH.

#### **4.6.4.1 Characterization of Essential Fish Habitat**

NOAA Fisheries and the Gulf of Mexico Fishery Management Council (GMFMC) have identified the SNWW as EFH for multiple recreational and commercial marine species. The EFH that may be affected by the Terminal Expansion includes estuarine water bottom (soft bottom sediment) and estuarine water column. The estuarine water bottom habitat in and near the Project area includes subtidal mud and sand bottoms. The habitat does not include submerged aquatic vegetation or intertidal marsh, which serves as potential nursery and feeding areas for many fish and invertebrates—including species living on and in the sediments. The biological community of the estuarine bottom habitat remains in an early successional stage because of regular disturbance from maintenance dredging. Estuarine water column habitat serves as EFH for several species and their prey at various life stages by providing habitat for spawning, breeding, and foraging. Biological communities within the water column are acclimated to the level of disturbance within the SNWW and are dictated by salinity, temperature, and dissolved oxygen regimes.

EFH species listed for the Project area include brown shrimp, white shrimp, red drum, and coastal migratory species. Based on review of available life history information, fishery management plans, the location of the Terminal Expansion, and previous and ongoing projects conducted in the vicinity of the Terminal Expansion, we believe that the Terminal Expansion would not adversely affect coastal migratory species in the area, such as Spanish mackerel and bluefish (GMFMC, 2010a). These species/complexes are not addressed further in this EIS. Species and life stages that may be present in the Terminal Expansion workspace during construction or operation are listed in table 4.6.3-2.

<b>TABLE 4.6.3-2</b>			
<b>Essential Fish Habitat Species In Waterbodies Affected by the Terminal Expansion</b>			
<b>Common Name</b>	<b>Scientific Name</b>	<b>Life Stages in Estuarine Habitat</b>	<b>Comment</b>
Brown shrimp	<i>Farfantepenaeus aztecus</i>	Post-larval, juvenile, adult	EFH present in Project vicinity
White shrimp	<i>Litopenaeus setiferus</i>	Post-larval, juvenile, adult	EFH present in Project vicinity
Red drum	<i>Sciaenops ocellatus</i>	Juvenile, adult	EFH present in Project vicinity

#### **4.6.4.2 Essential Fish Habitat Species Descriptions**

##### **Brown Shrimp**

Brown shrimp spawn in offshore marine environments, producing demersal eggs that hatch into planktonic larvae. Brown shrimp spawn throughout the year; however, peak spawning season occurs in spring and summer when bottom waters range in temperature from 17 to 29°C. Adults also are known to die after spawning once (Larson, 1989). Post-larvae migrate to estuarine habitats on flood tides from February to April. Post-larval and juvenile brown shrimp are common in Gulf of Mexico estuaries from Apalachicola Bay, Florida, to the Mexican border year-round except from December to February. Typically associated with shallow vegetated habitats, silty sand, and non-vegetated mud bottom with salinities from 0 to 70 parts per thousand, post-larval and juvenile brown shrimp are most abundant in marsh edge habitat and submerged vegetation. Once mature, they migrate back to open water to spawn. Larval brown shrimp feed on phytoplankton and zooplankton; post-larvae feed on epiphytes, phytoplankton, and detritus; and juveniles and adults prey on polychaetes, amphipods, chironomid larvae, algae, and detritus (GMFMC, 2010b; NOAA, 2014b).

##### **White Shrimp**

White shrimp spawn in nearshore marine environments, producing demersal eggs that hatch into planktonic larvae. White shrimp can spawn up to four times in their lifespan, usually from March to November (Muncy, 1984). Post-larvae migrate to estuarine habitats from May to November, peaking in June to September. Post-larval and juvenile brown shrimp are common in Gulf of Mexico estuaries from the Suwannee River in Florida to Texas year-round. Juvenile white shrimp typically are associated with shallow-water estuarine habitats and muddy-sandy substrates; highest densities are found along marsh edges and within submerged aquatic vegetation. Once mature, they migrate back to open water in late August and September to spawn. Larval white shrimp feed on phytoplankton and zooplankton; post-larvae feed on epiphytes, phytoplankton, and detritus; and juveniles and adults prey on polychaetes, amphipods, chironomid larvae, algae, and detritus (GMFMC, 2010b; NOAA, 2014c).

## **Red Drum**

Red drum tolerate a wide range of salinities and commonly occur in estuaries throughout the Gulf of Mexico year-round; they are present over a variety of substrates, including sand, mud, and oyster reefs. Estuaries are important as nursery habitat for larval, juvenile, and sub-adult red drum, and also serve as foraging habitat for all life stages. Larval red drum forage on mysids, amphipods, and shrimp; juveniles feed on crabs and fish; and adults forage on crustaceans, including shrimp and crabs, and fish (GMFMC, 2010b; TPWD, 2014a).

### **4.6.4.3 Essential Fish Habitat Impacts and Mitigation**

#### **Terminal Expansion Construction**

The primary construction-related impact at the Terminal Expansion site would be related to filling wetland areas, as described in section 4.4. The potential for these land-based activities to affect EFH would be negligible; therefore, this EFH Assessment focuses on activities associated with construction and use of the Supply Dock and installation of marine dolphins at the Ship Slip. Other Project-related activities with the potential to affect EFH include discharge of hydrostatic test water, an accidental release of petroleum products during construction, and increased sound levels and lighting at the Supply Dock and Ship Slip work areas. The potential effects of these activities on EFH and EFH species are discussed below.

As shown in table 4.6.3-1, certain life stages of the brown shrimp, white shrimp, and red drum potentially could be affected by aspects of construction of the Terminal Expansion. No spawning, egg stage, or adult habitat of these species would be affected by the Terminal Expansion because these habitats occur offshore.

All phases of construction and operation of the Supply Dock could affect EFH or EFH species, but dredging would present the greatest potential impact. Dredging would cause temporary sediment suspension and turbidity, lowering the water quality within a localized area surrounding dredging activities. As discussed in section 4.6.3.1, increases in turbidity can adversely affect fish physiology and behavior, resulting in less healthy individuals, reductions in fecundity, and reduced foraging. All three managed EFH species could be present during active dredging. Golden Pass would minimize sedimentation through the use of a cutterhead dredge, as discussed in section 4.6.3.1. Furthermore, the SNWW has high suspended sediment loads due to existing heavy vessel traffic and maintenance dredging. Therefore, the increase in turbidity from dredging the Supply Dock area would be minor, temporary, and localized to the area immediately surrounding the Supply Dock. Based on the mitigation measures proposed and the abundance of suitable habitat in adjacent areas, the impacts of dredging on EFH or EFH species in the water column would be temporary and minor.

Another aspect of dredging that could affect EFH or EFH species is disturbance of the estuarine water bottom habitat in the Project area. During dredging, the benthic community would be reduced in species richness, species abundance, and biomass through direct mortality. This would reduce the amount of prey available for the EFH species in the Project area; however, polychaetes, oligochaetes, and other similar species would quickly recolonize disturbed areas following dredging. Through natural processes and rapid population growth, these species take advantage of unoccupied space in newly exposed sediments (MMS, 2004). Based on published data, we anticipate that dredging would result in a negligible temporary impact on the benthic community. Therefore, impacts on EFH species also would be negligible, as the species could forage in other nearby EFH areas and return to the Supply Dock area after repopulation of the prey base.

Installation of the pilings for the Supply Dock and marine dolphins in the existing Ship Slip could cause rapid concussive noise underwater. Depending on the sound frequency and intensity, this activity

could cause a change in aquatic species behavior, including avoidance of the area. Use of shore-based equipment to install the sheet pilings associated with the Supply Dock prior to dredging would reduce in-water noise impacts; however, about 10 offshore pilings at the Ship Slip would be driven from a deck barge. Based on Golden Pass' proposed construction methods, EFH species behavior may be affected, but these species are likely to move out of the area temporarily during active pile driving and return once noise-generating activities have ceased. Therefore, the impacts on EFH species from noise would be temporary, localized, and minor.

During construction of the Supply Dock, additional lighting would be installed and used at the construction site. Aquatic species in the area are likely acclimated to the current ambient light from the existing Golden Pass Import Terminal and the industrial nature of the SNWW. Therefore, any impacts on EFH species due to nighttime lighting during construction would be minor, given the proximity of the existing terminal to the Supply Dock. Certain EFH species may be drawn to light outside the immediate construction area and may be subject to increased predation. However, impacts would not occur at the population level.

The increase in barge traffic at and near the Supply Dock during construction would result in a short-term increase in vessel traffic and noise in the area. During operation, barges would periodically deliver supplies or facilitate maintenance dredging in the berthing and Supply Dock areas. Barge movements and movements of support and supply vessels are not expected to substantially increase shoreline erosion, benthic sediment disturbance, or propeller scarring—primarily because the vessels are slow moving and do not create substantial wakes. In addition, underwater noise generated by large vessels calling on the Supply Dock would increase during construction. However, noise levels of vessels calling on the Supply Dock would be similar to the noise currently generated by vessels transiting the SNWW. Based on these considerations, increased barge traffic and noise would be consistent with current vessel traffic noise occurring in proximity to the Terminal Expansion, and associated impacts on EFH and EFH species would not be significant.

Hydrostatic testing of the Terminal Expansion piping would use a municipal water source; therefore, no impacts on EFH would result from water intake. Discharge of the freshwater hydrostatic test water into the SNWW could cause localized turbidity and minor changes in salinity and temperature. Golden Pass would conduct discharges in accordance with its state discharge permit and FERC's Plan and Procedures to minimize localized turbidity and erosion. Biocides or oxygen scavengers would not be used. Use of these measures would result in temporary and negligible impacts on EFH and EFH species in the form of minimal water and sediment disturbance during discharge. The impact would dissipate shortly after completion of hydrostatic discharge activities. Section 4.6.3.1 provides additional information on hydrostatic testing for the Terminal Expansion.

To minimize the potential for petroleum product spills during construction and operation, Golden Pass would implement spill prevention procedures and clean-up measures described in its SPCC Plan, which includes spill prevention and response guidelines. Implementation of these procedures would minimize response time and ensure that appropriate clean-up actions are taken in the event of a spill. Therefore, we believe that impacts from a spill would be minimized.

### **Terminal Expansion Operations**

Operational impacts at the Terminal Expansion site could occur for the duration of the Project. Potential impacts would be associated with maintenance dredging at the Ship Slip and Supply Dock; vessels calling on the expanded terminal; increased runoff from the expanded terminal; and inadvertent releases, including LNG. Impacts related to maintenance dredging during operation of the Terminal Expansion would be similar to those described for construction-related dredging. All three managed EFH species could be present during maintenance dredging at the Ship Slip and Supply Dock. Based on the mitigation

measures proposed, the abundance of suitable habitat in adjacent areas, and the periodic ongoing dredging of the SNWW conducted by the COE, additional impacts on EFH or EFH species from maintenance dredging of the Ship Slip would be negligible.

The total number of vessel transits to the site during operation of the expanded terminal would not exceed the number currently permitted (and previously analyzed) at the existing Golden Pass Import Terminal. Operational impacts resulting from vessel traffic would be similar to those described for construction-related impacts. Potential impacts include localized noise, potential exacerbation of shoreline erosion due to vessel wakes, benthic sediment disturbance, and introduction of invasive species via ballast water (see section 4.6.3.1). However, LNG carriers visiting the Terminal Expansion would discharge ballast water during the loading of LNG. Discharge of ballast water would be conducted in accordance with the EPA and the Coast Guard regulations intended to protect water quality. Based on the mitigation measures proposed, the baseline vessel traffic in the SNWW, and the generally slow movement of vessels calling on the Ship Slip, operational impacts associated with vessels calling on the expanded terminal would not be significant.

Following construction, conversion of land to impervious surface areas at the Terminal Expansion site would result in an increased volume of stormwater runoff, which could create changes in salinity, temperature, and/or dissolved oxygen in the area surrounding discharges. Golden Pass would modify the existing stormwater management system to accommodate runoff from the expanded terminal in compliance with its NPDES permit. Impacts from increased stormwater runoff are expected to occur only during storm events and result in a negligible impact on water quality, EFH, and EFH species.

During operation of the Terminal Expansion, Golden Pass would implement spill prevention safeguards to minimize the potential for an inadvertent release of LNG during ship loading and related activities. Based on these procedures and the naturally rapid vaporization of LNG into non-toxic, atmospheric methane, we believe that impacts on EFH and EFH species would be negligible.

#### **4.6.4.4 Essential Fish Habitat Conclusions**

Although construction of the Supply Dock would involve permanent conversion of shoreline and shallow subtidal habitat to open water, causing direct mortality to benthic organisms, the deepened area would recolonize with soft-bottom benthic organisms soon after completion of dredging, which would provide a prey base for EFH species (MMS, 2004). This temporary impact would re-occur with regular maintenance dredging. These events represent a minor increase in the already periodic nature of elevated turbidity due to ongoing maintenance dredging throughout the SNWW. The area temporarily affected for construction and operation of the Supply Dock would be negligible in terms of the three EFH species in the area when considering the amount of similar intertidal, subtidal, and open water habitat available in the immediate vicinity.

To minimize impacts on EFH species from dredging, Golden Pass would use a cutterhead dredge for initial and maintenance dredging. In addition, Golden Pass would adhere to FERC's Plan and Procedures, and the SPCC Plan, which includes spill prevention and response procedures. Dredged material would be transported to an upland disposal area per the DMMP (see appendix I). Increased stormwater runoff from conversion of wetlands and uplands to impervious cover would be mitigated by measures described in Golden Pass' SWPPP and in compliance with its NPDES permit. Impacts on brown shrimp and white shrimp would be limited to the post-larval and juvenile stages, as both stages occur in estuaries similar to the habitat present at the Supply Dock site. Brown shrimp are present year-round, while white shrimp are present in the estuary between May and November. Direct mortality could occur during active dredging; however, individuals are mobile and many could avoid the construction area. After dredging, and until conditions are conducive for repopulation, individuals would use adjacent areas with suitable EFH. Impacts on white and brown shrimp and their prey species from each of these construction activities

are expected to be temporary and localized due to Golden Pass' construction methods and mitigation measures. Impacts on white and brown shrimp from operation of the Terminal Expansion are expected to be temporary to short term when they do occur, and similar to baseline impacts within the SNWW. Therefore, we do not anticipate any substantial adverse effects to white or brown shrimp related to construction or operation of the Terminal Expansion.

Red drum occur year-round in estuaries associated with the Gulf of Mexico, and juvenile and sub-adult red drum are likely to be present in the SNWW throughout construction and operation of the Terminal Expansion. Direct mortality could occur during active dredging; although individuals would likely avoid the area during construction of the Supply Dock and use other EFH areas nearby. Operation of the Terminal Expansion would not likely impede population growth of red drum in the area. Prey species for red drum would recolonize quickly after construction and dredging are completed. In addition, impacts from construction and operation are expected to be localized and temporary to short term when they do occur. Therefore, we do not anticipate any substantial adverse effects to red drum.

Based on review of species' habitats and life histories, implementation of Golden Pass' conservation measures, and the Draft Compensatory Mitigation Plans developed by Golden Pass, we believe that no adverse impacts on EFH or EFH species would occur during construction or operation of the Terminal Expansion.

#### **4.7 THREATENED AND ENDANGERED SPECIES**

Federal agencies are required by Section 7 of the ESA of 1973 to consult with the FWS in order to ensure that any action they authorize, fund, or carry out would not jeopardize the continued existence of a species federally listed as threatened or endangered, or a species proposed for listing. As the lead federal agency, the FERC is responsible for the Section 7 consultation with the FWS. In accordance with Section 380.13(b) of the FERC's Order 603, the Project sponsor is designated as the FERC's non-federal representative for purposes of informal consultation with the FWS. In compliance with Section 7 of the ESA, Golden Pass, acting as the FERC's non-federal representative, initiated informal consultation with the FWS, NOAA Fisheries, the TPWD, and the LDWF regarding federally and state-listed and other special-status species or habitat with the potential to be affected by construction and operation of the Project (LDWF, 2013; TPWD, 2013; FWS, 2013a, 2013b, 2013c, 2014a). In addition, the FERC is required to consult with the FWS and NOAA Fisheries to determine whether any critical habitats for species federally listed as endangered or threatened are in the vicinity of the Project, and to determine the potential effects of the proposed action on those species and critical habitats. No critical habitat for federally listed species was identified in the Project area. In consultation with the FWS, NOAA Fisheries, the TPWD, and the LDWF, Golden Pass initially identified 41 species with the potential to occur in the Project area. Of these species, 21 would not be affected by the Project and thus are not addressed further in this EIS. The remaining 20 species with the potential to occur in the Project area are listed in tables 4.7-1 and 4.7-2 and discussed below. Golden Pass conducted surveys in July, August, and November 2013. During these surveys, no special-status species were observed (federal, state, candidate, or other special-status species).

**TABLE 4.7-1**

**Federally-listed Species Potentially Occurring in the Vicinity of the Golden Pass LNG Export Project**

<b>Common Name</b>	<b>Scientific Name</b>	<b>Listing County/ Parish</b>	<b>Project Component</b>	<b>Federal Status <sup>a</sup></b>	<b>Texas State Status <sup>a</sup></b>	<b>Louisiana State Status <sup>a</sup></b>	<b>Determination</b>	<b>Comments</b>
Piping plover	<i>Charadrius melodus</i>	Jefferson and Orange	Terminal	T	T	T	<i>Not likely to adversely affect</i>	Suitable habitat may be present in the Project area.
Sprague's pipit	<i>Anthus spragueii</i>	Jefferson and Orange; Calcasieu	Pipeline	C	-	-	<i>Not likely to adversely affect</i>	Suitable habitat may be present in the Project area.
American alligator	<i>Alligator mississippiensis</i>	Jefferson and Orange; Calcasieu	Terminal	T (S/A)	-	-	<i>Not likely to adversely affect</i>	Suitable habitat may be present in the Project area.
Atlantic hawksbill sea turtle	<i>Eretmochelys imbricate</i>	Jefferson	Terminal	E	E	-	<i>Not likely to adversely affect</i>	Suitable habitat may be present in the Project area.
Green sea turtle	<i>Chelonia mydas</i>	Jefferson	Terminal	T	T	-	<i>Not likely to adversely affect</i>	Suitable habitat may be present in the Project area.
Kemp's ridley sea turtle	<i>Lepidochelys kempii</i>	Jefferson	Terminal	E	E	-	<i>Not likely to adversely affect</i>	Suitable habitat may be present in the Project area.
Leatherback sea turtle	<i>Dermochelys coriacea</i>	Jefferson	Terminal	E	E	-	<i>Not likely to adversely affect</i>	Suitable habitat may be present in the Project area.
Loggerhead sea turtle	<i>Caretta</i>	Jefferson	Terminal	T	T	-	<i>Not likely to adversely affect</i>	Suitable habitat may be present in the Project area.

Species lists from the FWS, the TPWD, and the LDWF Species List by County.  
 Sources: BES, 2013c, 2013d  
Abbreviations:  
<sup>a</sup> E = endangered, T = threatened, C = candidate, S/A = listed because of similarity of appearance

TABLE 4.7-2

## State Special-Status Species Potentially Occurring in the Vicinity of the Golden Pass LNG Export Project

Common Name	Scientific Name	Listing County/ Parish	Project Component	Texas State Status <u>a</u>	Louisiana State Status <u>a</u>	Determination
American peregrine falcon	<i>Falco peregrinus anatum</i>	Jefferson and Orange	Terminal	T	-	No significant impact
Bald eagle	<i>Haliaeetus leucocephalus</i>	Jefferson and Orange, Calcasieu	Terminal, Pipeline	T	E	No significant impact
Peregrine falcon	<i>Falco peregrinus</i>	Jefferson and Orange	Terminal	T	T	No significant impact
Reddish egret	<i>Egretta rufescens</i>	Jefferson	Terminal	T	-	No significant impact
Swallow-tailed kite	<i>Elanoides forficatus</i>	Jefferson and Orange	Terminal, Pipeline	T	-	No significant impact
White-faced ibis	<i>Plegadis chihi</i>	Jefferson and Orange	Terminal	T	-	No significant impact
Wood stork	<i>Mycteria Americana</i>	Jefferson and Orange	Terminal	T	-	No significant impact
Rafinesque's big-eared bat	<i>Corynorhinus rafinesquii</i>	Jefferson and Orange	Pipeline	T	-	No significant impact
Alligator snapping turtle	<i>Microcells temminckii</i>	Jefferson and Orange	Terminal	T	RH	No significant impact
Texas diamondback terrapin	<i>Malaclemys terrapin littoralis</i>	Jefferson and Orange	Terminal	SC	RH	No significant impact
Gulf salt marsh snake	<i>Nerodia clarkia</i>	Jefferson and Orange	Terminal	SC	-	No significant impact
Timber/canebrake rattlesnake	<i>Crotalus horridus</i>	Jefferson and Orange	Terminal, Pipeline	T	-	No significant impact
Species lists from the FWS, the TPWD, and the LDWF Species List by County. Sources: BES, 2013c, 2013d <u>Abbreviations:</u> <u>a</u> E = endangered, T = threatened, C = candidate, SC = species of concern, RH = restricted harvest						



#### **4.7.1 Federally Listed Threatened and Endangered Species**

We identified eight species (see table 4.7-1) that are federally listed as threatened, endangered, or candidate with the potential to occur in the Project area. Three of these species are under the jurisdiction of the FWS (piping plover, Sprague's pipit, and American alligator), and five species are under the jurisdiction of NOAA Fisheries (sea turtles).

##### **4.7.1.1 Piping Plover**

The piping plover is federally listed as threatened and state listed as threatened in Texas and Louisiana (BES, 2013c, 2013d; LDWF, 2014). The piping plover is a migratory species that winters in Atlantic and Gulf coastal regions of the United States and several Caribbean islands; the plover breeds in the northern United States and Canada (Cornell University, 2011b). This species forages in wide, flat, open, sandy beaches; nesting occurs on open beaches near small creeks or wetlands (Cornell University, 2011b; TPWD, 2014c). Piping plovers feed on insects, spiders, and crustaceans that occur on open beaches or mudflats. In Texas, the piping plover has been observed along the entire Gulf Coast but is most abundant in lower Laguna Madre (TPWD, 2014c). Threats to this species include habitat loss and degradation, particularly of coastal beaches, and nest disturbance and predation.

During winter, this species could be present along the shoreline in the vicinity of the Terminal Expansion site, in open mudflats or beaches. Based on Golden Pass' survey information and aerial imagery interpretation, those shoreline types are not currently present at the Terminal Expansion, including the adjacent SNWW shoreline. Further, the existing industrialized land use near the Terminal Expansion site would limit the likelihood that the species would use the small amount of existing shoreline. Piping plovers could transit through the area during construction of the Terminal Expansion; however, they likely would avoid the area because of the high level of activity. Therefore, we conclude that construction and operation of the Terminal are *not likely to adversely affect* the piping plover.

##### **4.7.1.2 Sprague's Pipit**

The Sprague's pipit is a federally listed candidate species (BES 2013c, 2013d). It is a short-duration migrant that winters in the southern United States and northern Mexico, and breeds in the northern United States and Canada (FWS, 2014b). Sprague's pipit prefers open grassland habitat with native grasses of intermediate height and thickness; they tend to avoid areas with shrub encroachment. The species inhabits mixed-grass prairie; it feeds primarily on arthropods and a small amount of vegetation in the breeding season and on seeds on the wintering grounds. Threats to the species include habitat loss; nest predation; and prolonged cold, wet weather (FWS, 2014b).

During winter, this species could be present in open grassland areas in the Project vicinity, and could transit through the area during construction of the Project. However, they likely would temporarily avoid areas of high activity. Based on the limited open grassland habitat in the vicinity of the Project and the mobility of the species, we conclude that construction and operation of the Terminal are *not likely to adversely affect* the Sprague's pipit.

##### **4.7.1.3 American Alligator**

The American alligator is federally listed as threatened because of its similarity to the American crocodile (*Crocodylus acutus*) (BES 2013c, 2013d). The American alligator is common in swamps, rivers, bayous, and marshes throughout the southern United States. Breeding and nesting occurs from March to May; females lay eggs in large nests of mounded vegetation (TPWD, 2014d). Once near extinction, the American alligator has recovered and was delisted from endangered status in 1985.

Suitable foraging and nesting habitat potentially occurs in the vicinity of the Terminal Expansion, and abundant habitat is available in the Project area. Although no sightings occurred during field surveys, individuals have been removed from the Golden Pass Import Terminal property in the past. Based on the lack of sightings in the Project area, the species mobility, and the presence of suitable habitat outside the Project area, we conclude that construction and operation of the Terminal are *not likely to adversely affect* the American alligator.

#### **4.7.1.4 Sea Turtles**

Five species of sea turtles federally listed as endangered or threatened possibly occur in the waters near the Terminal Expansion in Jefferson County, Texas. The life histories of these species and potential impacts are described below.

##### **Green Sea Turtle**

The green sea turtle is federally listed as threatened (BES, 2013c, 2013d). Following hatching, green sea turtles spend their entire lives at sea; they inhabit shallow habitats with an abundance of marine algae and seagrass, such as lagoons, bays, inlets, shoals, and estuaries (NOAA, 2014d). They use coral reefs and rocky outcrops near feeding areas to rest; and they feed on marine plants, mollusks, sponges, crustaceans, and jellyfish. Mature females return to their natal beach to nest (NOAA, 2014d). Suitable nesting habitat for this species is not available in the vicinity of the Project; however, green sea turtles could transit through coastal inlet habitats such as the SNWW during foraging.

##### **Atlantic Hawksbill Sea Turtle**

The Atlantic hawksbill sea turtle is federally listed as endangered (BES, 2013c, 2013d). This species inhabits coastal reefs, bays, rocky areas, estuaries, and lagoons at depths of 70 feet or less and occasionally may be transient in Sabine Pass and the SNWW during foraging (NOAA, 2014e). Hawksbill sea turtle hatchlings may occur in the open sea, floating on masses of marine plants; juveniles, subadults, and adults may occur near their primary foraging area along coral reefs. Hawksbill sea turtles are omnivorous; however, they prefer to feed on invertebrates such as sponges, mollusks, and sea urchins (NOAA, 2014e). In contrast to all other sea turtle species, hawksbills nest in low densities on scattered small beaches. Due to the lack of suitable foraging and nesting habitats, there is a low probability of this species occurring in the Project area.

##### **Kemp's Ridley Sea Turtle**

The Kemp's ridley sea turtle is the smallest of the sea turtles found in the Gulf of Mexico and is federally listed as endangered (BES 2013c, 2013d). It occurs mainly in the coastal areas of the Gulf of Mexico and the U.S. Atlantic seaboard. Juveniles and sub-adults occupy shallow, coastal regions and commonly are associated with crab-laden, sandy, or muddy water bottoms; young turtles often float on mats of *Sargassum* seaweed (NOAA, 2014f). Kemp's ridley sea turtles feed mostly on swimming crabs, but their diet also includes fish, jellyfish, and mollusks. Although nesting occurs mainly in Mexico from May to July, Kemp's ridley sea turtles also nest in small numbers along the Gulf Coast, mostly in southern Texas (NOAA, 2014f). Nesting areas for the Kemp's ridley sea turtle are not present in or near the Terminal Expansion site; however, they may transit through Sabine Pass and the SNWW during foraging.

##### **Leatherback Sea Turtle**

The leatherback sea turtle is federally listed as endangered (BES 2013c, 2013d). Leatherback sea turtles spend most of their time in the open sea and come to land only to nest. They may be present in coastal waters when nesting or following jellyfish concentrations (NOAA, 2014g). They feed mainly on

jellyfish and sea squirts as well as sea urchins, crustaceans, fish, and floating seaweed; and they prefer sandy beaches with deepwater approach for nesting (NOAA, 2014g). Suitable foraging and nesting habitat for this species is not available in the vicinity of the Project.

### **Loggerhead Sea Turtle**

The loggerhead sea turtle is federally listed as threatened (BES, 2013c, 2013d). Loggerhead sea turtles inhabit continental shelves, bays, estuaries, and lagoons in temperate, subtropical, and tropical waters; they could occur in Sabine Pass and the SNWW during foraging and transit. Loggerheads were named for their relatively large heads, which support powerful jaws and enable them to feed on hard-shelled prey such as whelks and conch (NOAA, 2014h). Loggerhead sea turtles nest within the coastal United States from Louisiana to Virginia, with major nesting concentrations occurring on the coastal islands of North Carolina, South Carolina, and Georgia—and on the Atlantic and Gulf Coasts of Florida (NOAA, 2014h). Loggerheads are known to nest on the Texas Gulf Coast and the Chandeleur Islands of Louisiana; however, while suitable foraging habitat may exist for transiting loggerheads in the SNWW, no nesting habitat is present in the Project area.

### **Sea Turtle Impacts and Mitigation**

Although sea turtles are not likely to inhabit the area in the immediate vicinity of the Terminal Expansion and there are no known occurrences of sea turtles nesting in the Project area, the more coastal species occasionally may forage in and transit through the SNWW. Given the level of industrial activity in the vicinity of the Golden Pass Import Terminal, it is unlikely that sea turtle species would use any habitat near the Terminal Expansion, except possibly during occasional transit. If, however, sea turtles were present on occasion, they could avoid any sheet piling or pile driving activities and sedimentation from dredging activities. During in-water construction, Golden Pass would follow the *Sea Turtle and Smalltooth Sawfish Construction Conditions* (NOAA, 2006).

Aquatic resources may be affected during construction of the Supply Dock, installation of the receiving platform, bulkhead, access road, and staging areas. Although some construction activities would be completed by dry means, in-water dredging would occur. Dry construction would generate noise because it would take place close to the water's edge. Dredging activity would generate noise because it occurs within the water column. It is likely that sea turtles are able to hear anthropogenic sounds in their marine environment (Dow Piniak et al., 2014a, 2014b); however, impacts related to noise would be minor because of the short duration of construction. In addition, dredging activities associated with the Supply Dock would be minimal in comparison to the regular ongoing maintenance dredging in the channel. Based on the lack of preferred foraging and nesting habitat in the immediate vicinity of the Terminal Expansion and avoidance of the area because of current industrial activities, including dredging, sea turtles likely would continue to avoid the area.

During operation of the Terminal Expansion, sea turtles could be vulnerable to strikes from vessels calling on the expanded terminal. While in the SNWW, vessels would operate at reduced speed to minimize vessel strike hazards. Further, vessels would adhere to NOAA Fisheries' *Vessel Strike Avoidance Measures and Reporting for Mariners* (NOAA, 2008).

During site surveys, no suitable sea turtle nesting habitat, individual sea turtles, or sea turtle nests were observed. In addition, foraging and transit habitats for sea turtles are limited near the Terminal Expansion site.

## Effect Determination

Because sea turtles occur within the transit route for marine vessels, the potential exists for individual turtles to be negatively affected by vessel strikes due to the proposed increase in ship traffic during construction. However, we conclude the proposed Project is *not likely to adversely affect* the federally listed sea turtles described above because: (1) vessel strikes are unlikely, especially given that construction vessels, supply vessels during operation, and LNG carriers would adhere to NOAA Fisheries' *Vessel Strike Avoidance Measures and Reporting for Mariners* (NOAA, 2008); (2) the increase in annual ship traffic during construction is expected to cause an immeasurable increase for potential vessel strikes on sea turtles; (3) Golden Pass has not requested an increase in the number or size of LNG carriers currently calling on the existing terminal; and (4) the likelihood of a fuel spill or release of hazardous materials at sea would be extremely remote, and if a spill did occur, the carrier would implement spill prevention procedures and clean-up measures (e.g., SPCC Plan, which includes spill prevention and response guidelines).

### **4.7.2 State-listed and Other Special-status Species**

In consultation with the TPWD and the LDWF, we identified 18 additional species state listed as threatened or endangered or species of concern that could be affected by the Project (see table 4.7-2). The life histories of these species and potential impacts are described below.

#### **4.7.2.1 American Peregrine Falcon/Peregrine Falcon**

The American peregrine and peregrine falcon are state listed in Texas and Louisiana as threatened (BES, 2013c, 2013d; LDWF, 2014). The falcons migrate across the state from more northern breeding areas in the United States and Canada, and winter along the coast and farther south (FWS, 2006); they are considered transient within the Golden Pass Import Terminal property and J. D. Murphree WMA (TPWD, 2014e). The falcons occupy a wide range of habitats during migration, including urban areas; however, they typically are found foraging along the coast and barrier islands (FWS, 2006). Being low-altitude migrants; stopovers are at leading landscape edges, such as lake shores, coastlines, and barrier islands (TPWD, 2014e). They nest on ledges and in caves on high cliffs.

Suitable coastal foraging habitat is found at the Terminal Expansion site; however, suitable nesting habitat does not occur, and no individuals were observed during surveys. Based on the lack of sightings during field surveys, the abundance of suitable habitat in adjacent areas such as the J. D. Murphree WMA, and the species mobility, the Project would not significantly affect the American peregrine or peregrine falcon.

#### **4.7.2.2 Bald Eagle**

The bald eagle is state listed in Texas as threatened and in Louisiana as endangered (BES, 2013c, 2013d). The bald eagle could winter or breed in areas near the Terminal Expansion site and Pipeline Expansion route, and potential foraging habitat exists near the Terminal Expansion site and the Pipeline Expansion route. No nests were found during field surveys for the Project. Based on the lack of sightings, the species mobility, and Golden Pass' adherence to migratory bird protection measures, the Project would not significantly affect the bald eagle. Potential impacts on the bald eagle and migratory bird protection measures are discussed in section 4.6.1.3.

#### **4.7.2.3 Reddish Egret**

The reddish egret is state listed in Texas as threatened and is a permanent resident of the Texas Coast; the reddish egret is not listed in Louisiana (BES, 2013c, 2013d; LDWF, 2014). The wetland habitats in the vicinity of the Terminal Expansion offer potentially suitable foraging and nesting habitat for the

reddish egret. They forage in saltwater and brackish waters flats, and lagoons; they nest on bare ground near shrubs or on shell beaches (Audubon, 2014d; TPWD, 2014f).

While suitable habitat does occur at the Terminal Expansion site, no nests were observed during field surveys, and there are no known occurrences in the immediate vicinity of the Project. Based on the lack of known occurrences, the species mobility, and the abundance of suitable habitat in the vicinity of the Project, the Project would not significantly affect the reddish egret.

#### **4.7.2.4 Swallow-tailed Kite**

The swallow-tailed kite is state listed in Texas as threatened but is not listed in Louisiana (BES 2013c, 2013d; LDWF 2014). The swallow-tailed kite is a migratory species that nests near large rivers such as the Trinity and Sabine rivers and associated bottomland forests (TPWD, 2014g). Breeding occurs from March to June in the southeast part of Texas. In fall, they migrate to coastal prairies and into South America (Audubon, 2014e). Suitable foraging and nesting habitat potentially occurs in the vicinity of the Terminal Expansion and the Pipeline Expansion route; however, no sightings occurred during field surveys and there are no known occurrences in the vicinity of the Project. Therefore, based on the lack of sightings in the Project area, and the species mobility, the Project would not significantly affect the swallow-tailed kite.

#### **4.7.2.5 White-faced Ibis**

The white-faced ibis is state listed in Texas as threatened but is not listed in Louisiana (BES, 2013c, 2013d; LDWF, 2014). White-faced ibis habitat includes freshwater marshes, sloughs, and irrigated rice fields. These ibis nest in marshes, in low trees, on the ground in bulrushes or reeds, or on floating mats (Audubon, 2014f; TPWD, 2014h). They forage on invertebrates and fish by probing the sediment with their bill. During the spring nesting season, white-faced ibis congregate and form colonial nests within reeds, bulrushes, or other vegetation.

Suitable foraging and nesting habitat occurs in the vicinity of the Terminal Expansion site and the Pipeline Expansion route; however, no sightings occurred during field surveys and there are no known occurrences in the vicinity of the Project. Based on the lack of sightings in the Project area, the species mobility, the Project would not significantly affect the white-faced ibis.

#### **4.7.2.6 Wood Stork**

The wood stork is state listed in Texas as threatened but is not listed in Louisiana (BES 2013c, 2013d; LDWF, 2014). The wood stork breeds in Mexico and migrates to the Gulf states for foraging; there have been no breeding records in Texas since 1960 (Audubon, 2014g; FWS, 2014d). They prefer prairie ponds, flooded pastures, and other shallow water, including salt flats, for foraging.

Suitable foraging and nesting habitat occurs in the vicinity of the Terminal Expansion site and the Pipeline Expansion route; however, no sightings occurred during field surveys and there are no known occurrences in the Project area. Based on the lack of sightings, the abundance of suitable habitat in adjacent areas, and the species mobility, the Project would not significantly affect the wood stork.

#### **4.7.2.7 Rafinesque's Big-eared Bat**

Rafinesque's big-eared bat is state listed in Texas as threatened but is not listed in Louisiana (BES, 2013c, 2013d; LDWF, 2014). Rafinesque's big-eared bats are known to roost in cave entrances, in hollow trees, in man-made structures such as abandoned buildings, and under bridges in the forests of the southeastern United States (NSRL, 2014; TPWD, 2014i). The westernmost portion of their range extends

to the pine forests of East Texas (TPWD, 2014i). This species is sensitive to disturbance and avoids construction areas.

Suitable roosting habitat occurs in the vicinity of the Pipeline Expansion route; however, no sightings occurred during field surveys and there are no known occurrences in the Project area. Based on the lack of sightings, the species mobility, and the abundance of suitable habitat in adjacent areas, the Project would not significantly affect the Rafinesque's big-eared bat.

#### **4.7.2.8 Alligator Snapping Turtle**

The alligator snapping turtle is state listed in Texas as threatened and subject to restricted harvest in Louisiana (BES, 2013c, 2014d; LDWF, 2014). Alligator snapping turtles grow very large for turtles; they usually are found in slow moving rivers, lakes, or oxbows but also can be found in freshwater marsh areas with rivers close by (Herps of Texas, 2014b; NWF, 2014; FWS, 2014e). Suitable freshwater habitat is not found in the vicinity of the Project; however, they may traverse the SNWW to suitable upstream habitat in the Sabine River watershed.

Alligator snapping turtles are transient in the SNWW. Given the lack of suitable habitat in the Project area, the Project would not significantly affect the alligator snapping turtle.

#### **4.7.2.9 Texas Diamondback Terrapin**

The Texas diamondback terrapin is a Texas species of concern and subject to restricted harvest in Louisiana (LDWF, 2014; TPWD, 2013). They range from Louisiana to Corpus Christi Bay and live exclusively in brackish water, being the only turtle found in estuaries and saltwater marshes (TPWD, 2014j). Mating occurs in spring, and females nest in lightly vegetated, gently sloping shorelines above the high tide line.

Potential foraging and nesting habitat occurs in the vicinity of the Terminal Expansion; however, no sightings occurred during field surveys and there are no known occurrences in the Project area. Based on the lack of sightings during field surveys and the abundance of suitable habitat in adjacent areas, the Project would not significantly affect the Texas diamondback terrapin.

#### **4.7.2.10 Gulf Salt Marsh Snake**

The Gulf salt marsh snake is a Texas species of concern but is not listed in Louisiana (LDWF, 2014; TPWD, 2013). They prefer brackish and saltwater estuaries and marshes, and are found along the Gulf Coast (TPWD, 2014k). The Gulf salt marsh snake is nocturnal, hiding in shoreline debris and burrows in mud and sand. They mate in spring and birth live young in July and August; their forage includes fish, crustaceans, and other invertebrates (TPWD, 2014k).

Potential tidal marsh foraging and nesting habitat occurs in the vicinity of the Terminal Expansion; however, no sightings occurred during field surveys and there are no known occurrences in the Project area. Based on the lack of sightings in the Project area and the availability of suitable habitat in adjacent areas, the Project would not significantly affect the Gulf salt marsh snake.

#### **4.7.2.11 Timber/Canebrake Rattlesnake**

The timber/canebrake rattlesnake is state listed in Texas as threatened but is not listed in Louisiana (BES, 2013c, 2013d; LDWF, 2014). Timber/canebrake rattlesnake habitat includes upland pine and deciduous woodlands, riparian zones, moist bottomland forests, and swamps near permanent water sources (TPWD, 2014l). This species prefers areas with dense ground cover, such as grapevines or palmetto, and may seek refuge in tree stumps, logs, and branches (TPWD, 2014l).

Suitable foraging and nesting habitat is available in the vicinity of the Terminal Expansion and Pipeline Expansion route; however no sightings occurred during field surveys. Based on the lack of sightings and the abundance of suitable habitat in adjacent areas, the species may avoid the area during construction. Therefore, the Project would not significantly affect the timber/canebrake rattlesnake.

#### **4.7.3 Threatened and Endangered Species Conclusions**

The Project would have *no effect* on a total of 21 federally- and state-listed species, and is *not likely to adversely affect* the eight other federally-listed species (see table 4.7-1). The Project would not significantly affect the 12 additional state special-status species (state-listed as threatened or endangered or other special status) that could occur in the Project area (see table 4.7-2). Based on (1) the limited amount of available suitable foraging and nesting habitat in the area for federally listed, state-listed, and other special-status species; (2) the temporary nature of most impacts should they occur; (3) collocation with existing facilities and rights-of-way; and (4) the proposed mitigation measures, we conclude that the Project would not result in significant impacts on threatened, endangered, or other special-status species—or potential impacts would be adequately minimized by Golden Pass’ adherence to the FERC’s Plan and Procedures, the *Bird Strike Monitoring Plan*, and the SPCC Plan as well as the National Bald Eagle Management Guidelines (see section 4.6.1.3).

### **4.8 LAND USE, RECREATION, AND VISUAL RESOURCES**

#### **4.8.1 Land Use**

Golden Pass would construct the Project in Jefferson and Orange Counties, Texas, and in Calcasieu Parish, Louisiana. Land use in the vicinity of the Project generally is classified into the following categories: forested, planted pine, open land, open water, agricultural, residential, and industrial/commercial lands. Installation of facilities for the Terminal Expansion and Pipeline Expansion would require temporary disturbance of about 1,017.4 acres of land. After construction, operation of the Project would permanently affect about 838.4 acres. The remaining 178.9 acres would return to pre-construction conditions and uses. Table 4.8.1-1 summarizes the acreages of each land use type that would be affected during construction and operation of the Project.

TABLE 4.8.1-1																		
Land Uses Affected by the Golden Pass LNG Export Project <u>a</u>																		
County/ Parish, State	Forested <u>b</u>		Pine Plantation		Open Land <u>c</u>		Open Water		Agriculture <u>d</u>		Residential		Industrial/ Commercial		Existing ROW		Total	
	Cons <u>e</u>	Oper <u>f</u>	Cons	Oper	Cons	Oper	Cons	Oper	Cons	Oper	Cons	Oper	Cons	Oper	Cons	Oper	Cons	Oper
<b>Terminal Expansion</b>																		
Jefferson County, TX	63.4	59.1	0.0	0.0	420.3	410.8	183.7	70.5	0.0	0.0	0.0	0.0	244.6	235.8	0.0	0.0	912.1	776.2
Access Roads	0.0	0.0	0.0	0.0	2.0	2.0	0.0	0.0	0.0	0.0	0.0	0.0	4.6	4.6	0.0	0.0	6.6	6.6
<b>Terminal Expansion Subtotal</b>	<b>63.4</b>	<b>59.1</b>	<b>0.0</b>	<b>0.0</b>	<b>422.3</b>	<b>412.8</b>	<b>183.7</b>	<b>70.5</b>	<b>0.0</b>	<b>0.0</b>	<b>0.0</b>	<b>0.0</b>	<b>249.2</b>	<b>240.4</b>	<b>0.0</b>	<b>0.0</b>	<b>918.7</b>	<b>782.8</b>
<b>Pipeline Expansion</b>																		
Calcasieu Loop	2.0	0.4	0.2	0.2	2.7	1.3	0.0 <u>g</u>	0.0 <u>g</u>	9.8	4.6	0.0	0.0	0.4	0.3	6.9	4.5	22.0	11.2
ATWS	0.0	0.0	0.7	0.0	0.0 <u>g</u>	0.0	0.0	0.0	0.0	0.0	0.0	0.0	0.0	0.0	0.0	0.0	0.7	0.0
Access roads	0.0	0.0	0.0	0.0	0.1	0.1	0.0	0.0	0.0	0.0	0.0	0.0	0.0	0.0	0.0	0.0	0.1	0.1
<b>Pipe Storage and Contractor Yard</b>																		
Orange County, TX	0.0	0.0	0.0	0.0	0.0	0.0	0.0	0.0	0.0	0.0	0.0	0.0	13.0	0.0	0.0	0.0	13.0	0.0
<b>MP 1 Compressor Station</b>																		
Jefferson County, TX	0.8	0.8	0.0	0.0	7.4	7.4	0.0	0.0	0.0	0.0	0.0	0.0	1.4	1.4	0.0	0.0	9.6	9.6
ATWS	0.0	0.0	0.0	0.0	0.6	0.0	0.0	0.0	0.0	0.0	0.0	0.0	0.0	0.0	0.0	0.0	0.6	0.0
Access roads	0.0	0.0	0.0	0.0	0.1	0.1	0.0	0.0	0.0	0.0	0.0	0.0	0.0	0.0	0.0	0.0	0.1	0.1
<b>MP 33 Compressor Station</b>																		
Orange County, TX	6.8	6.8	0.0	0.0	0.3	0.3	0.0	0.0	0.0	0.0	0.0	0.0	0.0	0.0	0.0	0.0	7.0	7.0
ATWS	0.5	0.0	0.0	0.0	0.0	0.0	0.0	0.0	0.0	0.0	0.0	0.0	0.0	0.0	0.0	0.0	0.5	0.0
Access roads	1.7	1.7	0.0	0.0	0.0 <u>g</u>	0.0 <u>g</u>	0.0	0.0	0.0	0.0	0.0	0.0	0.0	0.0	0.3	0.3	2.0	2.0



TABLE 4.8.1-1 (continued)																			
Land Uses Affected by the Golden Pass LNG Export Project <u>a</u>																			
County/ Parish, State	Forested <u>b</u>		Pine Plantation		Open Land <u>c</u>		Open Water		Agriculture <u>d</u>		Residential		Industrial/ Commercial		Existing Right-of-Way		Total		
	Cons <u>e</u>	Oper <u>f</u>	Cons	Oper	Cons	Oper	Cons	Oper	Cons	Oper	Cons	Oper	Cons	Oper	Cons	Oper	Cons	Oper	
<b>MP 66 Compressor Station</b>																			
Calcasieu Parish, LA	0.0	0.0	14.7	14.7	0.1	0.1	0.0	0.0	0.0	0.0	0.0	0.0	0.0	0.0	0.0	0.0	0.0	14.8	14.8
ATWS	0.0	0.0	4.6	0.0	0.0	0.0	0.0	0.0	0.0	0.0	0.0	0.0	0.0	0.0	0.0	0.0	0.0	4.6	0.0
Access roads	0.0	0.0	1.9	1.9	0.0 <b>g</b>	0.0 <b>g</b>	0.0 <b>g</b>	0.0 <b>g</b>	0.0	0.0	0.0	0.0	2.1	2.1	0.0	0.0	4.0	4.0	
<b>NGPL Interconnection</b>																			
Jefferson County, TX	0.0	0.0	0.0	0.0	3.3	1.3	0.0	0.0	0.0	0.0	0.0	0.0	1.1	0.1	0.0	0.0	4.3	1.5	
ATWS	0.0	0.0	0.0	0.0	0.2	0.0	0.0	0.0	0.0	0.0	0.0	0.0	0.0	0.0	0.0	0.0	0.2	0.0	
<b>Texoma Interconnection</b>																			
Orange County, TX	0.0 <b>g</b>	0.0 <b>g</b>	0.0	0.0	0.1	0.0 <b>g</b>	0.0	0.0	0.0	0.0	0.0	0.0	3.0	0.4	0.6	0.5	3.6	0.9	
Access roads	0.0	0.0	0.0	0.0	0.0	0.0	0.0	0.0	0.0	0.0	0.0	0.0	0.1	0.1	0.2	0.2	0.3	0.3	
<b>Tennessee Gas Interconnection</b>																			
Calcasieu Parish, LA	0.0	0.0	0.0	0.0	0.0	0.0	0.0	0.0	0.0	0.0	0.0	0.0	1.1	1.1	0.0	0.0	1.1	1.1	
ATWS	0.0	0.0	0.0	0.0	0.3	0.0	0.0	0.0	0.0	0.0	0.0	0.0	2.9	0.0	0.0	0.0	3.1	0.0	
Access roads	0.0	0.0	0.0	0.0	0.0 <b>g</b>	0.0 <b>g</b>	0.0	0.0	0.0	0.0	0.0	0.0	2.0	2.0	0.0	0.0	2.0	2.0	
<b>TETCO Interconnection</b>																			
Calcasieu Parish, LA	0.0	0.0	0.1	0.1	0.1	0.1	0.0	0.0	0.0	0.0	0.0	0.0	0.9	0.1	0.0 <b>g</b>	0.0 <b>g</b>	1.1	0.2	
<b>Transco Interconnection</b>																			
Calcasieu Parish, LA	0.0	0.0	0.0 <b>g</b>	0.0 <b>g</b>	0.0	0.0	0.0	0.0	0.0	0.0	0.0	0.0	3.0	0.8	0.0	0.0	3.0	0.8	
ATWS	0.0	0.0	0.3	0.0	0.0 <b>g</b>	0.0	0.0	0.0	0.0	0.0	0.0	0.0	0.5	0.0	0.0	0.0	0.8	0.0	

TABLE 4.8.1-1 (continued)

Land Uses Affected by the Golden Pass LNG Export Project a

County/ Parish, State	Forested <u>b</u>		Pine Plantation		Open Land <u>c</u>		Open Water		Agriculture <u>d</u>		Residential		Industrial/ Commercial		Existing Right-of-Way		Total	
	Cons <u>e</u>	Oper <u>f</u>	Cons	Oper	Cons	Oper	Cons	Oper	Cons	Oper	Cons	Oper	Cons	Oper	Cons	Oper	Cons	Oper
Access roads	0.0	0.0	0.0	0.0	0.0 <u>g</u>	0.0 <u>g</u>	0.0	0.0	0.0	0.0	0.0	0.0	0.1	0.1	0.0	0.0	0.1	0.1
<b>Pipeline Expansion Subtotal</b>	<b>11.7</b>	<b>9.6</b>	<b>22.5</b>	<b>16.9</b>	<b>15.4</b>	<b>10.7</b>	<b>0.1</b>	<b>0.0 <u>g</u></b>	<b>9.8</b>	<b>4.6</b>	<b>0.0</b>	<b>0.0</b>	<b>31.3</b>	<b>8.4</b>	<b>8.0</b>	<b>5.5</b>	<b>98.7</b>	<b>55.6</b>
<b>TOTAL</b>	<b>75.1</b>	<b>68.7</b>	<b>22.5</b>	<b>16.9</b>	<b>437.7</b>	<b>423.5</b>	<b>183.8</b>	<b>70.6</b>	<b>9.8</b>	<b>4.6</b>	<b>0.0</b>	<b>0.0</b>	<b>280.5</b>	<b>248.7</b>	<b>8.0</b>	<b>5.5</b>	<b>1,017.4</b>	<b>838.4</b>

Notes:

a The numbers in this table have been rounded for presentation purposes. As a result, the totals may not reflect the sum of the addends.

b Forested acreages include upland forests and forested wetlands.

c Open land acreages include emergent and scrub-shrub wetlands.

d Agricultural wetlands (i.e., rice fields and PEMf) are reported in the agricultural lands category.

e Cons = impacts from construction

f Oper = portion of construction impacts that would be permanently maintained following construction

g Acreage of impacts was greater than zero but less than 0.05 acre and therefore was rounded to 0.0.

The definitions of each land use type are as follows:

- forested – includes upland and wetland forests;
- pine plantation – includes planted pine land used for silviculture;
- open land – includes non-forested open lands, such as existing utility rights-of-way, grassland/rangeland, emergent and scrub-shrub<sup>26</sup> wetlands and uplands, and grazing land;
- open water – includes water crossings greater than 100 feet;
- agricultural – includes active cropland or hay fields and rice fields (classified as PEMf in section 4.4);
- residential – includes residential yards, subdivisions, and planned new residential developments; and
- industrial/commercial – includes all other developed areas, such as roads, railroads, and industrial areas.

#### **4.8.1.1 Terminal Expansion**

The Terminal Expansion site would be on the west side of the SNWW, in Jefferson County, Texas. Land uses surrounding and within the expansion site are primarily industrial, forested uplands, forested and non-forested wetlands, open land, and open water. Golden Pass would construct the Terminal Expansion within and adjacent to the existing Golden Pass Import Terminal, which abuts the northern and western portions of the Terminal Expansion site. Construction of the Terminal Expansion facilities would require about 918.7 acres, including 422.3 acres of open land (which includes emergent and scrub-shrub wetlands), 63.4 acres of forested land, 249.2 acres of industrial land, and 183.7 acres of open water. About 724.7 acres of the 918.7 acres required for construction are within the existing terminal boundaries. Operation of the expanded terminal would require 782.8 of the 918.7 acres.

#### **Access Roads**

Table 4.8.1-2 lists the proposed access roads that would be used for construction and operation of the Project, including those associated with the Terminal Expansion. Golden Pass would use two existing private roads to access the Terminal Expansion site during construction. Some portions of these existing roads may require modifications such as grading, widening, and replacement of gravel. The primary access to the site is an existing paved road that provides access from the west. A portion of this road would be reconfigured to provide access to administrative and other support buildings. The reconfigured portion of the road would be paved. An existing gravel road would provide access to the site from the south. This road may require maintenance of drainage and/or replacement gravel. The existing access roads would require 6.6 acres of land and would be maintained for use during operation of the Terminal. Access roads and anticipated improvements are discussed in section 2.2.1.7.

---

<sup>26</sup> Scrub-shrub lands are dominated by woody vegetation less than 20 feet tall, such as sage brush, young trees, and small or stunted trees or shrubs.

<b>Access Road (MP Location)</b>	<b>County/Parish, State</b>	<b>Temporary/Permanent</b>	<b>Description</b>	<b>Predominate Land Use</b>	<b>Length (feet)</b>	<b>Acres</b>
0	Jefferson County, TX	Permanent	Existing, paved	Open land/industrial	6,925	6.6
1	Jefferson County, TX	Permanent	Existing, gravel	Open land	2,700	0.1
33	Orange County, TX	Permanent	New	Forested	1,270	2.3
63	Calcasieu Parish, LA	Permanent	Existing, paved	Industrial	4,150	2.0
65	Calcasieu Parish, LA	Temporary	New	Open land	230	0.1
66	Calcasieu Parish, LA	Permanent	Existing, gravel	Industrial/pine plantation	4,700	4.0
68.5	Calcasieu Parish, LA	Permanent	Existing, gravel	Industrial	200	0.1

#### **4.8.1.2 Pipeline Expansion**

##### **Pipeline**

During pipeline construction, Golden Pass typically would use a 100-foot-wide right-of-way in uplands (see figure 2.3.1). Golden Pass would require about 22.9 acres for construction of its pipeline (including ATWS and access roads). Of this amount, about 6.9 acres, or 30.1 percent, would be within existing rights-of-way. In these areas, the construction right-of-way would overlap the existing Golden Pass Pipeline right-of-way; with the width of the overlap dependent on the configuration of the existing right-of-way (see table 4.8.1-1).

During operation, Golden Pass would maintain an additional 25-foot-wide permanent easement adjacent to its existing 50-foot-wide permanent right-of-way. About 1 mile of the proposed pipeline would be installed using the HDD method, which would reduce ground disturbance along this portion of the right-of-way. In total, the operational right-of-way would permanently affect about 11.2 acres.

##### **Aboveground Facilities**

The Pipeline Expansion would include three new compressor stations, and modifications and upgrades at five existing interconnections. Golden Pass would construct the MP 1 Compressor Station adjacent to the existing terminal in Jefferson County, Texas. The new MP 1 Compressor Station would require about 10.2 acres (including ATWS) for construction, of which 9.6 acres would be used during operation of the compressor station.

The MP 33 Compressor Station would be in Orange County, Texas, and would adjacent to an existing pipeline corridor. The compressor station would require about 7.5 acres (including ATWS) for construction, of which 7.0 acres would be used during operation.

The MP 66 Compressor Station would be north of the existing TETCO facility and at the end of the Calcasieu Loop. The compressor station would require 19.3 acres for construction (including ATWS), of which 14.8 acres would be used during operation.

Golden Pass would make modifications at five existing interconnections: NGPL, Texoma, Tennessee Gas, TETCO, and Transco. The NGPL interconnection would require 4.6 acres during construction, of which 1.5 acres would be used during operation. The Texoma interconnection would require 3.6 acres of land during construction, of which 0.9 acre would be used during operation. The Tennessee Gas interconnection would require 4.2 acres during construction, of which 1.1 acres would be used during operation. The TETCO interconnection would require 1.1 acres during construction, of which 0.2 acre would be used during operation. The Transco interconnection would require 3.8 acres during construction, of which 0.8 acre would be used during operation. All construction acreages include land required for ATWS.

### **Pipe Storage and Contractor Yard**

The Pipeline Expansion would require temporary use of one pipe storage and contractor yard to store pipe and equipment for the Pipeline Expansion, and for contractor office space, on about 13.0 acres in Orange County, Texas (see figure 2.0-1). The proposed yard consists of industrial/commercial land. Use of this yard would result in temporary impacts and would be limited to the time of use for construction activities.

### **Additional Temporary Workspace/Staging Areas**

Golden Pass would need 10.6 acres of ATWS for construction of the pipeline and aboveground facilities. In the event that during construction of the Project Golden Pass requires new ATWS (e.g., in non-wetland areas to accommodate full right-of-way topsoil segregation or for truck turn-arounds where no reasonable alternative exists), these areas would typically fall within the previously surveyed area. Such requests would be reviewed using a variance request process.

### **Access Roads**

Golden Pass would use four existing private roads to access the pipeline right-of-way and aboveground facilities during construction (see table 4.8.1-2). Modifications would be required only for the access road at MP 66. This road would be widened from 10 to 20 feet, disturbing about 0.3 acre. Golden Pass would construct two new access roads. One access road would be a new 230-foot-long access road to the HDD staging area off Starks Big Woods Road, which would affect about 0.1 acre. The other new access road would provide access to the MP 33 Compressor Station. The new 1,270-foot access road would be off of Church House Road parallel to the existing right-of-way. Construction of this access road would affect 2.3 acres. All but one access road would be maintained for use during operation of the Project. Access roads and anticipated improvements are discussed in sections 2.2 and 2.3.

#### **4.8.1.3 Land Use Impacts and Mitigation**

Impacts and mitigation on forest and open land are described in sections 4.4 (wetlands) and 4.5 (vegetation) of this EIS. The sections below focus on land uses not discussed in detail elsewhere in the EIS.

## **Existing Golden Pass Import Terminal and Pipeline**

### Terminal Expansion

About 724.7 acres of the Terminal Expansion would be within the property boundaries of the existing Golden Pass Import Terminal.

### Pipeline Expansion

The entire pipeline right-of-way would be within or parallel and adjacent to the existing Golden Pass Pipeline right-of-way, limiting the amount of new land disturbance. This would result in impacts on 8.0 acres of land that are within an existing right-of-way.

### **Pine Plantation**

Golden Pass would not affect any pine plantation during construction of the Terminal Expansion. Golden Pass would clear about 22.5 acres of pine plantation during construction of the Pipeline Expansion. After construction, 5.6 acres within temporary workspaces would be available for planting and use in timber production. This would be a long-term impact due to the relatively long growth period required for marketable timber. Golden Pass would prohibit timber production within the permanent right-of-way, resulting in permanent removal of 16.9 acres of timber production. Golden Pass would compensate the landowners for the loss of timber production in accordance with the terms of individual easement negotiations.

### **Open Water**

#### Terminal Expansion

Open water is considered to be perennial waterbodies greater than 100 feet wide. Construction of the Terminal Expansion would affect about 183.7 acres of open water. This would include impacts from infrastructure, the Supply Dock, workspace, and the shoreline protection system. The majority of open water impacts, about 113.2 acres, would be associated with temporary workspace to support dredging activities for the Supply Dock (see section 4.3) and vessels required for installation of shoreline protection and dolphins (see section 4.1.4.2).

About 2.9 acres of open water would be filled for building and/or infrastructures, while 1.3 acres would be filled and used as part of the shoreline protection system.

As part of the Terminal Expansion, Golden Pass would construct and use a supply dock along the western bank of the SNWW. After construction, the Supply Dock would require routine maintenance dredging of about 25,000 yd<sup>3</sup> from a 13.2-acre area, resulting in a periodic impact on open water at the terminal. See section 4.3 for a discussion of dredging and associated impacts on water resources.

In addition, the existing Ship Slip at the terminal may be used to convey lighter soil material and equipment during construction. To facilitate these functions, eight temporary marine dolphins and six permanent marine dolphins would be installed in the existing Ship Slip. These would include six mooring dolphins and eight breasting dolphins. The temporary impacts associated with these activities would be 55.3 acres.

Open water adjacent to the Supply Dock would remain as open water, although public use would be prohibited. However, open water beyond the Terminal Expansion site would remain accessible for public use.

### Pipeline Expansion

No open water would be associated with the Pipeline Expansion, although smaller waterbodies would be crossed along the pipeline route.

### **Agricultural**

#### Terminal Expansion

The Terminal Expansion would not affect any agricultural lands during construction or operation.

#### Pipeline Expansion

Golden Pass would affect about 9.8 acres of agricultural lands (including cultivated rice fields) within the 100-foot-wide pipeline construction right-of-way, of which 2.3 acres are within the existing pipeline right-of-way. To minimize impacts on agricultural lands, Golden Pass would implement the measures required by FERC's Plan, including topsoil segregation, erosion control, and soil compaction mitigation. In addition, Golden Pass would request that landowners of the cultivated rice fields refrain from flooding the portions of their fields that are crossed by the pipeline prior to the start of construction to allow the fields to dry and construction to begin.

The pipeline and associated facilities, including ATWS, access roads, pipe storage and the contractor yard, would affect about 68.8 acres of lands with soils classified as prime farmland. Golden Pass would implement the measures contained in FERC's Plan, which includes mitigation measures to limit impacts, such as topsoil segregation and soil compaction mitigation in annually cultivated prime farmland.

After construction, Golden Pass would allow all cultivated agricultural land within the pipeline right-of-way to return to pre-construction land use. The Project would not permanently disturb any cultivated agricultural land. As a result, we conclude that the impact on agricultural land would be temporary to short term and would not be significant.

### **Residential Lands**

No residences or active businesses are located within 50 feet of the Project.

## **4.8.2 Landowner and Easement Requirements**

### **4.8.2.1 Terminal Expansion**

Of the 918.7 acres required for construction of the Terminal Expansion, 724.7 acres are under the ownership of Golden Pass and are within the existing Golden Pass Import Terminal property boundaries. The remaining 194.0 acres of land are privately owned. Golden Pass is currently in consultation with the appropriate agencies and landowners on acquisition of these lands.

### **4.8.2.2 Pipeline Expansion**

Golden Pass would install all facilities associated with the Pipeline Expansion on privately owned lands, totaling 98.7 acres. About 8.0 acres would be within the existing Golden Pass Pipeline right-of-way.

For privately owned land along the proposed pipeline route, Golden Pass would secure an easement to convey both temporary and permanent rights-of-way prior to construction. The easement acquisition process is designed to provide fair compensation to the landowners for the right of Golden Pass to use the property during construction and operation of the pipeline.

If an easement cannot be negotiated with a landowner and if the Project were Certificated by the FERC, Golden Pass could use the right to eminent domain granted to it under Section 7(h) of the NGA and the procedure set forth under the Federal Rules of Civil Procedure (Rule 71A) to obtain the right-of-way and ATWS areas. Golden Pass must compensate the landowner for the right-of-way and any damages incurred during construction. A court would determine the level of compensation. In either case (secured easement or eminent domain), Golden Pass would compensate the landowner for use of the land.

The pipeline route would cross one paved public road, one combination public road (i.e., part paved and part unpaved), and eight unpaved and/or private roads. Golden Pass would cross the paved public road, one of the agricultural roads, and an unpaved access road using the HDD crossing method to avoid impacts on the roadways and traffic. Golden Pass would cross all remaining roads using the open-cut method. Where open-cut construction is proposed on roads that provide access to private residences or businesses with no alternate entrance, Golden Pass would maintain passage during construction where possible. If a road closure is needed, Golden Pass would coordinate with landowners, as well as law enforcement and state/local highway departments regarding traffic control and detour signs. In addition, Golden Pass would attempt to avoid peak traffic times during construction of roadway crossings that could temporarily close roads, use signage to minimize impacts, and follow local regulations regarding maintaining the flow of traffic.

Golden Pass would keep roads free of mud from its construction equipment. Track-driven equipment would cross paved roads on tires or equipment pads to minimize damage to the road surface. To further minimize road damage, Golden Pass would enforce local weight limitations and restrictions. Golden Pass would repair any roadways damaged by its construction to pre-construction conditions. Use of these construction methods would not cause a significant impact on roadways.

### **4.8.3 Planned Developments**

#### **4.8.3.1 Terminal Expansion**

There are no existing or known planned developments within 0.25 mile of the Terminal Expansion site.

#### **4.8.3.2 Pipeline Expansion**

The proposed pipeline route would not cross and is not within 0.25 mile of any existing or known planned developments.

### **4.8.4 Recreation and Special Interest Areas**

#### **4.8.4.1 Terminal Expansion**

Golden Pass would construct the Terminal Expansion near several recreation areas, including Walter Umphrey State Park, J. D. Murphree WMA, Sabine Pass Battleground State Historical Park, and the Texas Point NWR. Potential visual impacts on these areas are discussed in section 4.8.6.

The Walter Umphrey State Park is across the SNWW on the southern tip of Pleasure Island, less than 0.5 mile from the Terminal Expansion site. The state park contains a public boat ramp, recreational vehicle (RV) park, and a lighted fishing pier. Users of the state park adjacent to the SNWW may notice an increase in barge traffic during construction; however, as stated in section 4.9.6, the expected peak daily traffic in the SNWW from deliveries to the Supply Dock is two to three vessels per day. Based on the number of expected deliveries, this increase in traffic is not expected to affect users of the state park or the waterways surrounding the park.



The J. D. Murphree WMA is a 24,498-acre area dominated by intermediate and brackish coastal marsh that is west of SH-87, less than 1 mile from the Terminal Expansion site. Activities that occur in the WMA include hunting, fishing, and wildlife viewing. The Project would not cross any portion of the WMA, nor would it hinder use of or access to the area. Therefore, the Project is not expected to adversely affect the WMA. Traffic impacts on SH-87 are discussed in section 4.9.6.

The Sabine Pass Battleground State Historic Park is about 5 miles south of the Terminal Expansion site. The park includes a monument, statue, interpretive pavilion, and boat ramp, and picnicking and fishing areas. The Texas Point NWR is about 5 miles south of the Terminal Expansion site. Activities that occur in the refuge include fishing, hunting, and wildlife observation. Based on the anticipated barge traffic associated with construction of the Project, no adverse impacts are expected on recreational fishing or boating. Access to the park and NWR from north of the Terminal Expansion site could be affected by traffic along SH-87; however, impacts would be temporary (see section 4.9.6).

Construction of the Terminal Expansion would require dredging in the waters of the SNWW adjacent to land and would increase barge and support vessel traffic in the waterway (also see section 4.9.7.1). During construction of the Terminal Expansion, barge traffic in the SNWW would increase. Golden Pass estimates that the peak daily traffic in the waterway associated with barge deliveries would be about two to three vessels per day. This increase in traffic related to construction of the Project would be short term. Although recreational boaters use the SNWW, the impacts on boat traffic during construction would be minor and short term.

Golden Pass does not anticipate an increase in approved LNG carrier traffic or a change in the size or quantity of ships that were previously analyzed in the EIS for the existing terminal (FERC, 2005). Therefore, there would not be a significant impact on recreational or commercial fishing in the vicinity of the Project.

#### **4.8.4.2 Pipeline Expansion**

No other state parks or special interest areas are near the proposed pipeline or associated aboveground facilities. However, hunting and fishing activities do occur in the vicinity of the pipeline facilities. During construction, hunting activities in the general area of the pipeline and aboveground facilities would be temporarily limited. Because this would be limited to the construction period, the impact would be short term.

Because the pipeline would be buried, we do not anticipate any impacts on local fishing, hunting, or other recreational activities during operation. Recreational access would be restricted on the compressor station sites.

#### **4.8.5 Visual Resources**

##### **4.8.5.1 Terminal Expansion**

The primary existing structures in the viewshed of the Terminal Expansion site include the existing Golden Pass Import Terminal, the Sabine Pass LNG Terminal, oil and gas production facilities, and storage tanks. The most prominent features in the existing viewshed at the Terminal Expansion site are five storage tanks at the Golden Pass Import Terminal that are 170 feet in height. The viewshed also includes the SNWW and Pleasure Island north of the Terminal Expansion site, and open land and wetlands to the east, west, and south.

The expanded terminal would include many aboveground structures that could result in a visual resource impact. These include three liquefaction trains, a supply dock, six marine dolphins, new buildings

and infrastructure, and one ground flare. Most of these structures would require lighting. In addition, each train would accommodate a main cryogenic heat exchanger, propane drum, amine regenerator drum, and acid gas removal unit absorber. These structures would range in height from 104 to 142 feet. Golden Pass would site a portion of the Terminal Expansion within the existing Golden Pass Import Terminal property boundaries and would construct the remaining portions adjacent to the existing terminal to the south and east. Table 4.8.5-1 lists the primary equipment and structures for the Terminal Expansion, along with their heights aboveground level.

<b>TABLE 4.8.5-1</b>			
<b>Major Equipment and Structures for the Terminal Expansion</b>			
<b>Structure</b>	<b>Number</b>	<b>Radius (feet)</b>	<b>Height (feet)</b>
Main cryogenic heat exchanger	3	7.58	142
Propane suction drum	3	5.50	104
Amine regenerator drum	3	5.00	116
Acid gas removal unit absorber	3	7.25	110

Based on a visual assessment conducted for the existing terminal, it was estimated that the structures of the existing terminal could be seen for distances of at least 5 miles because of the generally flat geography in the area of the terminal site (FERC, 2005). The primary visual receptors in the vicinity of the Terminal Expansion site would be residents on Pleasure Island, other residents in the area around the Project site, recreational users in and around the SNWW, and users of the Walter Umphrey State Park on Pleasure Island. In addition, recreational users of the Sabine Pass Battleground State Historical Park, and the Texas Point NWR may be able to view construction activities and barge traffic.

The viewshed of the Pleasure Island residents, as well as users of the Walter Umphrey State Park, currently includes the existing Golden Pass Import Terminal, the Sabine Pass LNG Terminal, and the SNWW. During construction of the Terminal Expansion, individuals within the viewshed would be able to see various construction activities, including construction equipment, personnel, and barge traffic. Given the industrial nature of the current viewshed and construction of the expanded terminal adjacent to the existing terminal, visual impacts during construction are expected to be minor and temporary. As discussed in section 4.9.7, increased barge traffic within the SNWW is expected to be minor; therefore, the additional barges associated with construction are not expected to affect users of the waterway or those in view of the waterway.

Operation of the expanded terminal would increase the overall developed footprint of the existing terminal site. However, given the existing industrialized nature of the area, including the Golden Pass Import Terminal and the nearby Sabine Pass LNG Terminal, we conclude that this change would not represent a significant impact on viewers in the Project area.

The existing terminal includes outdoor lighting that consists primarily of downlighting for safety and lights on tall structures for aircraft warnings. Golden Pass would use similar lighting on the expanded terminal during operation. Golden Pass states that the lighting design would focus lights only where needed and mitigate unwanted projection and upward throw of light. In addition, the use of shields, and the ability to turn off incandescent and LED lamps when unneeded, would aid in minimizing impacts on nearby receptors.

Visual receptors may be able to see the ground flare at night when in use; however, this would not occur regularly. The viewshed for the expanded terminal extends as far as 5.0 miles from the site. Most of

the viewers of night lights in that area would consist of residents of Pleasure Island, other residents at their homes, boaters in the waterway, and viewers from a variety of recreational locations in the viewshed. The lighting of the expanded terminal would appear similar to the existing terminal, although across an area about twice as large. Viewers familiar with the nighttime appearance of the existing terminal may notice a larger lit area. Although the lighting would be obvious throughout the viewshed and different in size than the currently lit area, it would be similar to the lighting of other LNG facilities in the area. We conclude that the impact of night lighting on visual resources would not be significant.

#### **4.8.5.2 Pipeline Expansion**

Clearing the right-of-way of vegetation would cause the primary impact on visual resources during construction and operation of the pipeline and associated facilities. To minimize visual impacts, the entire proposed right-of-way would parallel existing permanent rights-of-way, which would avoid development of a new corridor. This would limit the extent of changes in the viewshed. However, clearing of forested lands within the construction right-of-way and maintaining the permanent right-of-way as herbaceous and scrub-shrub vegetation types would change the viewscape for viewers in the area. We conclude that the impact would not be significant because the increase in width of the right-of-way would be difficult to discern, the amount of forested land affected would be limited to 2.0 acres, and there would be few observers of the change. Golden Pass would allow all other forested lands along the pipeline route to revert to pre-construction conditions; however, it could require 20 to 40 years to reach that stage, resulting in long-term visual impacts in those areas.

In addition to clearing vegetation, construction of the pipeline and associated facilities would require the presence of personnel, large construction equipment, and vehicles—all of which could be visible in areas accessible to the public, such as at roadways crossed by the route. There are no residences in the immediate vicinity of the construction right-of-way that would be affected by construction of the proposed pipeline. Only one paved, public road would be crossed by the pipeline, Starks Big Woods Road. The road would be crossed using the HDD method to avoid impacts on the highway and traffic. The land use in this area is open land, and the construction equipment and personnel would be visible to motorists on the highway in the vicinity of the right-of-way. These impacts would be temporary because of the brief period of potential observation by motorists. We conclude that, given the small change in viewscape, this temporary visual impact would not be significant.

In addition to the pipeline right-of-way, Golden Pass would construct three new compressor stations. The dominant features at each compressor station would be the compressor building, the control room, the utility building, a communication tower, and safety and security lighting. The compressor building would be the largest structure, with dimensions of 45 feet wide by 175 feet long and 35 feet tall. The tallest structure would be the communication tower, at 50 feet. The tower would not require any guy wires, markers, or lighting. At night, the lighting at the compressor stations would be the most visible component. However, Golden Pass has stated that it would design the lighting to avoid or minimize impacts on the viewscape.

The MP 1 Compressor Station would be constructed adjacent to the existing Golden Pass Import Terminal. The visual impacts due to construction and operation of the compressor station would be similar to those for the Terminal Expansion site. As stated above, the visual impacts from construction would be minor. Impacts from operation would not be significant given the current industrial setting of the area.

The MP 33 Compressor Station would be constructed adjacent to an existing pipeline corridor, and set back about 0.2 mile southeast of Church House Road. Construction of the compressor station would require clearing 8.9 acres of forested land. Motorists along Church House Road would be able to view the compressor station site, including construction activities and equipment; however, because the site would be set back from the road, these views would be limited. Although several residences are in the area, the

compressor station would likely not be visible from these homes because of the natural vegetation surrounding the properties. Overall, the visual impacts would not be significant given the location of the compressor station and the existing vegetation in the area.

The MP 66 Compressor Station would be constructed in a remote area with no homes, roads, or other public areas in view of the site. Given the limited access of the compressor station site, there would be no significant impacts on visual resources in the area.

#### **4.8.6 Coastal Zone Management Program**

The Terminal would be located within the Texas coastal zone, which is managed by the Texas RRC through the Texas CMP. The boundaries of the state's coastal zone include all or parts of 18 coastal counties, including Jefferson County. All activities or developments that affect Texas's coastal resources and require a federal permit or license are evaluated for compliance with the CZMA through the "federal consistency" process. Golden Pass submitted its application and request for consistency review to the Texas RRC on July 7, 2014. Golden Pass has requested a CZMA determination for the Project in conjunction with its review and comments to the COE as part of the COE Section 10/404 permitting process (see section 1.5). Golden Pass submitted a revised application for water quality certification and an application for determination of consistency with the Texas CMP on January 13, 2016.

As stated in its DMMP, Golden Pass is considering the use of one of two potential DMPAs for dredged material disposal. The DMPAs are managed either by the COE or SNND and would require authorizations from the SNND, the LDNR, and/or the LDEQ for placement of dredged materials at these locations. The Project would not affect any Wetland Reserve Program or Conservation Reserve Program lands.

The application is still undergoing review and a Section 10/404 permit has not been issued. As a result, Golden Pass has not received its consistency determination from the Texas RRC. A determination from the RRC that the Project is consistent with the Texas CMP must be received before we could issue a notice to proceed with constructing the Terminal Expansion or the Pipeline Expansion. Because Golden Pass has not yet obtained its authorization, **we recommend that:**

- **Prior to construction, Golden Pass should file documentation of concurrence from the Texas RRC that the Project is consistent with the Texas CMP.**

The FERC would not approve construction until all federal authorizations, including a consistency determination with the CZMA, have been granted.

## **4.9 SOCIOECONOMICS**

Socioeconomic conditions in the area may be affected by construction and operation of the Project. The Terminal Expansion portion of the Project would be in Jefferson County, Texas. The Pipeline Expansion portion of the Project would be in Jefferson and Orange Counties, Texas, and Calcasieu Parish, Louisiana. Construction and operation may affect population levels, employment levels, tax revenues, ongoing local expenditures by the operator, housing availability, demand for public services, or transportation in these areas. For the socioeconomic analysis, these two counties and one parish are considered the “Project area.”

### **4.9.1 Population**

Table 4.9.1-1 gives a summary of selected population and demographics information in the Project area.

#### **4.9.1.1 Terminal Expansion**

The population of Jefferson County was reported as 252,273 people in the 2010 census (U.S. Census Bureau, 2010). The population density was 287.9 people per square mile. The average population density for the state of Texas was 96.3 people per square mile.

Golden Pass estimates that the peak workforce for construction of the Terminal Expansion would be 2,900 workers and about 40 percent of the workforce would be hired locally, 40 percent would commute to the area weekly, and 20 percent would relocate to the area. Therefore, at the peak of construction, about 580 workers would relocate to the area for the length of their employment. If each of the workers that relocated from outside the Project area brought their families, and assuming an average household size in Jefferson County of 2.6 people (Index Mundi, 2014a), this would result in an increase of 1,508 people. In addition, 1,160 workers would commute into the area on a weekly basis. Workers commuting on a weekly basis would not be likely to relocate their families. The combination of workers relocating from outside the Project area with their families and workers commuting weekly would result in an overall increase of 2,668 people, a 1.1 percent increase in the Jefferson County population. This increase would represent a temporary and minor impact on the local population.

After construction, Golden Pass estimates that about 120 permanent jobs would be created at the terminal and an additional 70 would be created in office and support functions. This would be a small increase for the population of Jefferson County, and Golden Pass anticipates that many workers would be hired locally.

#### **4.9.1.2 Pipeline Expansion**

Pipeline Expansion work would occur in Jefferson<sup>27</sup> and Orange Counties, Texas, and Calcasieu Parish, Louisiana. The 2010 census reported a population of 81,837 in Orange County, with a population density of 245.3 people per square mile (U.S. Census Bureau, 2010). Calcasieu Parish had a population of 192,768 and a population density of 181.2 people per square mile. Collectively, these two counties and one parish represent a Project area of about 526,878 people.

---

<sup>27</sup> The population of Jefferson County, Texas, is described in section 4.9.1.1

TABLE 4.9.1-1								
Existing Socioeconomic Conditions in the Golden Pass LNG Export Project Area								
State/ County or Parish	Population		Population Density (per square mile)		Per Capita Income	Civilian Labor Force	Unemployment Rate (percent)	Top Two Major Industries <u>a</u>
	2000 <u>b</u>	2010 <u>c</u>	2000 <u>b</u>	2010 <u>c</u>	2008–2012 <u>d</u>	2008–2012 <u>d</u>	2012 <u>e</u>	2012 <u>d</u>
Texas	20,851,820	25,145,561	79.6	96.3	\$25,806	12,401,364	6.8	1. Retail Trade 2. Management, Business, and Science
Jefferson County	252,051	252,273	279.2	287.9	\$23,479	115,204	10.7	1. Manufacturing 2. Retail Trade
Orange County	84,966	81,837	254.7	245.3	\$24,362	37,686	9.8	1. Manufacturing 2. Retail Trade
Louisiana	4,468,958	4,533,372	102.6	104.9	\$24,264	2,123,336	6.4	1. Retail Trade 2. Entertainment <u>f</u>
Calcasieu Parish	183,577	192,768	171.4	181.2	\$24,255	95,953	5.9	1. Entertainment <u>f</u> 2. Retail Trade
<u>Notes:</u>								
<u>a</u> Excludes Education and Health Service industry								
<u>b</u> Source: U.S. Census Bureau, 2000								
<u>c</u> Source: U.S. Census Bureau, 2010								
<u>d</u> Source: U.S. Census Bureau, 2012								
<u>e</u> Source: U.S. Department of Labor, 2013								
<u>f</u> Entertainment refers to the Entertainment, Recreation, Accommodation and Food Services industry.								

### 4.9.1.3 Combined Terminal Expansion and Pipeline Expansion Impacts

The Terminal Expansion and Pipeline Expansion are expected to have their peak workforce requirements at roughly the same time. A combined workforce of 3,400 workers would be needed at the height of construction activities. This could represent a population increase of 3,128 people if each non-local worker moved with their family at an average household size of 2.6 people. This would be an increase to the Project area population of about 0.6 percent. Alternatively, since the majority of the work would occur in Jefferson County, the bulk of the construction workforce could opt to relocate to this county for the duration of construction. Golden Pass has estimated that 20 percent of the peak workforce would remain on the Project for the length of the construction activities and 30 percent of the workforce would remain on the Project for the duration of the peak years of construction, years 2 through 5. As this represents a longer term of employment, these workers may be more likely to relocate to the area. Based on location of the Project facilities and the anticipated make-up of the workforce over time, we estimate that about 2,748 people could relocate to Jefferson County. This would represent a 1.1 percent change in population in the county. These changes in the Project area population would be short term and minor.

Operation of the Project would require a permanent workforce of about 200 employees, which would represent a minor impact on the local population.

### 4.9.2 Economy and Employment

Table 4.9.2-1 shows employment and income information for the Project area. After the education and health service industry, retail trade employs the most people in both Texas and Louisiana. More specific to the Project area, manufacturing is the largest industry in both Jefferson County and Orange County, Texas; and the entertainment, accommodation, and food services industry is the largest industry in Calcasieu Parish, Louisiana (U.S. Census Bureau, 2012).

State / County or Parish	Texas	Jefferson County	Orange County	Louisiana	Calcasieu Parish
Major Industry 2008–2012 <u>a, b</u>	Retail Trade	Manufacturing	Manufacturing	Retail Trade	Entertainment, Accommodation and Food Services
2008–2012 Civilian Labor Force <u>a</u>	12,401,364	115,204	37,686	2,175,983	92,742
2008–2012 Per Capita Income (dollars) <u>a</u>	25,806	23,479	24,362	24,264	24,255
2008–2012 Population below poverty level (percent) <u>a</u>	17.4	19.3	14.8	18.7	16.8
2012 Annual Unemployment Rate (percent) <u>c</u>	6.8	10.7	9.8	6.4	5.9
<b>Notes:</b>					
<u>a</u>	Source: U.S. Census Bureau, 2012				
<u>b</u>	Excludes Education and Health Service industry				
<u>c</u>	Source: U.S. Department of Labor, 2013				

#### **4.9.2.1 Terminal Expansion**

The “civilian labor force” is defined as the total of employed persons and those searching for work. In Jefferson County, the total civilian labor force is 115,204 people, and the per capita income is \$23,479 (U.S. Census Bureau, 2012). The per capita income is lower than the overall average for Texas, which is \$25,806. The unemployment rate is 10.7 percent, and 19.3 percent of the population is below the poverty level (U.S. Census Bureau, 2012). These are both higher than the Texas state averages of 6.8 percent unemployment and 17.4 percent poverty rate (U.S. Department of Labor, 2013).

Construction jobs from the Project would add temporary employment opportunities in the area. Golden Pass estimates that about 40 percent of the workforce would be hired locally, resulting in the employment of 1,160 local workers at the peak of construction. Another 40 percent of the workforce would be hired from within 100 miles of the Terminal Expansion site. This would result in a minor, temporary decrease in the unemployment rate for the Project area. Golden Pass estimates a total payroll of \$1.055 billion during construction of the Terminal Expansion. Additional economic benefits would be expected, as workers would spend a portion of their income at local businesses. Golden Pass estimates that their direct local expenditures on goods, equipment, and services would total \$2.67 billion. Overall, this would result in a beneficial, but temporary, increase in the local economy.

During operation of the expanded terminal, Golden Pass estimates that it would need 120 permanent new positions at the terminal and 70 more office and support positions. These added jobs would add more employment opportunities and, as the workers spend their salaries in the community, the local economy and employment in the Project area would experience permanent minor economic benefits.

#### **4.9.2.2 Pipeline Expansion**

The civilian labor force in Orange County, Texas, is 37,686 people, and in Calcasieu Parish, Louisiana, is 92,742 people. The per capita income in Orange County and Calcasieu Parish is \$24,362 and \$24,255, respectively (U.S. Census Bureau, 2012). Both of these amounts are below the per capita incomes for their respective states of Texas (\$25,806) and Louisiana (\$24,264). The unemployment rate in Orange County is 9.8 percent, which is higher than the 6.8 percent unemployment rate for Texas as a whole (U.S. Department of Labor, 2013). The unemployment rate in Calcasieu Parish of 5.9 percent is lower than the unemployment rate for Louisiana, which is 6.4 percent (U.S. Department of Labor, 2013). Economic statistics for Jefferson County are reported in section 4.1.2.1.

During construction of the Pipeline Expansion, temporary benefits to the local economy would result from the increase in jobs and the purchase of goods and services in the Project area by workers. The projected payroll for the Pipeline Expansion construction is \$40 million. Total direct local expenditures in the Project area for the Pipeline Expansion are expected to be \$100 million. Construction of the Project would result in a temporary beneficial economic impact on the Project area.

Operation of the Pipeline Expansion would require about 10 new employees, which would result in minor, permanent beneficial impacts on the local economy and employment.

### **4.9.3 Local Taxes and Government Revenue**

#### **4.9.3.1 Terminal Expansion**

Golden Pass estimates that it would spend \$2.67 billion on direct local expenditures during construction of the Terminal Expansion. This would generate increased federal, state, and local tax revenue in Jefferson County, Texas. The estimated \$1.055 billion in payroll would increase the federal government’s income tax revenues.



If all \$2.67 billion of direct local expenditures were subject to the Texas sales tax rate of 6.25 percent, over \$160 million in state sales tax revenues would result. In addition, city and local governments can tax up to 2 percent on top of the state amount. If the \$2.67 billion of expenditures were subject to these additional taxes, it would amount to more than \$50 million in local tax revenues over the course of construction (Tax-Rates.org, 2014). The federal income tax revenue on the \$1.055 billion in payroll would be around \$150 million to \$200 million. There is no state income tax in Texas.

The total investment in the Terminal Expansion over 5 years of construction is estimated to be \$10 billion. In addition to the direct federal, state, and local taxes associated with this investment, significant indirect effects on the economy would be expected. Indirect impacts include the effects of expenditures by construction workers and other employees on goods and services, and expenditures by suppliers or vendors as a result of increased demand caused by construction. The total direct and indirect impacts of the Terminal Expansion were estimated in a report by the Perryman Group (Perryman Group, 2012).

The total estimated direct and indirect tax benefits over the 5 years of construction of the Terminal Expansion in Jefferson County, Texas, would be \$106 million (Perryman Group, 2012). The federal tax benefits are estimated to be \$1.726 billion, and the state of Texas would be expected to gain \$707.9 million in tax benefits (Perryman Group, 2012). This increased tax benefit for the federal, state, and local governments would be a beneficial temporary economic impact, limited to the period of construction.

The 2013 real estate property taxes on the existing Golden Pass Import Terminal were about \$5.6 million and would be expected to be similar during operation of the Terminal Expansion. During operation of the Project, total direct and indirect tax benefits are expected to total \$6.5 million for Jefferson County, \$18.1 million for the state of Texas, and \$25.9 million for the federal government over the life of the Project (Perryman Group, 2012). This would result in a permanent beneficial impact on federal, state, and local tax revenues.

#### **4.9.3.2 Pipeline Expansion**

The estimated direct local expenditures for construction of the Pipeline Expansion would be \$100 million. These expenditures would temporarily increase tax revenues in the Project area. The 2013 real estate property taxes on the existing Golden Pass Pipeline were about \$2.6 million and would be expected to be similar during operation of the Pipeline Expansion. Operation of the Pipeline Expansion would result in a small permanent impact on tax revenues because additional required maintenance and staffing expenditures would in turn generate tax revenue. This would result in a permanent beneficial impact on federal, state, and local tax revenues.

#### 4.9.4 Housing

Table 4.9.4-1 provides housing data for the Project area.

<b>TABLE 4.9.4-1</b>						
<b>Housing Characteristics of the Golden Pass LNG Export Project Area</b>						
<b>State/ County or Parish</b>	<b>Vacant Housing Units <u>a</u>, <u>b</u></b>	<b>Vacant Housing Units for Rent <u>b</u></b>	<b>Rental Vacancy Rate (percent) <u>a</u></b>	<b>For Seasonal, Recreational, or Occasional Use <u>a</u>, <u>b</u></b>	<b>Hotels/ Motels <u>c</u></b>	<b>Number of Campgrounds and RV Parks <u>d</u></b>
<b>Texas</b>	<b>1,195,539</b>	<b>394,310</b>	<b>9.6</b>	<b>235,280</b>	<b>8,625</b>	<b>2,652</b>
Jefferson County	11,869	4,380	8.2	907	96	26
Orange County	4,243	1,567	13.1	346	30	15
<b>Louisiana</b>	<b>267,830</b>	<b>66,857</b>	<b>8.4</b>	<b>51,271</b>	<b>1,875</b>	<b>342</b>
Calcasieu Parish	9,628	3,015	9.7	1,178	85	27
Housing Definitions (US Census Bureau, 2010)						
Vacant Housing Unit – A housing unit is vacant if no one is living in it at the time of enumeration.						
For Seasonal, Recreational, or Occasional Use – Vacant units used or intended for use only in certain seasons or for weekends or other occasional use throughout the year.						
<u>Notes:</u>						
<u>a</u>	Source: U.S. Census Bureau, 2012					
<u>b</u>	Source: U.S. Census Bureau, 2010					
<u>c</u>	Source: HotelsMotels, 2014					
<u>d</u>	Source: Yellow Pages for Business, 2014					

##### 4.9.4.1 Terminal Expansion

According to the U.S. Census Bureau, there are 11,869 vacant housing units in Jefferson County, Texas, 4,380 of which are available for rent; and the rental vacancy rate is 8.2 percent (U.S. Census Bureau, 2012). There are also 96 hotels and motels, and 26 campgrounds and RV parks. At the height of construction activities, a peak workforce of about 2,900 workers would be required for the Terminal Expansion. Assuming that the entire workforce was non-local, the combination of vacant rental units and hotel/motel rooms would accommodate the required workforce. In addition, a portion of the workforce is expected to be hired locally.

Operation of the terminal after expansion would require about 120 new positions at the terminal and 70 new positions in office and support functions. These permanent staff would have a minor impact on the local housing market.

##### 4.9.4.2 Pipeline Expansion

The peak workforce that would be required during the Pipeline Expansion is estimated to be 500 workers. In addition to the housing in Jefferson County described in section 4.9.4.1, Orange County, Texas, has 4,243 vacant housing units and Calcasieu Parish has 9,628. Orange County has a rental vacancy rate of 13.1 percent and 1,567 vacant housing units for rent, and Calcasieu Parish, Louisiana, has a rental vacancy rate of 9.7 percent and 3,015 vacant housing units for rent. In addition to the housing described

for Jefferson County, 115 more hotels/motels and 42 more campgrounds and RV parks are in the Project area. The available housing units for rent and the other housing options in the Project area would be expected to accommodate the construction workforce for the Pipeline Expansion.

Operation of the Pipeline Expansion after construction would require about 10 employees, which would represent a negligible impact on the local housing market.

#### 4.9.4.3 Combined Terminal Expansion and Pipeline Expansion Impacts

The peak workforce requirements for the Terminal Expansion and the Pipeline Expansion would take place at roughly the same time. This would create an overall workforce of about 3,400 during the height of construction activities. However, Golden Pass estimates that about 40 percent of the workforce would be hired locally and these workers would not require additional housing. The total available housing units for rent in the Project area is 8,962, the total number of hotels or motels is 211, and the total number of campgrounds or RV parks is 68. The vast majority of the work would be in Jefferson County, Texas, which also has the most available housing.

We anticipate that the available housing in the Project area would be able to accommodate the entire non-local peak workforce. Impacts on housing during construction therefore are anticipated to be temporary and minor.

Operation of the Project would require about 200 permanent employees. If all of these employees relocated from outside the Project area, the impact on housing would not be significant.

#### 4.9.5 Public Services

Public services in the Project area are summarized in table 4.9.5-1.

TABLE 4.9.5-1							
Public Service Data for the Golden Pass LNG Export Project Area							
State	County / Parish	Education		Public Safety		Healthcare	
		Number of Public Schools <b>a</b>	Total Enrollment 2012–2013 <b>a</b>	Number of Police Departments <b>b</b>	Number of Fire Departments <b>c</b>	Number of Hospitals	Number of Hospital Beds
Texas	Jefferson County	77	42,188	7	5	9 <sup>d</sup>	1,612 <b>d</b>
	Orange County	25	15,557	8	3	1 <sup>d</sup>	112 <b>d</b>
Louisiana	Calcasieu Parish	60	33,017	8	5	5 <sup>e</sup>	631 <b>e</b>
<b>a</b>	Source: National Center for Education Statistics, 2014						
<b>b</b>	Source: USA Cops, 2014						
<b>c</b>	Source: USA Fire and Rescue, 2014						
<b>d</b>	Source: Texas Department of State Health Services, 2012						
<b>e</b>	Source: American Hospital Directory, 2012						

#### **4.9.5.1 Terminal Expansion**

Jefferson County, Texas, has 77 public schools with a total enrollment of 42,188 students. The county has seven police departments, five fire departments, and nine hospitals with a total of 1,612 beds.

If all of the 2,900 workers expected during the peak of construction relocated to the Project area and had an average of two school-aged children, there would be an increase of 5,800 students in Jefferson County. This would represent a 13.7 percent increase in enrollment. However, Golden Pass estimates that about 40 percent of the workforce would be hired locally and another 40 percent would commute into the area weekly, and would not need to relocate their families. If the remaining 20 percent of the workforce relocated with an average of two school-aged children, there would be an increase of about 1,160 students. This would be a temporary 2.7 percent increase in the total enrollment. Because these children would be spread out between several schools and across grade levels, the increase is not expected to significantly affect local schools.

Other local public services currently serve the entire population of Jefferson County and, as discussed in section 4.9.1.1, the Terminal Expansion would result in a temporary impact on the population in the Project area. Golden Pass states that they would continue to coordinate with local municipalities in proximity to the Terminal Expansion to ensure that emergency response plans are integrated with existing service providers.

Golden Pass anticipates hiring local individuals to fill the 120 permanent terminal positions and the 70 permanent office and support positions associated with operation of the Project; therefore, impacts on local public services are not expected. However, if all the positions are filled from outside the Project area, the impact on public services would last for the life of the Project.

#### **4.9.5.2 Pipeline Expansion**

Orange County, Texas, has 25 public schools with a total enrollment of 15,557 students. Calcasieu Parish, Louisiana has 60 public schools with a total enrollment of 33,017 students. With the addition of Jefferson County, as described in section 4.9.5.1, there are 162 public schools with a total enrollment of 90,762 students located in the Project area. The temporary increase in population due to the Pipeline Expansion's peak workforce of 500 workers could lead to an increase of 1,000 students if each worker relocated to the area with two school-aged children. This would represent a 0.6 percent increase in enrollment in Project area schools during the period of construction.

Similarly, the increased population is not expected to significantly affect the other public services in the area. Orange County has eight police departments, three fire departments, and one hospital with 112 beds. Calcasieu Parish, Louisiana, has eight police departments, five fire departments, and five hospitals with 631 beds. Including Jefferson County, as described in section 4.9.5.1, there are 23 police departments, 13 fire departments, and 15 hospitals with a total of 2,355 beds located in the Project area.

Operation of the Pipeline Expansion is not expected to affect public services in the Project area because only a few changes to the existing pipeline functions and a small increase in the workforce of about 10 employees would be associated with operation. Golden Pass would coordinate with local municipalities in proximity to the Pipeline Expansion to ensure that emergency response plans are integrated with existing local service providers.

## **4.9.6 Transportation**

### **4.9.6.1 Terminal Expansion**

Highway access to the Terminal Expansion construction area would be provided via SH-87. Traffic levels could increase from construction worker vehicle trips and freight deliveries to the site. These types of trips generally would occur at different times of the day, helping to minimize the cumulative impact. The terminal site has two entrances that would be used during the Terminal Expansion, and the Texas Department of Transportation previously constructed left turn lanes on SH-87 at each of the entrances to help maintain traffic flow.

To help minimize the construction worker vehicle trips to the site, Golden Pass would establish satellite parking locations, and a shuttle service would transport workers to the Terminal Expansion construction area. Golden Pass would coordinate the traffic flows in and out of these satellite locations with the Jefferson County Sherriff Department and the City of Port Arthur in order to help minimize congestion and ensure public safety.

Ground-based freight deliveries via truck would start at about two deliveries per day at the beginning of the Project construction, increasing to 20 trucks per day in year 3, and gradually decreasing to two deliveries per day by the end of construction. Construction materials delivered to the Terminal Expansion would be required to comply with local weight guidelines for SH-87 and area bridges, in coordination with the Texas Department of Transportation. Heavy and oversized loads would be transported by barge to the Terminal Expansion site using the Supply Dock. The use of the Supply Dock would help reduce freight traffic on the highways, and it would reduce the potential damage to roadways from heavy loads. Given the use of satellite parking areas and the Supply Dock, the Project is not expected to significantly affect traffic along SH-87.

Operation of the expanded Terminal would increase freight and worker traffic but not to the extent of the construction traffic. During operation, trucks would deliver refrigerant for use in the liquefaction process and trucks would haul away condensate product. Golden Pass estimates the potential transits to and from the expanded Terminal would be 15 per day. This change in traffic flow and use of the local roads would last for the life of the Project.

### **Marine Traffic Impacts**

Golden Pass would construct a supply dock to support the transfer of construction materials delivered by barge. Marine traffic would access the Supply Dock along the SNWW. The SNWW supports the fourth largest amount of total tonnage of any waterway in the nation. Between 2009 and 2013, an average of 141 million short tons was shipped on the SNWW per year (COE, 2013).

The Supply Dock would be constructed in a way to prevent obstructing ship traffic in the channel. During construction, Golden Pass estimates that two deliveries would be needed per day with a potential maximum of three deliveries in 1 day. These trips would not cause a significant impact when compared to the total amount of traffic in the SNWW.

In addition to the commercial barge traffic on the SNWW, traffic is associated with commercial fishing that occurs offshore. Commercial fishing traffic is expected to be minor. Recreational fishing also occurs in the area of the Terminal Expansion along the SNWW. The Saltwater Angler's League of Texas Memorial Day Fishing Classic occurs annually in Sabine Pass. Golden Pass has agreed to coordinate with the Coast Guard and others to ensure that any impacts caused by Terminal Expansion construction and operation would be minimized.

During operation of the expanded Terminal, ships would use existing marine berths at the existing terminal. The existing terminal is currently approved for about 200 transits per year under a Coast Guard WSA, and the proposed Terminal Expansion would operate under this approval.

#### **4.9.6.2 Pipeline Expansion**

The Pipeline Expansion would include about 2.6 miles of new pipeline. The only paved road that would be crossed by the proposed pipeline would be Starks Big Woods Road. Golden Pass would cross this road using HDD, which would minimize any traffic interruptions. Other roads that would be crossed include small private farm roads that appear to have very low traffic flows. Golden Pass would coordinate with local law enforcement and keep at least one lane open for all public road crossings. For private road crossings, Golden Pass would coordinate with individual landowners to limit disturbances only to what is necessary and to ensure emergency access at all times.

The estimated construction workforce for the Pipeline Expansion would peak at 500 workers. The traffic created by the peak workforce would be somewhat dispersed over the Project area, and the maximum peak workforce at any one Project component would be 150 workers. The average workforce for each location would be about 45 to 50 workers during construction. This number of workers is not expected to significantly affect traffic flows in the Project area.

Operation of the Pipeline Expansion would not cause significant impacts on local transportation.

#### **4.9.7 Environmental Justice**

Executive Order 12898 on Environmental Justice requires federal agencies to identify and address any instances where their actions may create disproportionately high and adverse health or environmental effects on minority or low-income populations. Consistent with EO 12898, the CEQ called on federal agencies to actively scrutinize the following issues with respect to environmental justice (CEQ, 1997a):

- the racial and economic composition of affected communities;
- health-related issues that may amplify project effects on minority or low-income individuals; and
- public participation strategies, including community or tribal participation in the process.

The EPA's Environmental Justice Policies focus on enhancing opportunities for residents to participate in decision making. The EPA (2011a) states that Environmental Justice involves meaningful involvement so that: "(1) potentially affected community residents have an appropriate opportunity to participate in decisions about a proposed activity that will affect their environment and/or health; (2) the public's contributions can influence the regulatory agency's decision; (3) the concerns of all participants involved will be considered in the decision-making process; and (4) the decision-makers seek out and facilitate the involvement of those potentially affected."

As discussed in section 1.3, there have been many opportunities for the public to comment on and provide input about the Project. Golden Pass met with many different stakeholders during initial development of the Project, including local residents and affected landowners. Golden Pass held a number of open houses in the Project area for the affected communities and local authorities. Golden Pass also established, and maintains, a website (<http://goldenpassproducts.com/>) to share information about the Project with the public.

Golden Pass used the FERC's pre-filing process (see section 1.3). One of the major goals of this process is to increase public awareness and encourage public input regarding every aspect of the Project

before an application is filed. As part of this process, the FERC staff participated in all of Golden Pass’ open houses to receive input from the public about the Project. Interested parties have had, and would continue to be given, opportunities to participate in the NEPA review process. To date, this included the opportunity to participate in the FERC’s public scoping meetings in the Project area to identify concerns and issues that should be covered in the EIS, and to submit written comments about the Project to the FERC. Following completion of the draft EIS, the public will have an opportunity to comment on the document electronically, in writing, or in person at meetings to be held in the Project area to receive comments on the draft EIS. All comments on the draft EIS will be responded to in the Final EIS.

Guidance from the CEQ states that “minority populations should be identified where either: (a) the minority population of the affected area exceeds 50 percent or (b) the minority population percentage of the affected area is meaningfully greater than the minority population percentage in the general population or other appropriate unit of geographic analysis” (CEQ, 1997a). “Minority populations,” defined as Hispanics, Asian-Americans and Pacific Islanders, African-Americans, and American Indians and Alaskan Natives persons, represent more than 20 percent of the population in each of the counties or parishes that would be traversed by the Project (see table 4.9.7-1). However, the proportion of individual minority populations is less than respective state-level statistics in the counties and parish that make up the Project area for the Project (see table 4.9.7-1). To further assess whether the minority population in the Project area is substantially greater than the minority population in surrounding areas, we compared census tract-level demographics to the respective county or parish proportion. Each of the census tracts within 0.5 mile of the Project has significantly lower minority populations than the respective county- or parish-level statistic (see table 4.9.7-1). These statistics indicate that a disproportionate effect on minority populations is unlikely, according to the guidance set forth by the CEQ.

<b>TABLE 4.9.7-1</b>		
<b>Low-Income and Minority Populations in the Golden Pass LNG Export Project Area</b>		
<b>State/ County or Parish</b>	<b>Population below Poverty Level (percent)</b>	<b>Non-white Population (percent)</b>
	<b>2009–2013 <u>a</u></b>	<b>2010 <u>b</u></b>
<b>Texas</b>	<b>17.6</b>	<b>54.7</b>
Jefferson County	21.0	46.3
Census Tract 116	14.0	17.2
Orange County	14.4	12.2
Census Tract 222	13.0	9.9
<b>Louisiana</b>	<b>19.1</b>	<b>39.7</b>
Calcasieu Parish	17.4	25.5
Census Tract 36	21.0	6.5
Cameron Parish	8.7	2.0
Census Tract 9702.01	6.0	3.3
<b>Notes:</b>		
<b><u>a</u></b>	Source: U.S. Census Bureau, 2013	
<b><u>b</u></b>	Source: U.S. Census Bureau, 2010	

The U.S. Census Bureau defines “low-income populations” as those living below the established poverty level. The U.S. Census Bureau also reports the percentage of county (or parish) populations with an income below the poverty level, which is presented in table 4.9.7-1. To evaluate the potential for a low-income population to be affected disproportionately, we first compared the poverty level rates for the counties and parish within the Project area to those of their respective state levels.

The poverty rates in Jefferson County in Texas and Calcasieu Parish in Louisiana are similar to or lower than the respective state-wide levels, but Orange County in Texas has poverty a rate that is slightly higher than the state level. To further assess whether the poverty levels in the Project area are substantially greater than the poverty levels in surrounding areas, we compared census tract-level demographics to the respective county or parish level. All but one census tract within 0.5 mile of the Project has poverty rates that are similar to or lower than the respective county or parish level. The poverty rate in Census Tract 36 in Calcasieu Parish is higher than the poverty rate for the parish and the state. While these statistics are indicative of a potentially disproportionate effect on low-income communities, the poverty rate at the specific census tract level is only slightly higher than the respective parish and state levels.

As described above, the Project would result in negligible to minor negative impacts and minor positive impacts on socioeconomic characteristics and economies in the Project area. As discussed throughout this EIS, potentially adverse environmental effects associated with the Project would be minimized or mitigated, as applicable. Although the racial and economic composition of the counties and parish traversed by the Project and census tracts within 0.5 mile of the Project show some deviations from state-level statistics, there is no evidence that the Project would cause a disproportionate share of adverse environmental or socioeconomic impacts on any racial, ethnic, or socioeconomic group.

The primary Project-related health issue would be the risk associated with an unanticipated terminal, LNG carrier, pipeline, or compressor station failure. Section 4.12 discusses the localized risks to public safety that could result from a terminal, LNG carrier, or pipeline failure and describes how applicable safety regulations and standards would minimize the potential for these risks. Because the Project generally would traverse sparsely populated areas, the number of persons who would be at risk of injury due to a failure would be low; and there is no evidence that such risk would be disproportionately borne by any racial, ethnic, or socioeconomic group.

Construction of the Project would result in minor beneficial impacts from increases in payroll taxes, purchases made by the workforce, and expenses associated with the acquisition of material goods and equipment. Operation of the Project would result in a minor to moderate beneficial effect on the counties, parish, and local communities from the increase in property taxes that would be collected.

#### **4.10 CULTURAL RESOURCES**

Section 106 of the NHPA, as amended, requires the FERC to take into account the effect of its undertakings on properties listed, or eligible for listing, in the NRHP and to afford the ACHP an opportunity to comment on the undertaking. Golden Pass, a non-federal party, are assisting the FERC in meeting our obligations under Section 106 and the implementing regulations in 36 CFR 800 by preparing the necessary information, analyses, and recommendations, as authorized by 36 CFR 800.2(a)(3).

Golden Pass consulted with the Louisiana and Texas State Historic Preservation Officers (SHPO) to define the cultural resources survey area for the Project. As required under Section 106, the FERC has defined the Project’s Area of Potential Effect (APE) as the Project area whereby direct effects could result from ground-disturbing activities and indirect effects could result from visual, auditory, or atmospheric changes. Direct effects are typically long term and adverse while indirect effects may be temporary or short term. The direct APE is 1,017 acres and includes the Terminal Expansion site, pipeline construction workspace, ATWS, access roads, pipe storage and contractor yard, compressor stations, and ancillary



pipeline facilities. The indirect APE includes those areas within 1 mile of these proposed Project facilities and within 0.5 mile of the Calcasieu Loop.

Construction and operation of the Project could affect historic properties (i.e., cultural resources listed, or eligible for listing, in the NRHP). Historic properties include prehistoric or historic archaeological sites, districts, buildings, structures, and objects, as well as locations with traditional value to Native Americans or other groups. Such historic properties generally must possess integrity of location, design, setting, materials, workmanship, feeling, and association, and must meet one or more of the criteria specified in 36 CFR 60.4. The FERC consulted with the SHPOs and federally recognized Indian tribes (tribes) regarding determinations of eligibility to the NRHP and Project effects to historic properties located in the APE.

#### **4.10.1 Consultation**

On September 19, 2013, the FERC sent copies of the NOI for the Project to a wide range of stakeholders, including the ACHP, the Bureau of Indian Affairs, the Texas and Louisiana SHPOs, and tribes that may have an interest in the Project area. The NOI contained a paragraph about Section 106 of the NHPA and stated that the notice is used to initiate consultations with the SHPO, and to solicit their views and those of other government agencies, interested tribes, and the public on the Project's potential effects on historic properties.

In addition to the FERC's notification process, Golden Pass or its contractor, HRA Gray & Pape, LLC (HRA) separately contacted the SHPOs and tribes that might attach cultural or religious significance to cultural resources in the Project area.

##### **4.10.1.1 State Historic Preservation Officers**

Table 4.10.1-1 summarizes communications with the SHPOs for the Project. In addition to what is presented in table 4.10.1-1, previous consultation also occurred during permitting of the existing Golden Pass Import Terminal, which was summarized in the FERC final EIS (FERC, 2005).

HRA submitted a letter report to the Louisiana and Texas SHPOs on August 6, 2013, containing the results of cultural resources site file searches within 1 mile of the APE and recommendations that fieldwork was not required for the MP 1 Compressor Station, Supply Dock, and Calcasieu Loop and access road. The Texas SHPO concurred with this recommendation on August 27, 2013. The Louisiana SHPO concurred with this recommendation on December 11, 2013.

HRA submitted a letter report to the Louisiana and Texas SHPOs on February 25, 2014, detailing the results of pedestrian surveys at compressor stations within the APE and recommendations that there would be no Project effects. On March 14, 2014, the Texas SHPO concurred that no historic properties would be affected by these facilities. The Louisiana SHPO concurred with this finding on March 17, 2014.

HRA submitted a third letter report to the Texas SHPO on March 28, 2014, containing the results of a cultural resources site file search and a recommendation that fieldwork was not required for the Supply Dock. The Texas SHPO concurred with this recommendation on April 22, 2014.

**TABLE 4.10.1-1**

**Golden Pass and SHPO Correspondence for the Golden Pass LNG Export Project**

<b>Date</b>	<b>Sender</b>	<b>Recipient</b>	<b>Correspondence</b>
<b>Louisiana</b>			
August 6, 2013	HRA	Louisiana SHPO	Letter including report of file search and recommendations
December 11, 2013	Louisiana SHPO	HRA	SHPO concurrence with no survey necessary
February 25, 2014	HRA	Louisiana SHPO	Letter including survey report and recommendations
March 17, 2014	Louisiana SHPO	HRA	SHPO concurrence with survey finding of no effect to historic properties
<b>Texas</b>			
August 6, 2013	HRA	Texas SHPO	Letter including report of file search and recommendations
August 27, 2013	Texas SHPO	HRA	SHPO concurrence with no survey required
February 25, 2014	HRA	Texas SHPO	Letter containing survey report and recommendations
March 14, 2014	Texas SHPO	HRA	SHPO concurrence with finding of no effect to historic properties
March 28, 2014	HRA	Texas SHPO	Letter containing survey report and recommendations
April 22, 2014	Texas SHPO	HRA	SHPO concurrence with finding of no effect to historic properties

**4.10.1.2 Federally Recognized Indian Tribes**

On December 11, 2013, Golden Pass sent letters to tribes requesting cultural resources consultation. The consultation request letters were sent to nine tribes: the Alabama-Coushatta Tribe of Texas, Caddo Nation of Oklahoma, Chitimacha Tribe of Louisiana, Coushatta Tribe of Louisiana, Jena Band of Choctaw Indians, Mississippi Band of Choctaw Indians, Quapaw Tribe of Indians, Tonkawa Tribe of Oklahoma, and Tunica-Biloxi Indians of Louisiana. As of publication of this draft EIS, no response has been received.

The FERC sent letters to eight of the tribes on August 22, 2014, inviting their participation in review of the Project. Letters were sent to the Alabama-Coushatta Tribe of Texas, Caddo Nation of Oklahoma, Chitimacha Tribe of Louisiana, Coushatta Tribe of Louisiana, Jena Band of Choctaw Indians, Mississippi Band of Choctaw Indians, Quapaw Tribe of Indians, and Tunica-Biloxi Indians of Louisiana. The FERC letter also requested their assistance in identifying properties of traditional, religious, or cultural importance. As of publication of this draft EIS, no response has been received.

**4.10.1.3 State-recognized Indian Tribes**

On December 11, 2013, Golden Pass sent consultation letters to six state-recognized tribes: the Adai Caddo Indians of Louisiana, Clifton Choctaw Tribe of Louisiana, United Houma Nation, Choctaw-Apache Community of Ebarb, Four Winds Tribe, and Talimali Band of Apalachee of Louisiana. As of publication of this draft EIS, no response has been received.

#### **4.10.2 Terminal Expansion**

Golden Pass completed cultural resources investigations during permitting of the existing Golden Pass Import Terminal; these investigations are summarized in the FERC final EIS (FERC, 2005). After review of the survey report provided for the existing terminal, on August 24, 2004, the Texas SHPO concurred with the finding that construction and operation of the Golden Pass Import Terminal would not affect any sites listed, or eligible for listing, in the NRHP.

Golden Pass subsequently completed a records review (Scott, 2013a) for the Terminal Expansion. The records review did not identify any known properties within the Terminal Expansion area that are listed, or eligible for listing, in the NRHP (Scott, 2013a). In a letter report submitted to the Texas SHPO on August 6, 2013, Scott (2013a) recommended that the Terminal Expansion area did not require a pedestrian survey. The Texas SHPO concurred with this recommendation on August 27, 2013.

Tuttle (2014) did not identify any cultural resources within the 1-mile-radius study area for the Supply Dock during a desktop study and recommended in a letter report that was submitted to the Texas SHPO on March 28, 2014, that the Project location did not require a pedestrian survey. The Texas SHPO concurred with this recommendation on April 22, 2014.

#### **4.10.3 Pipeline Expansion**

Golden Pass previously completed cultural resources investigations during the permitting of the existing Golden Pass Pipeline. As documented in the FERC final EIS (2005), the Texas SHPO and Louisiana SHPO reviewed the survey report provided for the existing Golden Pass Pipeline (Scott et al., 2009a, 2009b).

Golden Pass subsequently completed records reviews (Scott 2013a, 2013b) for the Terminal Expansion site (including the MP 1 Compressor Station), Calcasieu Loop, MP 33 Compressor Station, MP 66 Compressor Station, Tennessee Gas Interconnect, TETCO Interconnect, Transco Interconnect, and associated access roads. The records reviews did not identify any known properties in the Project area that are listed, or eligible for listing, in the NRHP. Scott (2013a, 2013b) recommended that the pipeline corridor did not require survey, as the proposed route would be located entirely within a previously investigated survey corridor.

Golden Pass completed pedestrian cultural resources surveys (Scott, 2013c) for the MP 33 Compressor Station, MP 66 Compressor Station, Tennessee Gas Interconnect, TETCO Interconnect, Transco Interconnect, and associated access roads based on the recommendation in Scott's (2013a, 2013b) records reviews. The surveys examined 69.3 acres for the MP 33 Compressor Station and 247.4 acres for the MP 66 Compressor Station, Tennessee Gas Interconnect, TETCO Interconnect, Transco Interconnect, and associated access roads. Surveys were conducted in areas that were not previously disturbed through channelization, levee construction, pipelines, or access road construction. The APE contained existing pipeline corridors, transmission lines, constructed canals and levees, and an access road, in addition to portions that had been used for agricultural purposes. No archaeological resources or standing structures were identified during these surveys.

#### **4.10.4 Unanticipated Discovery Plan**

Golden Pass prepared an acceptable UDP (see appendix D) for both Louisiana and Texas that would be implemented in the event that cultural resources, burials, and/or human remains would be encountered during construction. The UDP was submitted to the Louisiana and Texas SHPOs for their review. The Texas SHPO approved the UDP with minor revisions on December 13, 2013. The Louisiana SHPO approved the UDP on February 18, 2014.

#### **4.10.5 Compliance with the National Historic Preservation Act**

Cultural resource investigations and surveys have been completed for the Terminal Expansion and Pipeline Expansion, as appropriate. The Texas SHPO and the FERC agree that no historic properties would be adversely affected by the Terminal Expansion. The Louisiana SHPO and the FERC agree that no historic properties would be affected for the Pipeline Expansion. Therefore, the process of complying with Section 106 of the NHPA is complete for the Terminal Expansion and the Pipeline Expansion.

### **4.11 AIR QUALITY AND NOISE**

#### **4.11.1 Air Quality**

##### **4.11.1.1 Regional Climate**

The regional climate is a modified marine climate that can be influenced by a predominant onshore flow of tropical marine air from the Gulf of Mexico. During onshore flow events, the area experiences a subtropical, humid climate. In summer, sea breezes help to decrease temperatures. General climate conditions are comparable across the Project area, extending from the Terminal Expansion in Texas to the terminus of the Pipeline Expansion in Calcasieu Parish, Louisiana.

Based on 1981 to 2010 climate data from the National Climatic Data Center's Climatology of the United States, temperatures at the Jack Brooks Regional Airport in Beaumont, Texas (the data collection point that is closest to the Terminal Expansion), usually range from a monthly maximum average of 92.2 °F in August to a minimum monthly average of 43.2 °F in January. Mean annual precipitation falling at the Jack Brooks Regional Airport is 60.5 inches, while monthly average precipitation ranges from a minimum of 3.2 inches in April to a maximum of 7.1 inches in June. Thunderstorms occur in the area about 69 days per year, and the average annual snowfall is less than 0.1 inch. Winds in the area are generally from the south, with average wind speeds around 10 mph. Winds from the west-southwest through west-northwest are quite rare. Wind direction can vary by season: spring (March through May) winds are from the south through southeast, summer (June through August) winds are from the south through southwest, fall (September through November) winds are from the south counterclockwise through north, and winter (December through February) winds are predominantly from the north and frequently from the south-southeast and north-northeast (NCDC, 2010).

Maximum and minimum temperatures at the Lake Charles Regional Airport in Calcasieu Parish, Louisiana (the data collection point that is closest to the Pipeline Expansion), usually occur in August (at 91.9 °F monthly average maximum) and January (at 42.3 °F monthly average minimum). Mean annual precipitation falling at the Lake Charles Regional Airport is 57.5 inches, while monthly average precipitation ranges from a minimum of 3.3 inches in April to a maximum of 6.9 inches in June. Thunderstorms occur in the area about 76 days per year, and the average annual snowfall is less than 0.1 inch. Wind directions and speed in the area are similar to those of the Jack Brooks Regional Airport as the two airports are proximate (NCDC, 2010).

##### **4.11.1.2 Existing Air Quality**

###### **Ambient Air Quality Standards**

Air quality would be affected by construction activities and operation of the facilities. With authority granted by the CAA, the EPA (2012d) established National Ambient Air Quality Standards (NAAQS) to protect human health (primary standards) and public welfare (secondary standards). The EPA set the NAAQS for the following air contaminants designated as "criteria pollutants:" nitrogen oxides (NO<sub>x</sub>), including nitrogen dioxide (NO<sub>2</sub>); carbon monoxide (CO); ozone (O<sub>3</sub>); sulfur dioxide (SO<sub>2</sub>); lead

(Pb); particulate matter with an aerodynamic diameter less than or equal to 10 microns (PM<sub>10</sub>); and particulate matter with an aerodynamic diameter less than or equal to 2.5 microns (PM<sub>2.5</sub>). These NAAQS reflect the relationship between pollutant concentrations and health and welfare effects. The NAAQS are codified in 40 CFR 50 and are summarized in table 4.11.1-1. The LDEQ and the TCEQ have adopted the NAAQS.

<b>TABLE 4.11.1-1</b>				
<b>National, Texas, and Louisiana Ambient Air Quality Standards</b>				
<b>Pollutant</b>	<b>Timeframe</b>	<b>Primary</b>	<b>Secondary</b>	<b>Form</b>
PM <sub>10</sub>	Annual	Revoked	Revoked	NA
	24-hour	150 µg/m <sup>3</sup>	150 µg/m <sup>3</sup>	Not to be exceeded more than once per year on average over 3 years
PM <sub>2.5</sub>	Annual	12 µg/m <sup>3</sup>	15 µg/m <sup>3</sup>	Annual mean, averaged over 3 years
	24-hour	35 µg/m <sup>3</sup>	35 µg/m <sup>3</sup>	98 <sup>th</sup> percentile, averaged over 3 years
SO <sub>2</sub>	Annual	Revoked	NA	NA
	24-hour	Revoked	NA	NA
	3-hour	NA	0.5 ppm (1,300 µg/m <sup>3</sup> )	Not to be exceeded more than once per year
	1-hour	75 ppb (196 µg/m <sup>3</sup> )	NA	99 <sup>th</sup> percentile of 1-hour daily maximum concentrations, averaged over 3 years
CO	8-hour	9 ppm (10,000 µg/m <sup>3</sup> )	NA	Not to be exceeded more than once per year
	1-hour	35 ppm (40,000 µg/m <sup>3</sup> )	NA	Not to be exceeded more than once per year
NO <sub>2</sub>	Annual	0.053 ppm (100 µg/m <sup>3</sup> )	0.053 ppm (100 µg/m <sup>3</sup> )	Annual mean
	1-hour	0.100 ppm (188 µg/m <sup>3</sup> )	NA	98 <sup>th</sup> percentile of 1-hour daily maximum concentrations, averaged over 3 years
O <sub>3</sub>	8-hour	0.075 ppm (147 µg/m <sup>3</sup> )	0.075 ppm (147 µg/m <sup>3</sup> )	Annual fourth-highest daily maximum 8-hour concentration, averaged over 3 years
	1-hour <u>a</u>	0.12 ppm	0.12 ppm	Not to be exceeded more than once per calendar year
Pb	Rolling 3 month average	0.15 µg/m <sup>3</sup>	0.15 µg/m <sup>3</sup>	Not to be exceeded

**TABLE 4.11.1-1 (continued)**

**National, Texas, and Louisiana Ambient Air Quality Standards**

Source: EPA, 2012d

Abbreviations:

PM <sub>10</sub> = particulate matter less than 10 microns	µg = microgram(s)
PM <sub>2.5</sub> = particulate matter less than 2.5 microns	mg = milligram(s)
CO = carbon monoxide	m <sup>3</sup> = cubic meter(s)
NO <sub>2</sub> = nitrogen dioxide	ppm = part(s) per million
SO <sub>2</sub> = sulfur dioxide	ppb = part(s) per billion
O <sub>3</sub> = ozone	NA = not applicable
Pb = lead	

Note:

**a** The 1-hr O<sub>3</sub> standard was revoked by the EPA in 1993. However, the standard is presented in the table as a reference because Calcasieu Parish (where the Pipeline Expansion would be located) is subject to maintenance for the 1-hour O<sub>3</sub> for purposes of 40 CFR 51 Subpart X (see related discussion under “Air Quality Control Regions and Attainment Status” paragraph below.

In December 2009, the EPA updated the definition of air pollution to include six GHGs after determining that GHGs in the atmosphere can endanger public health and welfare. The GHGs include CO<sub>2</sub>, methane (CH<sub>4</sub>), nitrous oxide (N<sub>2</sub>O), hydrofluorocarbons, perfluorocarbons, and sulfur hexafluoride. GHGs produced by fossil fuel combustion include CO<sub>2</sub>, CH<sub>4</sub>, and N<sub>2</sub>O. GHG emissions typically are expressed in terms of carbon dioxide equivalents (CO<sub>2</sub>-eq), where the potential of each gas to increase heating in the atmosphere is expressed as a multiple of the heating potential of CO<sub>2</sub>, termed its “global warming potential” (GWP). Thus, CO<sub>2</sub> has a GWP of 1; in comparison, CH<sub>4</sub> has a GWP of 25, and N<sub>2</sub>O has a GWP of 298.<sup>28</sup>

**Air Quality Control Regions and Attainment Status**

An “Air Quality Control Region” (AQCR), as defined in the CAA (42 USC 7407), is a contiguous area considered to have relatively uniform ambient air quality that is treated as a single unit for reducing air emissions and determining compliance with the NAAQS. Each AQCR, or smaller portion within an AQCR, is designated as attainment, unclassifiable, maintenance, or nonattainment. Areas where ambient air pollutant concentrations are below the NAAQS are designated as attainment, while areas where ambient air concentrations are greater than the NAAQS are designated as nonattainment. Areas that were previously designated as nonattainment and have since demonstrated compliance with an NAAQS are designated as “maintenance” for a period of time (normally 20 years after the effective date of attainment); this time period assumes that the area remains in compliance with the standard. Areas without data available are designated as unclassifiable and are treated as attainment areas for the purpose of stationary source air permitting.

The Project would be constructed in Jefferson and Orange Counties, Texas, and Calcasieu Parish, Louisiana, which are within the Southern Louisiana-Southeast Texas Interstate, AQCR 106. Jefferson and Orange Counties in Texas are within the Beaumont-Port Arthur (BPA) area previously classified as nonattainment for the 1979 1-hour O<sub>3</sub> standard. However, the 1-hour O<sub>3</sub> standard was revoked effective June 15, 2005, for Jefferson and Orange Counties. Effective November 19, 2010, Jefferson and Orange

<sup>28</sup> On November 29, 2013, the EPA revised GWPs for GHGs to reflect more accurate GWPs from the Intergovernmental Panel for Climate Change Fourth Assessment Report; to better characterize the climate impacts of individual GHGs; and to ensure continued consistency with other U.S. climate programs, including the Inventory U.S. Greenhouse Gas Emissions and Sinks. More information is available in Volume 78 of the Federal Register, Issue 230.

Counties were classified as attainment (redesignated as maintenance) for the 1997 8-hour O<sub>3</sub> NAAQS. Jefferson and Orange Counties were designated unclassifiable/attainment under the 2008 eight-hour ozone NAAQS, effective July 20, 2012. On March 6, 2015, EPA issued a final rulemaking for implementation of the 2008 8-hour O<sub>3</sub> standard. In this rulemaking, EPA also revoked the 1997 8-hour O<sub>3</sub> standard, effective 30 days after the final rulemaking. The rulemaking also explains that General Conformity requirements for the 1997 8-hour O<sub>3</sub> standard end upon the revocation of the standard, regardless of whether an area was designated non-attainment or maintenance for the 1997 standard. Anti-backsliding requirements do not apply to general conformity.

Calcasieu Parish is classified as attainment for all criteria pollutants (40 CFR 81.319). Project-related marine emissions also could occur within the Houston-Galveston-Brazoria (HGB) area, which is classified as a marginal nonattainment area for the 2008 8-hour O<sub>3</sub> standard.

To maintain a status of attainment, measures must be taken to track emissions data for all criteria pollutants. The TCEQ has established a maximum allowable emission level of 100 tons per year (tpy) for volatile organic compounds (VOC) and NO<sub>x</sub>, which are precursors for ozone, on projects within areas classified as maintenance. Currently, no provisions or emissions thresholds associated with the maintenance designation of Calcasieu Parish require compliance by the Project. According to 40 CFR 93.153(b)(1), conformity determination thresholds for VOC and NO<sub>x</sub> for marginal nonattainment are 100 tpy (TCEQ, 2013b; EPA, 2014b). See related discussion under General Conformity in section 4.11.1.3.

### **Air Quality Monitoring and Existing Air Quality**

The EPA, along with state and local agencies, created a network of ambient air quality monitoring stations that collect data on background concentrations of priority pollutants across the United States. To characterize the existing ambient air quality for the Project, available data were gathered from air quality monitoring stations that are nearest to the Project. The most recent validated data from these monitoring sites are presented in table 4.11.1-2, which compares the highest monitored data with the appropriate NAAQS standard for each criteria pollutant. All monitored data were below the NAAQS, except for the 8-hour O<sub>3</sub> value averaged during the 3-year period from 2011 through 2013. This average 8-hour O<sub>3</sub> result of 76 ppb (1 ppb slightly above the O<sub>3</sub> NAAQS) was calculated from the Sabine Pass monitoring station data.

### **Emissions from the Golden Pass Import Terminal**

Table 4.11.1-3 lists the criteria air pollutant potential emissions from the existing terminal.

**TABLE 4.11.1-2**

**Baseline Ambient Air Quality and Ambient Air Quality Standards  
for the Golden Pass LNG Export Project a**

<b>Air Pollutant</b>	<b>Averaging Period</b>	<b>Highest Monitored Value</b>	<b>Year</b>	<b>Monitoring Site Name (ID)</b>	<b>NAAQS</b>
<b>Terminal Expansion – Jefferson and Orange Counties, Texas</b>					
PM <sub>10</sub>	24-hour	93 µg/m <sup>3</sup>	2011 – 2013 <b>b</b>	Texas City Fire Station (481670004)	150 µg/m <sup>3</sup>
PM <sub>2.5</sub>	Annual	10.5 µg/m <sup>3</sup>	2008 – 2010 <b>c</b>	Port Arthur Memorial School (482450021)	15 µg/m <sup>3</sup>
	24-hour	26.7 µg/m <sup>3</sup>	2008 – 2010 <b>c</b>	Port Arthur Memorial School (482450021)	35 µg/m <sup>3</sup>
SO <sub>2</sub>	1-hour	53 ppb	2011 – 2013 <b>c</b>	Port Arthur West (482450011)	75 ppb
CO	1-hour	0.7 ppm	2013 <b>d</b>	Nederland High School (482451035)	35 ppm
	8-hour	0.6 ppm	2013 <b>d</b>	Nederland High School (482451035)	9 ppm
NO <sub>2</sub>	Annual	11.2 ppb <b>e</b>	2013	Nederland High School (482451035)	53 ppb
	1-hour	25 ppb	2011 – 2013 <b>c</b>	Nederland High School (482451035)	100 ppb
O <sub>3</sub>	8-hour	76 ppb	2011 – 2013 <b>c</b>	Sabine Pass (482450101)	75 ppb
Pb <b>f</b>	24-hour	0.011 µg/m <sup>3</sup>	2013	Houston East (482011034)	0.15 µg/m <sup>3</sup>
<b>Pipeline Expansion – Calcasieu Parish, Louisiana</b>					
PM <sub>10</sub>	24-hour	74 µg/m <sup>3</sup>	2011 – 2013 <b>b</b>	La Fayette (220550007)	150 µg/m <sup>3</sup>
PM <sub>2.5</sub>	Annual	8.4 µg/m <sup>3</sup>	2011 – 2013 <b>c</b>	Lake Charles – McNeese (220190010)	15 µg/m <sup>3</sup>
	24-hour	19 µg/m <sup>3</sup>	2011 – 2013 <b>c</b>	Lake Charles – McNeese (220190010)	35 µg/m <sup>3</sup>
SO <sub>2</sub>	1-hour	37 ppb	2011 – 2013 <b>c</b>	West Lake (220190008)	75 ppb
CO	1-hour	2.1 ppm	2013 <b>d</b>	Baton Rouge (220330009)	35 ppm
	8-hour	2 ppm	2013 <b>d</b>	Baton Rouge (220330009)	9 ppm



**TABLE 4.11.1-2 (continued)**

**Baseline Ambient Air Quality and Ambient Air Quality Standards  
for the Golden Pass LNG Export Project a**

<b>Air Pollutant</b>	<b>Averaging Period</b>	<b>Highest Monitored Value</b>	<b>Year</b>	<b>Monitoring Site Name (ID)</b>	<b>NAAQS</b>
NO <sub>2</sub>	Annual	11.1 ppb <u>e</u>	2013	West Lake (220190008)	53 ppb
	1-hour	30 ppb	2011 – 2013 <u>c</u>	West Lake (220190008)	100 ppb
Ozone (O <sub>3</sub> )	1-hour	104 ppb <u>h</u>	2011 – 2013	West Lake (220190008)	120 ppb <u>g</u>
	8-hour	67 ppb	2011 – 2013 <u>c</u>	West Lake (220190008)	75 ppb
Pb <u>f</u>	24-hour	0.005 µg/m <sup>3</sup>	2013	Baton Rouge (220330009)	0.15 µg/m <sup>3</sup>

Sources: EPA, 2013c; TCEQ, 2014e; LDEQ, 2014c

Abbreviations:

ppb = parts per billion

ppm = parts per million

µg/m<sup>3</sup> = micrograms per cubic meter

NAAQS = National Ambient Air Quality Standards

NA= not available

Notes:

a Data collected from monitoring stations closest to the Project.

b Value shown for PM<sub>10</sub> is the highest of the first maximum readings for each year from 2011 through 2013.

c Values shown are averaged over 3 years.

d Values shown for CO are the highest of the first maximum readings in 2013.

e Values shown for annual NO<sub>2</sub> are the annual mean of the daily maximum readings in 2013.

f The NAAQS of 0.15 µg/m<sup>3</sup> for Pb is not to be exceeded, based on a 3-month rolling average. However, the rolling 3-month average statistic is currently not available. The value shown is the 2013 annual first maximum based on 24-hour period average data taken from the nearest available Pb monitoring station to the Project site.

g The NAAQS for 1-hour O<sub>3</sub> has been revoked effective June 15, 2005, in all areas of Louisiana. However, the Lake Charles area (Calcasieu Parish) is designated as maintenance for 1-hour O<sub>3</sub> NAAQS (120 ppb, not to be exceeded more than 1 day per calendar year) for purposes of 40 CFR 51 Subpart X (Provisions for Implementation of 8-hour Ozone National Ambient Air Quality Standard).

h The representative ambient value for 1-hour O<sub>3</sub> shown for Calcasieu Parish is the highest of first maximum 1-hour averages from 2011 through 2013; no exceedances occurred during this period.

TABLE 4.11.1-3							
Potential-to-Emit for the Golden Pass Import Terminal							
Emission Unit (Quantity)	Pollutant Emissions (tpy)						
	NO <sub>x</sub>	CO	SO <sub>2</sub>	PM <sub>10</sub> / PM <sub>2.5</sub>	VOC	HAPs	CO <sub>2</sub> -eq
Heat transfer fluid heater (8)	46.5	93.0	6.1	46.5	34.3	--	--
Diesel firewater pump (2)	0.6	0.1	0.1	<0.1	<0.1	--	--
Diesel emergency generator (1)	1.3	0.2	0.2	<0.1	<0.1	--	--
Storage tanks (4)	0.0	0.0	0.0	0.0	<0.1	--	--
Process fugitives	0.0	0.0	0.0	0.0	1.8	--	--
<b>TOTAL</b>	<b>48.5</b>	<b>93.3</b>	<b>6.2</b>	<b>46.5</b>	<b>36.1</b>	--	--
<u>Abbreviations:</u>							
NO <sub>x</sub> = oxides of nitrogen			CO = carbon monoxide				
SO <sub>2</sub> = sulfur dioxide			PM <sub>10</sub> = particulate matter less than 10 microns				
VOC = volatile organic compounds			PM <sub>2.5</sub> = particulate matter less than 2.5 microns				
HAPs = hazardous air pollutants			CO <sub>2</sub> -eq = carbon dioxide equivalents				
tpy = tons per year			-- = no emissions data				

#### 4.11.1.3 Regulatory Requirements for Air Quality

##### Terminal Expansion and MP 1 Compressor Station

###### Federal Air Quality Requirements

**New Source Review/Prevention of Significant Deterioration.** New Source Review (NSR) is a pre-construction permitting program to ensure that air quality is not significantly degraded when a new source of air pollution is constructed, or an existing source is modified, such that air pollutant emissions are increased. NSR permits are legal documents that authorize a permittee to construct a source of emissions. Federal pre-construction review of certain large proposed projects varies for attainment and nonattainment areas. Federal pre-construction review for major sources in nonattainment areas is referred to as "Nonattainment New Source Review," while federal pre-construction review for sources in attainment areas is formally referred to as "PSD." A minor NSR permit is required as a pre-construction authorization for minor sources whose emissions are below the major source thresholds (see table 4.11.1-4). The review process aids in preventing new sources from causing existing air quality to deteriorate beyond acceptable levels.

TABLE 4.11.1-4

Major Stationary Source/Major Modification Emission Thresholds

Pollutant	Major Stationary Source Threshold Level (tpy)	Major Modification Significant Net Increase (tpy)
O <sub>3</sub> /VOC/NO <sub>x</sub>	250	40
CO	250	100
SO <sub>2</sub>	250	40
PM	250	25
PM <sub>10</sub>	250	15
PM <sub>2.5</sub>	250	10
Pb	250	0.6
GHG <b>a</b>	250 tpy GHGs <b>a, b</b>	75,000 tpy CO <sub>2</sub> -eq / >0 tpy GHGs <b>c</b>
<p><u>Abbreviations:</u></p> <p>O<sub>3</sub> = ozone            NO<sub>x</sub> = oxides of nitrogen            SO<sub>2</sub> = sulfur dioxide            PM<sub>10</sub> = particulate matter less than 10 microns            Pb = lead            GHG = greenhouse gas</p> <p>VOC = volatile organic compounds            CO = carbon monoxide            PM = particulate matter            PM<sub>2.5</sub> = particulate matter less than 2.5 microns            tpy = tons per year            CO<sub>2</sub>-eq = carbon dioxide equivalents</p> <p><u>Notes:</u></p> <p><b>a</b> This list reflects the July 24, 2014 EPA Guidance indicating that EPA will no longer treat GHGs as air pollutants for purposes of determining whether a source is a major source required to obtain a PSD or Title V permit. See footnotes 29 and 30 (EPA, 2014b, 2014c).</p> <p><b>b</b> A facility is considered a major stationary source if the PTE is greater than 250 tpy of GHG (sum of six GHGs on a mass basis).</p> <p><b>c</b> A major modification must meet two emission conditions: must be greater than 75,000 tpy of CO<sub>2</sub>-eq and exceed 0 tpy of GHG (sum of six GHGs on a mass basis).</p>		

The emissions thresholds triggering a PSD review and permitting are listed below.

- For GHG emissions,<sup>29, 30</sup> a source is subject to PSD review if:
- it is otherwise subject to PSD (for another regulated pollutant) and has a potential-to-emit (PTE) greater than or equal to 75,000 tpy CO<sub>2</sub>-eq; or
- it has a PTE greater than or equal to 100 tpy (if classified in one of the 28 named source categories listed in Section 169 of the CAA) or 250 tpy for any other type of source.

<sup>29</sup> On June 23, 2014, the U.S. Supreme Court issued its decision in *Utility Air Regulatory Group v. EPA* (No. 12-1146) that the EPA may not treat GHGs as an air pollutant for purposes of determining whether a source is a major source required to obtain a PSD or Title V Permit. PSD Permits that are otherwise required (based on emissions of other pollutants) may continue to require limitations on GHG emissions based on the application of BACT (EPA, 2014b).

<sup>30</sup> On July 24, 2014, the EPA issued a guidance memorandum (*Next Steps and Preliminary Views on the Application of Clean Air Act Permitting Programs to Greenhouse Gases Following the Supreme Court's Decision in Utility Air Regulatory Group versus EPA*) stating that the EPA will no longer require PSD or Title V Permits for Step 2 sources (sources and modifications previously classified as "major" based solely on GHG emissions). As such, the EPA would not continue to process PSD or Title V Permit applications for Step 2 sources or require new applications for such permits in cases where the EPA is the permitting authority (EPA, 2014c).

- For regulated pollutants other than GHGs, a source is subject to PSD review if it emits more than 100 tpy (if classified in one of the 28 named source categories listed in Section 169 of the CAA) of the regulated air pollutant, or 250 tpy of the regulated air pollutant for any other type of source.
- For a source subject to PSD review for one regulated pollutant, the source is also subject to PSD review for all other pollutants causing a significant increase in emissions level.

The Terminal Expansion and MP 1 Compressor Station do not fall under a listed source category, but the facilities are considered a major source because they have the potential to emit more than 250 tpy of a pollutant regulated under the CAA and more than the de minimis level of 75,000 tpy of CO<sub>2</sub>-eq. The Terminal Expansion and MP 1 Compressor Station would not be located in a nonattainment area for any regulated criteria pollutant; therefore, a Nonattainment New Source Review would not be triggered, but a PSD review would be required. Table 4.11.1-4 lists major source emission thresholds, and table 4.11.1-5 summarizes the PTE based on all air pollution-emitting equipment that would be used for the MP 1 Compressor Station and the Terminal Expansion. Because the Terminal Expansion and the MP 1 Compressor Station would be adjacent to the existing Golden Pass Import Terminal, these three facilities would be deemed a single site.<sup>31</sup>

TABLE 4.11.1-5							
Potential-to-Emit for the Terminal Expansion and MP 1 Compressor Station							
Emission Unit (Quantity)	Pollutant Emissions (tpy)						
	NO <sub>x</sub>	CO	SO <sub>2</sub>	PM <sub>10</sub> / PM <sub>2.5</sub>	VOC	HAPs	GHG
<b>Terminal Expansion</b>							
Gas turbine/heating recovery steam generator (6) and MSS emissions	572.3	421.7	5.8	115.5	159.1	15.9	3,687,198
Thermal oxidizers (4)	38.1	5.3	3.3	1.5	20.2	3.0	1,124,904
Diesel essential generators (7 units – 40 hours per year each)	7.6	4.2	<0.1	0.2	0.3	<0.1	829
Auxiliary boiler (1 unit – 1,440 hours per year) and MSS emissions	5.0	7.8	<0.1	1.7	0.9	0.3	20,369
LNG storage LP flare	8.4	67.2	0.1	--	0.9	0.2	17,861
Wet/dry gas ground flare and MSS emissions	39.4	337.5	0.1	--	15.4	0.1	85,853

<sup>31</sup> As defined in the Texas Administrative Code Title 30 Part 1 Chapter 122 Subchapter A, “site” means the total of all stationary sources located on one or more contiguous or adjacent properties, which are under common control of the same person (or persons under common control), and “stationary source” means any building, structure, facility, or installation that emits or may emit any air pollutant.

**TABLE 4.11.1-5 (continued)**

**Potential-to-Emit for the Terminal Expansion and MP 1 Compressor Station**

Emission Unit (Quantity)	Pollutant Emissions (tpy)						
	NO <sub>x</sub>	CO	SO <sub>2</sub>	PM <sub>10</sub> / PM <sub>2.5</sub>	VOC	HAPs	GHG
Storage tanks (10)	--	--	--	--	0.1	--	--
Condensate storage tank loading (1)	--	--	--	--	0.4	--	--
Truck loading	--	--	--	--	1.1	--	--
Fugitive emissions (valves, flanges/connectors, compressors)	--	--	--	--	58.2	--	2,789
<b>MP 1 Compressor Station</b>							
Blowdown vent (2 events per year)	--	--	--	--	0.1	--	218
NG essential generator (1 unit – 100 hours per year)	0.1	0.3	<0.1	<0.1	<0.1	<0.1	10
Fugitive emissions (valves, flanges/connectors, compressors)	--	--	--	--	1.6	--	36
Condensate storage tank loading	--	--	--	--	0.1	--	--
Truck loading	--	--	--	--	<0.1	--	--
<b>TOTAL</b>	<b>670.9</b>	<b>844.0</b>	<b>9.3</b>	<b>118.9</b>	<b>258.4</b>	<b>19.5</b>	<b>4,940,067</b>
<u>Abbreviations:</u>							
NO <sub>x</sub> = oxides of nitrogen				CO = carbon monoxide			
SO <sub>2</sub> = sulfur dioxide				PM <sub>10</sub> = particulate matter less than 10 microns			
VOC = volatile organic compounds				HAPs = hazardous air pollutants			
MSS = maintenance, startup, and shutdown				NG = Natural Gas			
tpy = tons per year				-- = no emissions data			
MSS = maintenance, startup, and shutdown							
GHG = greenhouse gas, as CO <sub>2</sub> equivalent (CO <sub>2</sub> -eq, including CO <sub>2</sub> , CH <sub>4</sub> , and N <sub>2</sub> O), rounded to nearest whole number							

There are three air quality classifications within each of the AQCRs of the United States: Class I areas are designated as pristine natural areas or areas of natural significance and receive special protections under the CAA based on good air quality. Class III areas are heavily industrialized zones that are established only on request and must meet all requirements outlined in 40 CFR 51.166. The remainder of the United States is designated as Class II. If a new source or major modification of an existing source is subject to the PSD program requirements and is within 62 miles (100 kilometer [km]) of a Class I area, the facility is required to notify the appropriate federal officials and assess the impacts of the Project on the Class I area. The closest designated Class I area to the Project is the Breton NWR, about 300 miles east of the Project site; therefore, a PSD Class I analysis is not required.

As shown in table 4.11.1-4, the Terminal Expansion and MP 1 Compressor Station would be a PSD major source, as the projected emissions for NO<sub>x</sub>, CO, and CO<sub>2</sub>-eq are above the major stationary thresholds

shown in table 4.11.1-3. Golden Pass submitted an application to TCEQ for a state and PSD air quality permit for the Terminal Expansion and MP 1 Compressor Station on December 23, 2013, and submitted updated PSD permit applications on April 8, 2014, and October 3, 2014. In addition, Golden Pass has filed a GHG PSD application with the EPA Region 6, which includes proposed Best Available Control Technology (BACT) for GHG. On November 10, 2014, the EPA officially transferred GHG permitting authority to the TCEQ. Golden Pass requested that the GHG permit application for the Project be transferred to the TCEQ for review. On January 16, 2015, the TCEQ issued Permits 116055 and PSDTX1386 to Golden Pass, authorizing construction and operation of the expanded terminal.

**New Source Performance Standards.** The New Source Performance Standards (NSPS), codified in 40 CFR 60, regulate emission rates and provide requirements for new or significantly modified sources. NSPS requirements include emission limits, monitoring, reporting, and record keeping.

Applicable NSPS for the Project, based on the types of emission units and the expected date of installation, would potentially include, but not be limited to, the following:

- 40 CFR 60 Subpart A – General Provisions. Subpart A contains the general requirements applicable to all emission units subject to 40 CFR 60.
- 40 CFR 60 Subpart Db – Standards of Performance for Industrial-Commercial-Institutional Steam Generating Units. Subpart Db applies to each steam-generating unit that commences construction, modification, or reconstruction after June 19, 1984, and has a heat input capacity from fuels combusted in the steam-generating unit of greater than 29 MW (100 million British thermal units per hour [MMBtu/hr]). This subpart sets standards for oxides of nitrogen, PM, and sulfur dioxide emissions. This subpart may apply to the boiler at the Terminal Expansion.
- 40 CFR Subpart Kb – Standards of Performance for Volatile Organic Liquid Storage Vessels (including Petroleum Liquid Storage Vessels). This subpart applies to each storage vessel with a capacity greater than or equal to 75 m<sup>3</sup> that is used to store volatile organic liquids for which construction, reconstruction, or modification was commenced after July 23, 1984. This subpart does not apply to storage vessels with a capacity greater than or equal to 151 m<sup>3</sup> storing a liquid with a maximum true vapor pressure less than 3.5 kilopascals, or with a capacity greater than or equal to 75 m<sup>3</sup> but less than 151 m<sup>3</sup> storing a liquid with a maximum true vapor pressure less than 15.0 kilopascals. This subpart sets standards for VOC emissions reduction. This subpart may apply to the storage tanks at the Terminal Expansion and MP 1 Compressor Station.
- 40 CFR 60 Subpart IIII – Standards of Performance for Stationary Compression Ignition Internal Combustion Engines (CI ICE). Subpart IIII applies to owners and operators of stationary CI ICE that commenced construction after July 11, 2005, where the stationary CI ICE are manufactured after April 1, 2006, and are not fire pump engines. This subpart sets emission standards for oxides of nitrogen and nonmethane hydrocarbons, hydrocarbons, oxides of nitrogen, carbon monoxide, and PM. This subpart may apply to the diesel engines at the Terminal Expansion.
- 40 CFR 60 Subpart JJJJ – Standards of Performance for Stationary Spark Ignition Internal Combustion Engines (SI ICE). Subpart JJJJ applies to owners and operators of stationary SI ICE that commenced construction after June 12, 2006, where the stationary SI ICE were manufactured on or after July 1, 2007. This subpart sets emission standards for oxides of nitrogen, carbon monoxide, and VOC. This subpart may apply to the natural gas-fired engines at the MP 1 Compressor Station.
- 40 CFR 60 Subpart KKKK – Standards of Performance for Stationary Gas Turbines with a heat input at peak load equal to or greater than 10.7 gigajoules (10 MMBtu) per hour, based on the higher heating value of the fuel fired, which commenced construction, modification, or

reconstruction after February 18, 2005. This subpart sets emission standards for oxides of nitrogen and sulfur dioxide. This subpart may apply to the turbines at the Terminal Expansion.

- 40 CFR 60 Subpart OOOO – Standards of Performance for Crude Oil and Natural Gas Production, Transmission and Distribution. This subpart establishes emission standards and compliance schedules for the control of VOCs and SO<sub>2</sub> emissions from affected facilities that commenced construction, modification or reconstruction after August 23, 2011. Affected facilities include gas wells, centrifugal and reciprocating compressors, pneumatic controllers, condensate and crude oil storage tanks, and natural gas processing plants. This subpart may apply to the MP 1 Compressor Station.

**National Emissions Standards for Hazardous Air Pollutants.** The National Emissions Standards for Hazardous Air Pollutants (NESHAPs), codified in 40 CFR 61 and 63, regulate the emissions of hazardous air pollutants (HAPs) from new and existing sources. Part 61, promulgated before the 1990 CAA Amendments, regulates eight hazardous substances: asbestos, benzene, beryllium, coke oven emissions, inorganic arsenic, mercury, radionuclides, and vinyl chloride.

The 1990 CAA Amendments established a list of 189 HAPs, resulting in the promulgation of Part 63, also known as the Maximum Achievable Control Technology standards. Part 63 regulates HAPs from major sources of HAPs and specific source categories emitting HAPs. Some NESHAPs may apply to non-major sources (area sources) of HAPs. Major source thresholds for NESHAPs are 10 tpy of any single HAP or 25 tpy of total HAPs.

Applicable NESHAPs for the Project, based on the types of emission units and the expected date of installation, would potentially include, but not be limited to, the following:

- 40 CFR 63 Subpart A – General Provisions. Subpart A contains the general requirements applicable to all emission units subject to 40 CFR 63.
- 40 CFR 63 Subpart ZZZZ – NESHAPs for Stationary Reciprocating Internal Combustion Engines (RICE). Subpart ZZZZ applies to any existing, new, or reconstructed stationary RICE located at a major or area source of HAP emissions. For stationary RICE located at an area source of HAP emissions, a stationary RICE is “existing” if construction or reconstruction of the stationary RICE commenced before June 12, 2006. A stationary RICE located at an area source of HAP emissions is “new” if construction of the stationary RICE commenced on or after June 12, 2006. For area sources, this subpart sets operating limitations and emission limitations for carbon monoxide and formaldehyde, as well as management practices and work practice standards. This subpart may apply to the RICE engines that would be operated at the Terminal Expansion and MP 1 Compressor Station.

**Title V Operating Permit.** The required elements of Title V operating permit programs are outlined in 40 CFR 70 and 40 CFR 71. Title V operating permits may be referred to as “Part 70” or “Part 71” permits, or as Title V permits. A Title V permit should list all air pollution requirements that apply to the source, including emissions limits and monitoring, record keeping, and reporting requirements. Regulations also require that the permittee annually report the compliance status of its source with respect to permit conditions to the corresponding regulatory agency. In this case, the EPA has delegated to the TCEQ the authority to issue Title V permits.

The definition of a “major source”<sup>32</sup> under Title V varies according to which pollutants are emitted from the source and the attainment designation of the area where the source is located. In general, a source is considered major for Title V if it emits or has the potential to emit 100 tpy or more of any regulated pollutant; 10 tpy or more of any single HAP; 25 tpy or more total HAPs; or 100,000 tpy of CO<sub>2</sub>-eq and 100 tpy GHGs on a mass basis.

A Title V major source, as defined in 40 CFR 70.2, is a source or group of stationary sources (including new and existing sources) within a contiguous area and under common control, emitting or with the potential to emit criteria pollutants or HAPs above the criteria pollutant threshold values (100 tpy for any of the criteria pollutants, 10 tpy for any single HAP, or 25 tpy for any combination of HAPs). As shown in tables 4.11.1-3 and 4.11.1-5, total emissions from the Terminal Expansion, MP 1 Compressor Station, and the existing terminal would exceed Title V thresholds; therefore, these facilities would be subject to Title V permitting.

**General Conformity.** The General Conformity Rule was designed to require federal agencies to ensure that federally funded or federally approved projects conform to the applicable State Implementation Plan (SIP). Section 176(c) of the CAA prohibits federal actions in nonattainment or PSD maintenance areas that do not conform to the SIP for the attainment and maintenance of the NAAQS. General Conformity regulations apply to Project-wide emissions of pollutants for which the Project areas are designated as nonattainment (or, for ozone, its precursors NO<sub>x</sub> and VOC) that are not subject to NSR and that are greater than the significance thresholds established in the General Conformity regulations or 10 percent of the total emissions budget for the entire nonattainment area. Federal agencies are able to make a positive conformity determination for a proposed project if any of several criteria in the General Conformity Rule are met. These criteria include:

- emissions from the project that are specifically identified and accounted for in the SIP attainment or maintenance demonstration; or
- emissions from the action that are fully offset within the same area through a revision to the SIP, or a similarly enforceable measure that creates emissions reductions so there is no net increase in emissions of that pollutant.

We have conducted a General Conformity applicability determination for the Project with the following findings, specifically for the HGB area. The HGB area is a marginal nonattainment area for the 2008 8-hour O<sub>3</sub> standard. Project-related marine emissions would occur within this area; however, as shown in table 4.11.1-6, these emissions would not exceed the NO<sub>x</sub> and VOC emissions conformity determination thresholds of 100 tpy for marginal nonattainment. Therefore, a General Conformity determination would not apply to the Project.

See table 4.11.1-6 for demonstration of applicability of General Conformity rules for the BPA maintenance and HGB marginal and severe nonattainment areas for O<sub>3</sub>.

---

<sup>32</sup> Under the TCEQ rules, the term “major source” refers to the entire site. (See also footnote 31(See also footnote 31.) Whether a site is a major source is determined by calculating and summing emissions from all stationary sources at the site. The term “stationary source” includes facilities.



TABLE 4.11.1-6								
Summary of Construction Emissions by Area Classification for the Golden Pass LNG Export Project								
Area Affected	Year	Annual Pollutant Emissions (tpy)						
		NO <sub>x</sub>	CO	SO <sub>2</sub>	PM <sub>10</sub>	PM <sub>2.5</sub>	VOC	GHG
Total within HGB	2016	0.0	0.0	0.0	0.0	0.0	0.0	0.0
Nonattainment Area <u>a</u>	2017	0.0	0.0	0.0	0.0	0.0	0.0	0.0
	2018	1.4	1.0	0.0	0.1	0.1	0.1	140
	2019	1.4	1.0	0.0	0.1	0.1	0.1	140
	2020	1.0	0.7	0.0	0.0	0.0	0.0	95
<u>Abbreviations:</u>								
NO <sub>x</sub> = oxides of nitrogen				CO = carbon monoxide				
SO <sub>2</sub> = sulfur dioxide				PM <sub>10</sub> = particulate matter less than 10 microns				
PM <sub>2.5</sub> = particulate matter less than 2.5 microns				VOC = volatile organic compounds				
tpy = tons per year								
GHG = greenhouse gas, as CO <sub>2</sub> equivalent (CO <sub>2</sub> -eq, including CO <sub>2</sub> , CH <sub>4</sub> , and N <sub>2</sub> O), rounded to whole numbers								
<u>Notes:</u>								
<b>a</b>	Total construction emissions within the Houston-Galveston-Brazoria (HGB) nonattainment area include only emissions from marine operations.							

**Greenhouse Gases Reporting Rule.** In September 2009, the EPA issued the final Mandatory Reporting of Greenhouse Gases Rule, requiring reporting of GHG emissions from suppliers of fossil fuels and facilities that emit greater than or equal to 25,000 metric tpy of GHG (reported as CO<sub>2</sub>-eq). In November 2010, the EPA signed a rule finalizing GHG reporting requirements for the petroleum and natural gas industry in 40 CFR 98, Subpart W. The industry separates LNG storage facilities from LNG import and export equipment because the former are considered part of the source category regulated by Subpart W. The rule does not apply to construction emissions.

The new LNG facilities associated with the Terminal Expansion and the MP 1 Compressor Station would potentially be subject to the GHG Mandatory Reporting Rule. The rule establishes reporting requirements based on actual emissions; however, it does not require emission controls. Golden Pass would need to monitor emissions in accordance with the reporting rule. If actual emissions exceed the 25,000-metric-tpy CO<sub>2</sub>-eq reporting threshold, Golden Pass would be required to report its GHG emissions to the EPA.

Applicable State Air Quality Requirements

The Terminal Expansion facilities and MP 1 Compressor Station would be subject to state standards, codified in Texas Administrative Code (TAC) Title 30, Part I (TAC, 2014). The regulations listed below would apply to the new emission units and Project-related fugitive emissions associated with the Terminal Expansion and MP 1 Compressor Station, as well as to the existing terminal facilities:

- Chapter 101 – General Rules;
- Chapter 111 – Control of Air Pollution from Visible Emissions and Particulate Matter;
- Chapter 112 – Control of Air Pollution from Sulfur Compounds;

- Chapter 113 – Control of Air Pollution From Toxic Materials;
- Chapter 114 – Control of Air Pollution From Motor Vehicles;
- Chapter 115 – Control of Air Pollution From Volatile Organic Compounds;
- Chapter 116 – Control of Air Pollution by Permits For New Construction or Modification;
- Chapter 117 – Control of Air Pollution From Nitrogen Compounds;
- Chapter 118 – Control of Air Pollution Episodes; and
- Chapter 122 – Federal Operating Permits.

Golden Pass would comply with all applicable state requirements.

### **Pipeline Expansion**

The Pipeline Expansion includes the Calcasieu Loop, MP 33 Compressor Station, and MP 66 Compressor Station.

#### Federal Air Quality Requirements

**New Source Review/Prevention of Significant Deterioration.** The Calcasieu Loop, the MP 33 Compressor Station, and the MP 66 Compressor Station do not fall under a listed major stationary source category. The MP 66 and MP 33 Compressor Stations would not be considered major PSD sources because they would not exceed the 250-tpy threshold during operation. Although the MP 66 Compressor Station would exceed the de minimis GHG PSD threshold of 75,000 tpy CO<sub>2e</sub>, because the stationary source would not exceed the 250-tpy<sup>33</sup> PSD threshold for the other criteria pollutants, it would not be subject to the PSD permitting requirements in accordance with the EPA’s July 24, 2014 guidance memorandum (see footnotes 29 and 30). No air-pollutant-emitting equipment associated with the Calcasieu Loop could trigger a NSR or PSD permit. Table 4.11.1-4 lists major source emission thresholds, and table 4.11.1-7 summarizes the PTE from the equipment proposed for the MP 33 and MP 66 Compressor Stations.

To ensure that the required minor NSR permit for the MP 33 Compressor Station is obtained within 18 months of the start of construction, the anticipated date for filing an application with the TCEQ for this compressor station is first quarter of 2016. Golden Pass anticipates filing its minor NSR permit application for the MP 66 Compressor Station with the LDEQ in June 2017.

**New Source Performance Standards.** Based on the types of emission units and the expected date of installation, applicable NSPS for the MP 33 and MP 66 Compressor Stations potentially would include, but not be limited to, the following:

- 40 CFR 60 Subpart A – General Provisions. Subpart A contains the general requirements applicable to all emission units subject to 40 CFR 60.
- 40 CFR Subpart Kb – Standards of Performance for Volatile Organic Liquid Storage Vessels (including Petroleum Liquid Storage Vessels).
- 40 CFR 60 Subpart JJJ – Standards of Performance for Stationary SI ICEs.

---

<sup>33</sup> Per Golden Pass’ submittal of additional information on June 8, 2015 (re Update to Golden Pass’ July 7, 2014 Application) and September 25, 2015 Response to FERC Information Request dated September 10, 2015 (re Environmental and Engineering Data Request), PSD applicability to the MP 66 Compressor Station has been reevaluated and is now deemed subject to minor NSR rather than PSD major source review. The revised summary of potential emissions from MP 66 show the Project emission increases to be less than the 250-tpy major source threshold.

- 40 CFR 60 Subpart KKKK – Standards of Performance for Stationary Gas Turbines.
- 40 CFR 60 Subpart OOOO – Standards of Performance for Crude Oil and Natural Gas Production, Transmission and Distribution.

<b>TABLE 4.11.1-7</b>							
<b>Pipeline Expansion Potential-to-Emit</b>							
<b>Emission Unit (Quantity)</b>	<b>Pollutant Emissions (tpy)</b>						
	<b>NO<sub>x</sub></b>	<b>CO</b>	<b>SO<sub>2</sub></b>	<b>PM<sub>10</sub>/ PM<sub>2.5</sub></b>	<b>VOC</b>	<b>HAPs</b>	<b>GHG</b>
<b>MP 33 Compressor Station (Orange County, TX)</b>							
NG-fired compressors (2) and MSS emissions	44.1	45.6	0.2/0.1	13.2	5.6	0.7	85,848
NG essential generators (1 –100 hours/year)	0.1	0.3	<0.1	<0.1	<0.1	<0.1	10
Storage tanks (2)	--	--	--	--	0.1	--	--
Fugitive emissions (valves, flanges, compressors, vents)	--	--	--	--	0.2	--	580
Blowdown events (4)	--	--	--	--	0.1	--	213
Truck loading operations	--	--	--	--	0.0	--	--
<b>TOTAL (MP 33)</b>	<b>44.2</b>	<b>45.9</b>	<b>0.2/0.1</b>	<b>13.2</b>	<b>6.0</b>	<b>0.7</b>	<b>86,651</b>
<b>MP 66 Compressor Station (Calcasieu Parish, LA) <u>a</u></b>							
Natural gas-fired compressors (4 – 148.8 MMBtu/hr) and MSS emissions (5)	156.4	162.9	7.5	0.9/0.5	3.6	2.7	305,232
Natural Gas-Fired Compressors (2 – 83.7 MMBtu/hr) and MSS emissions (2)	44.0	45.6	2.1	0.2/0.1	1.0	0.7	85,883
NG Essential Generators (7 –100 hours/year)	1.0	2.2	0.0	0.0	<0.1	<0.1	68
Storage Tanks (2)	--	--	--	--	0.1	--	--
Fugitive Emissions (valves, flanges, compressors, vents)	--	--	--	--	<0.1	<0.1	30
Blowdown events (14)	--	--	--	--	3.4	0.0	2,772
Truck loading operations	--	--	--	--	0.8	<0.1	0
<b>TOTAL (MP 66)</b>	<b>201.4</b>	<b>210.7</b>	<b>9.6</b>	<b>1.1/0.6</b>	<b>8.9</b>	<b>3.4</b>	<b>393,985</b>
<u>Abbreviations:</u>							
NO <sub>x</sub> = oxides of nitrogen		CO = carbon monoxide					
SO <sub>2</sub> = sulfur dioxide		PM <sub>10</sub> = particulate matter less than 10 microns					
VOC = volatile organic compounds		HAPs = hazardous air pollutants					
tpy = tons per year		-- = no emissions data					
MSS = maintenance, startup, and shutdown							
GHG = greenhouse gas, as CO <sub>2</sub> equivalent (CO <sub>2</sub> -eq, including CO <sub>2</sub> , CH <sub>4</sub> , and N <sub>2</sub> O), rounded to whole numbers)							

**National Emissions Standards for Hazardous Air Pollutants.** The pipeline and compressor stations are not expected to include processes regulated by 40 CFR 61. Based on the types of emission units and the expected dates of installation, applicable NESHAPs for the Project potentially would include, but not be limited to, the following:

- 40 CFR 63 Subpart A – General Provisions. Subpart A contains the general requirements applicable to all emission units subject to 40 CFR 63.
- 40 CFR 63 Subpart ZZZZ – NESHAPs for Stationary RICE.

**Title V Operating Permit.** The EPA has delegated to the TCEQ and the LDEQ the authority to issue Title V permits. As shown in table 4.11.1-7, emissions from the MP 33 Compressor Stations would not exceed the Title V major source thresholds for any criteria pollutant; therefore, it would not be subject to the Title V permitting requirements. The MP 66 Compressor Station would exceed the Title V threshold of 100 tpy for the criteria pollutants NO<sub>x</sub> and CO. The MP 66 Compressor Station would be considered a Title V major source, and a Title V permit would be required for operation of the facility. Golden Pass anticipates filing its Title V operating permit application for the MP 66 Compressor Station with the LDEQ in June 2017.

**Greenhouse Gases Reporting Rule.** The MP 33 and MP 66 Compressor Stations would be subject to the GHG Mandatory Reporting Rule. As shown in table 4.11.1-7, the PTE for both stations would exceed the 25,000-mtpy CO<sub>2</sub>-eq GHG reporting threshold. The rule establishes reporting requirements based on actual emissions; however, it does not require emission controls. Golden Pass would need to monitor emissions in accordance with the reporting rule. If actual emissions exceed the 25,000 mtpy CO<sub>2</sub>-eq reporting threshold, Golden Pass would be required to report its GHG emissions to the EPA.

#### Applicable State Air Quality Requirements

The MP 33 Compressor Station would be subject to Texas state standards, codified in TAC Title 30, Part I (see similar applicability under Terminal Expansion and MP 1 Compressor Station above), except Chapter 122.

The Louisiana Administrative Code Title 33, Part III (LAC, 2014) regulations listed below would apply to the new emission units and fugitive emissions associated with the MP 66 Compressor Station:

- Chapter 9 – General Regulations on Control of Emissions and Emission Standards;
- Chapter 11 – Control of Emissions of Smoke;
- Chapter 13 – Emission Standards for Particulate Matter;
- Chapter 15 – Emission Standards for Sulfur Dioxide;
- Chapter 17 – Control of Emissions of Carbon Monoxide (New Sources);
- Chapter 21 – Control of Emission of Organic Compounds; and
- Chapter 51 – Comprehensive Toxic Air Pollutant Emission Control Program.

Golden Pass would comply with all applicable state requirements.

#### 4.11.1.4 Construction Air Emissions Impacts and Mitigation

##### Terminal Expansion

Emissions during construction generally would be associated with onshore activities and marine construction activities. Onshore construction emissions would be associated with on-road, off-road, and mobile equipment. Marine construction would be conducted using tugs and barges.

##### On-road, Off-road, and Mobile Equipment Emissions

Potential impacts on ambient air quality for construction projects typically include generation of fugitive dust and combustion emissions from construction equipment operation. Fugitive dust results from construction activities such as land clearing, grading, excavation, and concrete work, as well as from vehicles traveling on paved and unpaved roads. Fugitive dust generation depends on the area of construction, silt and moisture contents of the soil, wind speed, frequency of precipitation, amount of vehicle traffic, and vehicle and roadway type. Fugitive dust may be produced during all phases of construction. Emissions are typically greatest during drier winter months and in areas of fine-textured soils. The control of fugitive particulate emissions typically is addressed through compliance with state or local nuisance regulations. For the Terminal Expansion, Texas state regulations Sections 111.141 through 111.145 (Materials Handling, Construction, Roads, Streets, Alleys, and Parking Lots) would apply. Golden Pass would use dust suppression techniques, such as spraying water or dust suppressants to dampen the surfaces of dry work areas, in addition to the requirements in Texas state regulations for fugitive dust control. Table 4.11.1-8 provides a summary of fugitive emissions resulting from construction activities for the Terminal Expansion.

<b>TABLE 4.11.1-8</b>						
<b>Summary of Fugitive Emissions during Construction of the Terminal Expansion</b>						
<b>Disturbed Land Area <u>a</u> (acres)</b>	<b>Duration (months) <u>b</u></b>	<b>Control Efficiency <u>c</u> (%)</b>	<b>EF <u>d</u> (tons/ acre/ month)</b>	<b>TSP (tpy)</b>	<b>PM<sub>10</sub> <u>e</u> (tpy)</b>	<b>PM<sub>2.5</sub> <u>f</u> (tpy)</b>
919	55 months	50	1.2	4,726	1,277	147
<b>Abbreviations:</b>						
EF = emission factor			TSP= total suspended particulates			
tpy = tons per year			PM <sub>10</sub> = particulate matter less than 10 microns			
PM <sub>2.5</sub> = particulate matter less than 2.5 microns						
<b>Notes:</b>						
<b><u>a</u></b>	Disturbed land area means the total land area affected by construction activities related to development of the Terminal Expansion.					
<b><u>b</u></b>	Number of months that construction took place based on 5 days per week work schedule; emissions calculations were adjusted to account for this assumption (that is, used a factor of 5/7).					
<b><u>c</u></b>	Fugitive emissions calculations assume using dust suppressants (0.1 gallon/square yard per month) as a dust control measure corresponding to 50 percent control efficiency, per the EPA's AP-42 chapter 13 figure 13.2.2-5.					
<b><u>d</u></b>	Emission factor per EPA's AP-42 section 13.2.3.3, applicable to construction operations with: (1) medium activity level; (2) moderate silt contents; and (3) semiarid climate.					
<b><u>e</u></b>	PM <sub>10</sub> emission calculated based on adjustment factor of 27% of TSP, using the scaling factor of 0.60 for grading and multiplier for PM <sub>15</sub> in AP-42 table 11.9-1 and assumed speed of 8 mph.					
<b><u>f</u></b>	PM <sub>2.5</sub> emission calculated based on adjustment factor of 3.1% of TSP, using the scaling factor of 0.031 for grading and multiplier for TSP in AP-42 table 11.9-1 and assumed speed of 8 mph.					

Construction-related air quality impacts also are associated with operation of gasoline- or diesel-fueled engines in on-road, off-road, stationary, and mobile equipment. A summary of expected construction emissions and commuting emissions is provided in tables 4.11.1-9 and 4.11.1-10, respectively.

As with any fossil fuel-fired activity, construction equipment used for the Terminal Expansion would contribute GHG emissions, including CH<sub>4</sub>, CO<sub>2</sub>, and N<sub>2</sub>O. Emissions of GHGs typically are estimated as CO<sub>2</sub>-eq. Although the EPA's GHG Mandatory Reporting Rule does not apply to construction and commuting emissions, GHG emissions are included in tables 4.11.1-8 and 4.11.1-9 for accounting and disclosure purposes.

<b>TABLE 4.11.1-9</b>							
<b>Summary of Construction Equipment Emissions for the Terminal Expansion</b>							
Year	Annual Pollutant Emissions (tpy) <sup>a</sup>						
	NO <sub>x</sub>	CO	SO <sub>2</sub>	PM <sub>10</sub>	PM <sub>2.5</sub>	VOC	GHG
2016	91.8	300.5	0.3	6.5	6.2	15.0	26,946
2017	144.3	615.7	0.4	10.4	10.0	28.2	44,302
2018	133.6	723.2	0.4	9.4	9.0	29.7	43,598
2019	84.5	544.3	0.3	5.7	5.4	20.2	29,130
2020	24.5	174.6	0.1	1.6	1.5	5.9	6,830
<b>TOTAL (tons)</b>	<b>478.7</b>	<b>2,358.3</b>	<b>1.5</b>	<b>33.6</b>	<b>32.1</b>	<b>99.0</b>	<b>150,806</b>
<b>Abbreviations:</b>							
NO <sub>x</sub> = oxides of nitrogen				CO = carbon monoxide			
SO <sub>2</sub> = sulfur dioxide				PM <sub>10</sub> = particulate matter less than 10 microns			
VOC = volatile organic compounds				PM <sub>2.5</sub> = particulate matter less than 2.5 microns			
tpy = tons per year							
GHG = greenhouse gas, as CO <sub>2</sub> equivalent (CO <sub>2</sub> -eq, including CO <sub>2</sub> , CH <sub>4</sub> , and N <sub>2</sub> O) rounded to whole numbers							
<b>Note:</b>							
<b>a</b> Emissions were calculated using the EPA NONROAD model (EPA NONROAD2008).							

**TABLE 4.11.1-10**

**Summary of Commuting Emissions for the Terminal Expansion**

Year	Annual Pollutant Emissions (tpy) <u>a</u>						
	NO <sub>x</sub>	CO	SO <sub>2</sub>	PM <sub>10</sub>	PM <sub>2.5</sub>	VOC	GHG
2016	8.3	39.4	0.1	0.4	0.3	3.1	5,914
2017	45.0	214.4	0.6	2.3	1.7	16.7	32,192
2018	68.3	325.2	0.8	3.5	2.5	25.3	48,827
2019	45.2	215.1	0.6	2.3	1.7	16.7	32,284
2020	3.2	15.4	0.0	0.2	0.1	1.2	2,318
<b>TOTAL</b>	<b>170.0</b>	<b>809.5</b>	<b>2.1</b>	<b>8.8</b>	<b>6.3</b>	<b>62.9</b>	<b>121,535</b>

Abbreviations:

NO<sub>x</sub> = oxides of nitrogen

CO = carbon monoxide

SO<sub>2</sub> = sulfur dioxide

PM<sub>10</sub> = particulate matter less than 10 microns

VOC = volatile organic compounds

PM<sub>2.5</sub> = particulate matter less than 2.5 microns

tpy = tons per year

GHG = greenhouse gas, as CO<sub>2</sub> equivalent (CO<sub>2</sub>-eq, including CO<sub>2</sub>, CH<sub>4</sub>, and N<sub>2</sub>O) rounded to whole numbers)

Note:

**a** Emissions were calculated using the 2017 emission factors from the EPA MOVES (EPA Motor Vehicle Emission Simulator) modeling for the BPA area on-road emissions inventories for SIP submission and based on the following assumptions: (1) 140 miles round-trip commute per day per worker; (2) 20 miles round-trip bus service for offsite parking; and (3) the number of commuters based on assumptions for the workforce in section 4.9.1.

Marine Emissions

Criteria air pollutant emissions from marine operations also are expected during the construction period. The emissions would come from tugboats traveling to and from Beaumont, Houston, and Port Arthur, carrying materials and equipment needed for construction of the Project. Table 4.11.1-11 provides a summary of construction-related emissions for NO<sub>x</sub>, CO, SO<sub>2</sub>, PM<sub>10</sub>, PM<sub>2.5</sub>, VOC, and GHGs from marine operations according to year and area affected.

Mitigation Measures

Golden Pass' control measures to minimize fugitive dust from vehicle travel would meet all the TCEQ requirements for fugitive dust mitigation. These measures may include watering or applying dust suppressants to the disturbed construction area, washing construction equipment, and minimizing the area being disturbed to the extent possible during each phase of construction. Vehicular exhaust and crankcase emissions from gasoline and diesel engines would comply with applicable EPA mobile source emission regulations (40 CFR 85) by using equipment manufactured to meet these specifications.

The air emissions and fugitive dust that would occur during construction of the Terminal Expansion primarily would be limited to the immediate vicinities of the existing terminal site. These emissions would represent a small portion of the county's yearly emissions inventories and would subside once construction has been completed.

TABLE 4.11.1-11

## Summary of Marine Commuting Emissions

Area Affected	Year	Number of Trips	Annual Pollutant Emissions (tpy) <sup>a</sup>						
			NO <sub>x</sub>	CO	SO <sub>2</sub>	PM <sub>10</sub>	PM <sub>2.5</sub>	VOC	GHG
Beaumont (BPA)	2016	220	5.3	3.9	0.0	0.2	0.2	0.2	526
	2017	0	0.0	0.0	0.0	0.0	0.0	0.0	0.0
	2018	562	13.6	10.0	0.0	0.5	0.5	0.5	1,343
	2019	562	13.6	10.0	0.0	0.5	0.5	0.5	1,343
	2020	374	9.1	6.7	0.0	0.3	0.3	0.4	894
	2021 <sup>b</sup>	24	0.6	0.4	0.0	0.0	0.0	0.0	57
Port Arthur (BPA)	2016	640	4.3	3.1	0.0	0.2	0.2	0.2	421
	2017	620	4.1	3.0	0.0	0.2	0.2	0.2	409
	2018	80	0.5	0.4	0.0	0.0	0.0	0.0	53
	2019	0	0.0	0.0	0.0	0.0	0.0	0.0	0.0
	2020	0	0.0	0.0	0.0	0.0	0.0	0.0	0.0
	2021 <sup>b</sup>	24	0.1	0.0	0.0	0.0	0.0	0.0	16
Houston (BPA)	2016	0	0.0	0.0	0.0	0.0	0.0	0.0	0.0
	2017	0	0.0	0.0	0.0	0.0	0.0	0.0	0.0
	2018	62	2.9	2.2	0.0	0.1	0.1	0.1	289
	2019	62	2.9	2.2	0.0	0.1	0.1	0.1	289
	2020	42	2.0	1.5	0.0	0.1	0.1	0.1	196
<b>2016 – 2021 BPA Subtotal (tpy)</b>			<b>59.0</b>	<b>43.4</b>	<b>0.0</b>	<b>2.2</b>	<b>2.2</b>	<b>2.3</b>	<b>5,836</b>
Houston (HGB)	2016	0	0.0	0.0	0.0	0.0	0.0	0.0	0.0
	2017	0	0.0	0.0	0.0	0.0	0.0	0.0	0.0
	2018	62	1.4	1.0	0.0	0.1	0.1	0.1	140
	2019	62	1.4	1.0	0.0	0.1	0.1	0.1	140
	2020	42	1.0	0.7	0.0	0.0	0.0	0.0	95
<b>2016 – 2020 HGB Subtotal (tpy)</b>			<b>3.8</b>	<b>2.7</b>	<b>0.0</b>	<b>0.2</b>	<b>0.2</b>	<b>0.2</b>	<b>375</b>
<b>TOTAL (tons)</b>			<b>62.8</b>	<b>46.1</b>	<b>0.0</b>	<b>2.4</b>	<b>2.4</b>	<b>2.4</b>	<b>6,211</b>
<b>Abbreviations:</b>									
NO <sub>x</sub> = oxides of nitrogen					CO = carbon monoxide				
SO <sub>2</sub> = sulfur dioxide					PM <sub>10</sub> = particulate matter less than 10 microns				
VOC = volatile organic compounds					PM <sub>2.5</sub> = particulate matter less than 2.5 microns				
tpy = tons per year									
GHG = greenhouse gas, as CO <sub>2</sub> equivalent (CO <sub>2</sub> -eq, including CO <sub>2</sub> , CH <sub>4</sub> , and N <sub>2</sub> O) rounded to whole numbers)									
<b>Notes:</b>									
<b>a</b> Marine emissions were calculated using the EPA's "Current Methodologies in Preparing Mobile Source Port-Related Emission Inventories" and based on estimated distance, number of trips, and time per trip for each port (EPA, 2009).									
<b>b</b> Marine emissions in 2021 in the BPA area are related to construction demobilization efforts.									



## Pipeline Expansion

### On-road, Off-road, and Mobile Equipment Emissions

Construction of the Pipeline Expansion would affect air quality due to fugitive dust and combustion emissions from operation of gasoline- or diesel-fueled engines in on-road, off-road, stationary, and mobile equipment during construction of the pipeline and associated facilities. The control of fugitive particulate emissions typically is addressed through compliance with state or local nuisance regulations. In the case of the MP 1 and MP 33 Compressor Stations, Texas state regulations Sections 111.141 through 111.145 (Materials Handling, Construction, Roads, Streets, Alleys, and Parking Lots) would apply. For the Calcasieu Loop and the MP 66 Compressor Station, Louisiana state regulations Section 1305 (Control of Fugitive Emission of Particulate Matter) and Section 1311 (Emission Limits [particulate matter]) would apply. Golden Pass would use dust suppression techniques, such as spraying water or dust suppressants to dampen the surfaces of dry work areas, in addition to the requirements in Texas and Louisiana state regulations for fugitive dust control. Table 4.11.1-12 provides a summary of fugitive emissions resulting from construction activities for the Pipeline Expansion.

During construction of the pipeline, Golden Pass may use open burning as an option to dispose of cleared and removed timber and vegetation. Open burning would be conducted in accordance with the requirements of TAC Title 30 Environmental Quality, Part 1 TCEQ, Chapter III (Control of Air Pollution from Visible Emissions and Particulate Matter), Subchapter B (Outdoor Burning), Rule 111.219 (General Requirements for Allowable Outdoor Burning – Requirements 3, 4, 6, and 7) for open burning. Air emissions from open burning also would include NO<sub>x</sub> (9.8 tpy), CO (343.0 tpy), VOC (46.6 tpy), and CH<sub>4</sub> (14.0 tpy or 350 tpy in CO<sub>2</sub>-eq).

<b>TABLE 4.11.1-12</b>						
<b>Summary of Fugitive Emissions during Construction of the Pipeline Expansion</b>						
<b>Disturbed Land Area <u>a</u> (acres)</b>	<b>Duration (months) <u>b</u></b>	<b>Control Efficiency <u>c</u> (%)</b>	<b>EF <u>d</u> (tons/ acre/ month)</b>	<b>TSP (tpy)</b>	<b>PM<sub>10</sub> <u>e</u> (tpy)</b>	<b>PM<sub>2.5</sub> <u>f</u> (tpy)</b>
99	24 months	50	1.2	578 <u>g</u>	139	16
<b>Abbreviations:</b>						
EF = emission factor			TSP= total suspended particulates			
PM <sub>10</sub> = particulate matter less than 10 microns			PM <sub>2.5</sub> = particulate matter less than 2.5 microns			
tpy = tons per year						
<b>Notes:</b>						
<b><u>a</u></b>	Disturbed land area means the total land area affected by construction activities related to development of the Pipeline Expansion					
<b><u>b</u></b>	The number of months that construction took place was based on a 5-days-per-week work schedule; emissions calculations were adjusted to account for this assumption (i.e., used a factor of 5/7).					
<b><u>c</u></b>	Fugitive emissions calculations assume using dust suppressants (0.1 gallon/square yard per month) as a dust control measure corresponding to 50 percent control efficiency, per the EPA's AP-42 chapter 13 figure 13.2.2-5.					
<b><u>d</u></b>	Emission factor per the EPA's AP-42 section 13.2.3.3, applicable to construction operations with: (1) medium activity level; (2) moderate silt contents; and (3) semi-arid climate.					
<b><u>e</u></b>	PM <sub>10</sub> emission calculated based on adjustment factor of 27% of TSP, using the scaling factor of 0.60 for grading and multiplier for PM <sub>15</sub> in AP-42 table 11.9-1 and assumed speed of 8 mph.					
<b><u>f</u></b>	PM <sub>2.5</sub> emission calculated based on adjustment factor of 3.1% of TSP, using the scaling factor of 0.031 for grading and multiplier for TSP in AP-42 table 11.9-1 and assumed speed of 8 mph.					
<b><u>g</u></b>	TSP includes fugitive emissions of 41.7 tpy from open burning and 353 tpy from other fugitives sources during construction.					

Construction of the Pipeline Expansion would contribute GHG emissions, including CH<sub>4</sub>, CO<sub>2</sub>, and N<sub>2</sub>O. Although the EPA's GHG Mandatory Reporting Rule does not apply to construction emissions and commuting emissions, we have included these GHG emissions in tables 4.11.1-13 and 4.11.1-14 for accounting and disclosure purposes.

<b>TABLE 4.11.1-13</b>								
<b>Summary of Construction Equipment Emissions for the Pipeline Expansion <u>a</u></b>								
<b>Emission Source</b>	<b>Year</b>	<b>Annual Pollutant Emissions (tpy)</b>						
		<b>NO<sub>x</sub></b>	<b>CO</b>	<b>SO<sub>2</sub></b>	<b>PM<sub>10</sub></b>	<b>PM<sub>2.5</sub></b>	<b>VOC</b>	<b>GHG</b>
MP 1 Compressor Station	2017	1.1	1.2	0.0	0.1	0.1	0.2	350
MP 33 Compressor Station	2017	1.0	1.2	0.0	0.1	0.0	0.1	350
MP 66 Compressor Station	2017	1.7	1.7	0.0	0.1	0.1	0.3	531
Calcasieu Loop	2017	0.2	0.8	0.0	0.0	0.0	0.2	66
<b>2017 Subtotal (tpy)</b>		<b>4.0</b>	<b>4.9</b>	<b>0.0</b>	<b>0.3</b>	<b>0.2</b>	<b>0.8</b>	<b>1,297</b>
MP 1 Compressor Station	2018	0.4	0.7	0.0	0.1	0.1	0.1	165
MP 33 Compressor Station	2018	0.4	0.6	0.0	0.0	0.0	0.1	164
MP 66 Compressor Station	2018	2.7	3.6	0.0	0.2	0.2	0.5	972
Calcasieu Loop	2018	2.6	3.9	0.0	0.2	0.2	0.5	1,074
<b>2018 Subtotal (tpy)</b>		<b>6.1</b>	<b>8.8</b>	<b>0.0</b>	<b>0.5</b>	<b>0.5</b>	<b>1.2</b>	<b>2,375</b>
<b>TOTAL (tons)</b>		<b>10.1</b>	<b>13.7</b>	<b>0.0</b>	<b>0.8</b>	<b>0.7</b>	<b>2.0</b>	<b>3,672</b>
<b>Abbreviations:</b>								
NO <sub>x</sub> = oxides of nitrogen			CO = carbon monoxide					
SO <sub>2</sub> = sulfur dioxide			PM <sub>10</sub> = particulate matter less than 10 microns					
VOC = volatile organic compounds			PM <sub>2.5</sub> = particulate matter less than 2.5 microns					
tpy = tons per year								
GHG = greenhouse gas, as CO <sub>2</sub> equivalent (CO <sub>2</sub> -eq, including CO <sub>2</sub> , CH <sub>4</sub> , and N <sub>2</sub> O) rounded to whole numbers)								
<b>Note:</b>								
<b>a</b> Emissions were calculated using the EPA's NONROAD model (EPA NONROAD2008).								

**TABLE 4.11.1-14**

**Summary of Commuting Emissions for the Pipeline Expansion a**

Emission Source	Year	Annual Pollutant Emissions (tpy)						
		NO <sub>x</sub>	CO	SO <sub>2</sub>	PM <sub>10</sub>	PM <sub>2.5</sub>	VOC	GHG
MP 1 Compressor Station	2017	0.9	4.3	0.0	0.1	0.1	0.4	644
MP 33 Compressor Station	2017	0.9	4.3	0.0	0.0	0.0	0.3	644
MP 66 Compressor Station	2017	1.8	8.8	0.0	0.1	0.1	0.7	1,325
Calcasieu Loop	2017	1.1	5.3	0.0	0.1	0.0	0.4	793
<b>2017 Subtotal (tpy)</b>		<b>4.7</b>	<b>22.7</b>	<b>0.0</b>	<b>0.3</b>	<b>0.2</b>	<b>1.8</b>	<b>3,406</b>
MP 1 Compressor Station	2018	0.7	3.6	0.0	0.1	0.1	0.3	541
MP 33 Compressor Station	2018	0.7	3.6	0.0	0.0	0.0	0.3	540
MP 66 Compressor Station	2018	1.5	7.1	0.0	0.3	0.1	0.6	1,069
Calcasieu Loop	2018	5.7	27.2	0.1	0.2	0.2	2.1	4,089
<b>2018 Subtotal (tpy)</b>		<b>8.7</b>	<b>41.5</b>	<b>0.1</b>	<b>0.6</b>	<b>0.4</b>	<b>3.3</b>	<b>6,239</b>
<b>TOTAL (tons)</b>		<b>13.4</b>	<b>64.2</b>	<b>0.1</b>	<b>0.9</b>	<b>0.6</b>	<b>5.1</b>	<b>9,645</b>
<b>Abbreviations:</b>								
NO <sub>x</sub> = oxides of nitrogen			CO = carbon monoxide					
SO <sub>2</sub> = sulfur dioxide			PM <sub>10</sub> = particulate matter less than 10 microns					
VOC = volatile organic compounds			PM <sub>2.5</sub> = particulate matter less than 2.5 microns					
tpy = tons per year								
GHG = greenhouse gas, as CO <sub>2</sub> equivalent (CO <sub>2</sub> -eq, including CO <sub>2</sub> , CH <sub>4</sub> , and N <sub>2</sub> O) rounded to whole numbers)								
<b>Note:</b>								
<b>a</b> Emissions were calculated using the EPA's NONROAD model (EPA NONROAD2008).								

Mitigation Measures

We received comments from the EPA regarding construction emissions and mitigation measures, including the use of BMPs for PM<sub>10</sub> and fugitive dust control. While Golden Pass' mitigation measures generally would help to control fugitive dust, more detail is necessary given that Project construction would occur in several phases during a 5-year period. The EPA recommended the following measures (Fugitive Dust, Mobile and Stationary Source and Administrative) to be considered in developing a *Construction Emissions Mitigation Plan* in order to reduce impacts associated with emissions of particulate matter and other pollutants from construction-related activities:

- Fugitive dust source controls: the *Construction Emissions Mitigation Plan* includes these general commitments:
- Stabilize heavily used unpaved construction roads with a non-toxic soil stabilizer or soil weighting agent that would not result in loss of vegetation or increase other environmental impacts.
- During grading, use water, as necessary, on disturbed areas in construction sites to control visible plumes.
- Vehicle speed:
  - Limit speeds to 25 mph on stabilized unpaved roads as long as such speeds do not create visible dust emissions;
  - Limit speeds to 10 mph or less on unpaved areas within construction sites on unstabilized (and unpaved) roads; and
  - Post visible speed limit signs at construction site entrances.
- Inspect and wash construction equipment vehicle tires, as necessary, so they are free of dirt before entering paved roadways, if applicable.
- Provide gravel ramps of at least 20 feet in length at tire washing/cleaning stations, and ensure that construction vehicles exit construction sites through treated entrance roadways, unless an alternative route has been approved by appropriate lead agencies, if applicable.
- Use sandbags or equivalent effective measures to prevent runoff to roadways in construction areas adjacent to paved roadways. Ensure consistency with the Project's SWPPP, if such a plan is required for the Project.
- Sweep the first 500 feet of paved roads exiting construction sites, other unpaved roads en route from the construction site, or construction staging areas whenever dirt or runoff from construction activity is visible on paved roads, or at least twice daily (less during periods of precipitation).
- Stabilize disturbed soils (after active construction activities are completed) with a non-toxic soil stabilizer, soil weighting agent, or other approved soil stabilizing method.
- Cover or treat soil storage piles with appropriate dust suppressant compounds and disturbed areas that remain inactive for longer than 10 days. Provide vehicles (used to transport solid bulk material on public roadways and that have potential to cause visible emissions) with covers. Alternatively, sufficiently wet and load materials onto the trucks in a manner to provide at least 1 foot of freeboard.
- Use wind erosion control techniques (such as windbreaks, water, chemical dust suppressants, and/or vegetation) where soils are disturbed in construction, access and maintenance routes, and materials stock pile areas. Keep related windbreaks in place until the soil is stabilized or permanently covered with vegetation.
- Mobile and stationary source controls:
  - If practicable, lease new, clean equipment meeting the most stringent of applicable federal<sup>34</sup> or state standards. In general, commit to the best available emissions control technology. Tier 4 engines should be used for Project construction equipment to the maximum extent feasible.

---

<sup>34</sup> The EPA's website for non-road mobile sources is <http://www.epa.gov/nonroad/>.

- Where Tier 4 engines are not available, use construction diesel engines with a rating of 50 hp or higher that meet, at a minimum, the Tier 3 California Emission Standards for Off-Road Compression-Ignition Engines, unless such engines are not available.
- Where Tier 3 engines are not available for off-road equipment larger than 100 hp, use a Tier 2 engine, or an engine equipped with retrofit controls to reduce exhaust emissions of NO<sub>x</sub> and diesel particulate matter to no more than Tier 2 levels.
- Consider using electric vehicles, natural gas, biodiesel, or other alternative fuels during construction and operation phases to reduce the Project's criteria and greenhouse gas emissions.
- Plan construction scheduling to minimize vehicle trips.
- Limit idling of heavy equipment to less than 5 minutes and verify through unscheduled inspections.
- Maintain and tune engines per manufacturer's specifications to perform at California Air Resources Board and/or EPA certification levels, prevent tampering, and conduct unscheduled inspections to ensure these measures are followed.
- Administrative controls:
  - Develop a *Construction Traffic and Parking Management Plan* that maintains traffic flow, and plan construction to minimize vehicle trips.
  - Identify any sensitive receptors in the Project area, such as children, the elderly, and the infirm, and specify the means by which impacts on these populations will be minimized (e.g., locate construction equipment and staging zones away from sensitive receptors and building air intakes).
  - Include provisions for monitoring fugitive dust in the Fugitive Dust Control Plan and initiate increased mitigation measures to abate any visible dust plumes.

Specifically, more information regarding other mitigation measures for dust abatement in addition to spraying of water (e.g., reducing vehicle speeds where appropriate for travel on unpaved roads, using dust suppressants in high erosion areas to control dust in residential areas and near road crossings, and training of Project personnel) is necessary. In addition, Golden Pass has not provided any information about accountability or individuals with authority regarding fugitive dust mitigation. Therefore, **we recommend that:**

- **Prior to construction, Golden Pass should file with the Secretary, for review and approval by the Director of Office of Energy Projects (OEP), a *Fugitive Dust Control Plan* that specifies the precautions that Golden Pass would take to minimize fugitive dust emissions from construction activities, including additional mitigation measures recommended by the EPA to control particulate matter with an aerodynamic diameter less than or equal to 10 microns and 2.5 microns. The plan should clearly explain how Golden Pass would implement such measures as:**
  - a. **watering the construction workspace and access roads;**
  - b. **providing measures to limit track-out onto the roads;**
  - c. **identifying the speed limit that Golden Pass would enforce on unsurfaced roads;**
  - d. **covering open-bodied haul trucks, as appropriate;**

- e. **clarifying that the EI has the authority to determine if/when water or an alternative dust suppressant needs to be used for dust control; and**
- f. **clarifying the individuals with the authority to stop work if the contractor does not comply with dust control measures.**

Based on the analysis above and with implementation of our recommendation we conclude the Project's construction-related impacts on local air quality would not be significant.

#### **4.11.1.5 Operations Air Emissions Impacts and Mitigation**

##### **Terminal Expansion and MP 1 Compressor Station**

###### Emissions

Emissions during operation of the Terminal Expansion and MP 1 Compressor Station primarily would be associated with the equipment list shown in table 4.11.1-5. Pollutants that would be emitted include NO<sub>x</sub>, CO, GHG, SO<sub>2</sub>, PM<sub>2.5</sub>, PM<sub>10</sub>, and VOCs. Tables 4.11.1-3 and 4.11.1-5 list facility-wide emission summaries based on PTE from the existing and new emission units within the Golden Pass Terminal Site.<sup>35</sup>

Golden Pass conducted air dispersion modeling for compliance with PSD and the NAAQS for NO<sub>2</sub>, CO, PM<sub>10</sub>, and PM<sub>2.5</sub> for the Golden Pass Terminal Site. A screening analysis was conducted to determine whether emissions from the equipment listed in table 4.11.1-5 would cause a significant impact.

As shown in table 4.11.1-15, the screening results indicate that CO and PM<sub>2.5</sub> are below their respective PSD modeling significant impact levels (SILs); therefore, further modeling was not required. However, the 1-hour NO<sub>2</sub> exceeded the corresponding SIL; hence, a full impact (cumulative) analysis consisting of an NAAQS analysis was performed for 1-hour NO<sub>2</sub>. As shown in table 4.11.1-16, results of the full impact analysis indicate that the 1-hour NO<sub>2</sub> emissions would be less than the corresponding NAAQS and, therefore, would not contribute to a violation of the 1-hour NO<sub>2</sub> NAAQS.

---

<sup>35</sup> The Golden Pass Terminal Site includes the Terminal Expansion, existing terminal, and MP 1 Compressor Station (see footnote 31).

TABLE 4.11.1-15				
Significant Impact Analysis for Operation of the Golden Pass Terminal Site <u>a</u>				
Screening Results				
Pollutant and Averaging Period	Year	Maximum Modeled Concentration ( $\mu\text{g}/\text{m}^3$ )	SIL ( $\mu\text{g}/\text{m}^3$ )	Below SIL? (Yes or No)
CO 1-hour	2008-2012	1,501.5	2,000	Yes
CO 8-hour	2008-2012	367.7	500	Yes
NO <sub>2</sub> 1-hour	2008-2012	14.6	7.5	No
NO <sub>2</sub> Annual	2008-2012	0.9	1	Yes
PM <sub>10</sub> 24-hour	2008-2012	1.2	5	Yes
PM <sub>10</sub> Annual	2008-2012	0.2	1	Yes
PM <sub>2.5</sub> 24-hour	2008-2012	1.19	1.20	Yes
PM <sub>2.5</sub> Annual	2008-2012	0.2	0.3	Yes
<b>Abbreviations:</b> $\mu\text{g}/\text{m}^3$ = micrograms per cubic meter SIL = Significant Impact Level <b>Note:</b> <u>a</u> The Golden Pass Terminal Site includes the Terminal Expansion, existing terminal, and MP 1 Compressor Station (see footnote 31).				

TABLE 4.11.1-16				
NAAQS Full Impact Analysis for 1-hour NO <sub>2</sub> during Operation of the Golden Pass Terminal Site <u>a</u>				
Maximum Modeled NO <sub>2</sub> Concentration ( $\mu\text{g}/\text{m}^3$ )	Background NO <sub>2</sub> Concentration ( $\mu\text{g}/\text{m}^3$ )	Maximum Modeled plus Background Concentration ( $\mu\text{g}/\text{m}^3$ )	NAAQS ( $\mu\text{g}/\text{m}^3$ )	Below NAAQS?(Yes or No)
43.7	69.9	113.6	188.0	Yes
<b>Abbreviations:</b> $\mu\text{g}/\text{m}^3$ = micrograms per cubic meter NAAQS = National Ambient Air Quality Standards <b>Note:</b> <u>a</u> The Golden Pass Terminal Site includes the Terminal Expansion, existing terminal, and MP 1 Compressor Station (see footnote 31).				

Because NO<sub>x</sub> and VOC emissions, which are precursors to ozone emission, would exceed the 100-tpy threshold,<sup>36</sup> the Project's potential ozone impact was analyzed through comparison of the Project emissions with those of a similar project that performed a recent photochemical modeling study in the BPA

<sup>36</sup> Per note to 40 CFR 52.21(i)(5)(i)(f): No *de minimis* air quality level is provided for ozone. However, any net emissions increase of 100 tpy or more of VOC or NO<sub>x</sub> subject to PSD would be required to perform an ambient impact analysis, including gathering ambient air quality data.

area. The modeling analysis for the Sabine Pass LNG facility<sup>37</sup> in 2011 (which was accepted by the LDEQ and the EPA Region 6) was chosen as a representative model for the Project's ozone impact determination. The potential 8-hour ozone impact modeling of the proposed Sabine Pass facility emissions was conducted using the Comprehensive Air Quality Model with Extensions (CAMx) and the May 26 through July 1, 2006 ozone episode prepared for the LDEQ for the Baton Rouge ozone redesignation submittal. The project impacts were evaluated based on absolute basis<sup>38</sup> and the EPA-preferred relative response factor basis,<sup>39</sup> both at the monitor locations and areas removed from the monitors. The ozone impact of the Sabine Pass project was deemed insignificant (AG, 2011). As summarized in the Sabine Pass ozone impact analysis report:

“...On a relative basis at the ozone monitors the project impact is estimated to change the 8-hour design value by a maximum of 0.5 ppb for the Actual case, and 0.6 ppb at the Allowable case at the Sabine Pass monitor. The impacts at other monitors in the Beaumont/Port Arthur region showed impacts of 0.1 ppb to 0.3 ppb for the actual case and 0.1 to 0.5 ppb for the *Allowable* (*emphasis provided to indicate word correction*) case. On the relative basis at areas removed from the monitors the maximum impact of the model does not impact any areas by greater than 1 ppb either on-land or off-shore for either case.

Using the Region VI suggested absolute basis metrics, the project is estimated to impact on-land grid cells greater than 1.0 ppb at limited areas on four of the episode days. The project does not impact on-land grid cells greater than 2 ppb on any day of the analysis. Depending on the metric, the Project emissions are estimated to increase the metric in the Beaumont/Port Arthur area between 0.0 percent to 6.8 percent for the Actual case and between 0.0 percent and 8.3 percent for the Allowable case...”

Golden Pass has not provided a final report demonstrating whether the Sabine Pass Project is comparable/representative of the Terminal Expansion. If the Sabine Pass project is demonstrated to be comparable/representative of the Terminal Expansion and the potential emissions from Terminal Expansion are less than the potential emissions from the Sabine Pass project, a preliminary conclusion can be reached that the increase in regional ozone concentrations associated with the Golden Pass LNG Export Project would also be insignificant. In order, however, to support this preliminary conclusion and to disclose the ozone impacts associated with the operation of the liquefaction facilities at the expanded terminal, **we recommend that:**

- **Prior to the end of the draft EIS comment period, Golden Pass should file with the Secretary, for review and approval by the Director of OEP, a complete photochemical modeling study of the Terminal Expansion.**

#### Mitigation Measures

Golden Pass would minimize potential impacts on air quality caused by operation of the Terminal Expansion and MP 1 Compressor Station by adhering to applicable federal and state regulations and installing BACT to minimize emissions. As presented in Golden Pass' PSD permit application, the BACT analysis identifies all applicable control technologies based on control effectiveness. The strictest controls are evaluated first. If those are technically or economically infeasible, or if environmental effects are significant, then the next most stringent control technology is reviewed. The process continues until the

---

<sup>37</sup> Ozone Impact Analysis of the Proposed Cheniere Sabine Pass Liquefaction Facility, Prepared by Dennis McNally and Cyndi Loomis, Alpine Geophysics, LLC, March 24, 2011 (as provided in Appendix F to Golden Pass' Ozone Impact Assessment Report [Trinity Consultants], July 9, 2014).

<sup>38</sup> “Absolute basis” pertains to the absolute concentrations obtained from gridded model output used to examine unmonitored area concentrations (EPA, 2007).

<sup>39</sup> “Relative response factor basis” means taking the ratio of future to present predicted air quality and multiplying it times an “ambient” design value based on observations made at monitor locations (EPA, 2007).



BACT level being considered cannot be eliminated based on technical or economic considerations, energy, or environmental impacts. The following BACT are proposed for NO<sub>x</sub>, CO, VOC, PM<sub>10</sub>, PM<sub>2.5</sub>, and GHG emissions from equipment associated with the Terminal Expansion and MP 1 Compressor Station.

**BACT for Gas Turbines/Heating Recovery Steam Generators.** For NO<sub>x</sub>, selective catalytic reduction and dry low-NO<sub>x</sub> burners are proposed BACT on the gas turbines with an emission rate limited to 5 parts per million, volumetric dry (ppmvd) corrected to 15 percent oxygen (O<sub>2</sub>) based on a 24-hour average. For CO, post combustion catalytic oxidation was determined as BACT with an emission rate limited to 6 ppmvd corrected to 15 percent O<sub>2</sub> based on a 3-hour average. For VOC, good combustion practices and post combustion catalytic oxidation were determined as BACT, with an emission rate limited to 4 ppmvd corrected to 15 percent O<sub>2</sub> based on a 3-hour average, as well as good work practice standards. For PM (encompassing both PM<sub>10</sub> and PM<sub>2.5</sub>), good combustion and maintenance practices and the use of low PM-emitting gaseous fuels were determined as BACT for turbine emissions. For GHG, use of low-carbon fuels, turbine design, heat recovery steam generator design, steam generator design, and operational energy efficiency were determined as BACT for these units.

**BACT for Thermal Oxidizers.** Four thermal oxidizers would be installed to control vents from the acid gas removal unit and the H<sub>2</sub>S Scavenger unit. One of the thermal oxidizers also would be used to route VOC emissions from the terminal expansion condensate storage tank and truck loading operations. Low NO<sub>x</sub> burners and good combustion and operating practices, with emission rate limited to 0.13 pound of NO<sub>x</sub> per MMBtu are proposed as BACT for NO<sub>x</sub>. Good combustion, maintenance and work practice standards, and the use of only low PM-emitting gaseous fuels were determined as BACT for CO and PM. Design and operational energy efficiency measures were determined as BACT for the control of GHG emissions from the acid gas removal unit and thermal oxidizer.

**BACT for Flares.** Three flares would be installed at the Terminal Expansion: one LNG storage low-pressure smokeless flare where the inert gas during purging of an LNG carrier ship would be routed, and one wet and one dry gas ground flare to control maintenance, startup, and shutdown (MSS) emissions and emergency releases. For complete combustion of the flare gas, a flame is maintained at the flare tip whenever vent gas is routed to the flare. The applicable general control device and work practice requirements under 40 CFR 60.18 and good combustion practices were determined as BACT for the flares to minimize NO<sub>x</sub> and CO emissions. The BACT for GHG for the flares is use of a good flare design with appropriate instrumentation and control.

**BACT for Diesel and Natural Gas Essential Generators.** Six diesel essential generators at the Terminal Expansion and one natural gas essential generator at the MP 1 Compressor station would be installed to serve as stand-by generators. These generators are internal combustion engine unit that would be required to comply with the applicable work practice standards and NO<sub>x</sub>, CO, VOC, and PM emission standards in NSPS 40 CFR 60 Subpart IIII (for the diesel-fired engines) and 40 CFR Subpart JJJJ (for the natural gas-fired engine). In complying with NSPS Subparts IIII and JJJJ, the equipment would be in compliance with the requirements of 40 CFR 63 Subpart ZZZZ (NESHAPs). In addition to installation of turbochargers and after-coolers and good combustion practices, compliance with 40 CFR 60 Subparts IIII and JJJJ was determined as BACT for NO<sub>x</sub>, CO, VOC, PM<sub>10</sub>, and PM<sub>2.5</sub> emissions. Good combustion practices and limiting non-emergency operating hours were determined as GHG BACT for all diesel and natural gas essential generators.

**BACT for Auxiliary Boiler.** One gas-fired auxiliary boiler would be needed as support equipment for the Terminal Expansion operations. Low NO<sub>x</sub> burners and good combustion practices were determined as BACT for NO<sub>x</sub>, CO, VOC, PM<sub>10</sub>, and PM<sub>2.5</sub> emissions of this unit. In addition, emission rate also would be limited to 0.029 pound of NO<sub>x</sub> per MMBtu and 50 ppmvd of CO at 3 percent O<sub>2</sub>. Visible emissions from the boiler would be limited to less than 5 percent opacity. For GHG, use of low-carbon fuels, design

energy efficiency, and operational energy efficiency is the BACT for the control of GHG emissions from the auxiliary boiler.

**BACT for Storage Tanks (Condensate, Diesel, and Amine), Fugitive Emissions, and Blowdown Vent.** VOC emissions are highest during nighttime hours and tank loading. Use of internal floating roof (for condensate storage tanks only) and submerged fill pipes was determined as BACT for the tanks. VOC emissions from fugitive components (valves, flanges, compressors, vents) would be controlled through implementation of the TCEQ's Tier I BACT 28VHP Leak Detection and Repair Program with control effectiveness of 97 percent. Limiting blowdowns to two events per year per compressor was determined as BACT for blowdown vents. Implementation of the 28VHP Leak Detection and Repair Program was determined as BACT to minimize GHG emissions from piping fugitive leaks at the Terminal Expansion and MP 1 Compressor Station.

As a result of incorporation of BACT, we believe that air quality impacts during construction and operation of the Terminal Expansion and MP 1 Compressor Station would be minor.

### **Pipeline Expansion**

#### Emissions

The anticipated emissions during operation of the Pipeline Expansion would be from the MP 33 Compressor Station, MP 66 Compressor Station, and from pipeline maintenance activities. Emissions from the compressor stations would be primarily from the equipment list shown in table 4.11.1-6, along with corresponding PTEs for NO<sub>x</sub>, CO, GHG, SO<sub>2</sub>, VOC, HAP, PM<sub>2.5</sub>, and PM<sub>10</sub>. There also would be fugitive emissions during operation of the compressor stations.

Golden Pass conducted air quality dispersion modeling for compliance with the NAAQS (see table 4.11.1-1) for NO<sub>2</sub>, CO, PM<sub>10</sub>, and PM<sub>2.5</sub> for the MP 66 Compressor Station. A Significant Impact Analysis was conducted to determine if emissions from the equipment listed above would cause a significant impact. The Significant Impact Analysis results are compared with each criteria pollutant's SIL to determine whether emissions from the facility would cause a significant impact. If results of this screening analysis indicate exceedance in SIL of any criteria pollutant, the area of impact is determined for full impact analysis (NAAQS and PSD increment models) for the pollutant in question (LDEQ, 2006).

As shown in table 4.11.1-17, the Significant Impact Analysis results indicate that CO, PM<sub>10</sub>, and PM<sub>2.5</sub> emissions from the MP 66 Compressor Station would be below their respective SILs. However, NO<sub>2</sub> was greater than the SIL; therefore, a full impact (cumulative) analysis was conducted for the 1-hour and annual NO<sub>2</sub>.

The area of impact analysis results indicate that the farthest significant receptors for the 1-hour and annual NO<sub>2</sub> averaging periods were 2,963.9 meters and 402.2 meters from the facility center, respectively. The radius of the circle covering off-property inventory sources from the facility center point is determined by adding 10 kilometers to the 1-hour NO<sub>2</sub> farthest significant receptors distance and adding 50 kilometers to the annual NO<sub>2</sub> farthest significant receptors distance (LDEQ, 2006). Therefore, the modeled concentrations for cumulative impacts analysis were taken at 12,963.9 and 50,402 meters from the center of the facility, for the 1-hour and annual NO<sub>2</sub> averaging periods, respectively.

**TABLE 4.11.1-17**

**Significant Impact Analysis for Operation of the MP 66 Compressor Station**

<b>Screening Results</b>				
<b>Pollutant and Averaging Period</b>	<b>Year</b>	<b>Modeled Concentration (µg/m<sup>3</sup>)</b>	<b>SIL (µg/m<sup>3</sup>) <sup>a</sup></b>	<b>Below SIL? (Yes or No)</b>
CO 1-hour	2009–2013	208.3	2,000	Yes
CO 8-hour	2009–2013	161.4	500	Yes
NO <sub>2</sub> 1-hour	2009–2013	1,344 <sup>b</sup>	7.5 <sup>d</sup>	No
NO <sub>2</sub> annual	2009–2013	5.9 <sup>c</sup>	1	No
PM <sub>10</sub> 24-hour	2009–2013	0.9	5	Yes
PM <sub>10</sub> annual	2009–2013	0.04	1	Yes
PM <sub>2.5</sub> 24-hour	2009–2013	0.6	1.20	Yes
PM <sub>2.5</sub> annual	2009–2013	0.03	0.3	Yes

**Abbreviations:**  
 µg/m<sup>3</sup> = micrograms per cubic meter  
 SIL = Significant Impact Level

**Notes:**

**a** The Class II SIL values for CO, NO<sub>2</sub> (annual), PM<sub>10</sub>, and PM<sub>2.5</sub> are found in 40 CFR 51.165(b)(2).  
**b** The 1-hour NO<sub>2</sub> modeled concentrations were multiplied by the default ambient ratio 0.80 (EPA, 2011b).  
**c** The annual NO<sub>2</sub> modeled concentrations were multiplied by the default ambient ratio 0.75 (EPA, 2011b).  
**d** The 1-hour NO<sub>2</sub> Class II SIL is based on the EPA's "General Guidance for Implementation of the 1-hour NO<sub>2</sub> NAAQS in Prevention of Significant Deterioration Permits, Including an Interim 1-hour NO<sub>2</sub> Significant Impact Level," June 28, 2010 (EPA, 2010).

As shown in table 4.11.1-18, results of the full impact analysis indicate that the 1-hour and annual NO<sub>2</sub> emissions would be less than the corresponding NAAQS; therefore, they would not contribute to a violation of the 1-hour or annual NO<sub>2</sub> NAAQS.

Mitigation Measures

Golden Pass anticipates filing their minor NSR permit application for the MP 33 Compressor Station in the first quarter of 2016 to ensure that the required permit would be obtained within 18 months of construction, as required by the TCEQ air permitting regulations. Golden Pass anticipates filing its minor NSR permit and Title V operating permit application for the MP 66 Compressor Station with the LDEQ in June 2017. It is expected that compliance with the applicable federal and state air quality standards and regulations would be addressed accordingly in the corresponding permit applications and issued permits. As a result, we believe that air quality impacts during operation of the MP 33 Compressor Station and the MP 66 Compressor Station would be minor.

**TABLE 4.11.1-18**

**NAAQS Full Impact Analysis for 1-hour NO<sub>2</sub> and Annual NO<sub>2</sub>  
for Operation of the MP 66 Compressor Station**

<b>Pollutant and Averaging Period</b>	<b>Year</b>	<b>Modeled NO<sub>2</sub> Concentration (µg/m<sup>3</sup>)</b>	<b>Tier 2 Adjusted Modeled NO<sub>2</sub> Concentration (µg/m<sup>3</sup>)</b>	<b>Background NO<sub>2</sub> Concentration (µg/m<sup>3</sup>) <sup>a</sup></b>	<b>Combined (Adjusted + Background) Concentration (µg/m<sup>3</sup>)</b>	<b>NAAQS (µg/m<sup>3</sup>)</b>	<b>Below NAAQS? (Yes or No)</b>
NO <sub>2</sub> 1-hour	2011–2013	154.5	123.6 <sup>b</sup>	45.7	169.3	188	Yes
NO <sub>2</sub> Annual	2011–2013	22.0	16.5 <sup>c</sup>	6.4	22.9	100	Yes

**Abbreviations:**  
 µg/m<sup>3</sup> = micrograms per cubic meter  
 NAAQS = National Ambient Air Quality Standards

**Notes:**  
<sup>a</sup> NO<sub>2</sub> background concentrations data were obtained from Hamshire, Texas monitoring station.  
<sup>b</sup> The Tier 2 adjusted 1-hour NO<sub>2</sub> modeled concentration was calculated by multiplying the modeled NO<sub>2</sub> concentration (Tier 1) by the default ambient ratio 0.80 (EPA, 2011b).  
<sup>c</sup> The Tier 2 adjusted annual NO<sub>2</sub> modeled concentration was calculated by multiplying the modeled NO<sub>2</sub> concentration (Tier 1) by the default ambient ratio 0.75 (EPA, 2011b).

**4.11.2 Noise**

**4.11.2.1 Noise Levels and Terminology**

Sound is mechanical energy transmitted by pressure waves in media such as air or water (FTA, 2006). When sound becomes excessive, annoying, or unwanted, it is referred to as noise. Noise may be continuous (constant noise with a steady decibel level), steady (constant noise with a fluctuating decibel level), impulsive (having a high peak of short duration), stationary (occurring from a fixed source), intermittent (at intervals of high and low sound levels), or transient (occurring at different rates).

Noise levels are quantified using decibels (dB), which are units of sound pressure. The A-weighted sound level, expressed as dBA, can be used to quantify sound and its effect on people (EPA, 1978). The A-weighted sound level is based on the dB unit but puts more emphasis on frequencies in the range that humans hear best and less emphasis on frequencies that humans do not hear well, thus mimicking the human ear. Other weighting scales exist (e.g., B, C, D, E, and G) but the EPA recommends the A-weighting scale as it is convenient and widely used. On the dBA scale, normal conversation falls at about 60 to 65 dBA, and sleep disturbance occurs at about 40 to 45 dBA.

Ambient sound levels, or background sound levels, result from sound emanating from natural and artificial sources. The magnitude and frequency of background noise may vary considerably over the course of a day and throughout the year, caused in part by weather conditions, seasonal vegetative cover, and human activity. Two measures used by federal agencies to relate the time-varying quality of environmental sound levels to known effects on people are the 24-hour equivalent sound level (L<sub>eq(24)</sub>) and the day-night sound level (L<sub>dn</sub>). The L<sub>eq(24)</sub> is the level of steady sound with the same total energy as the time-varying sound, averaged over a 24-hour period. The L<sub>dn</sub> is the L<sub>eq(24)</sub> with 10 decibels on the A-weighted decibel scale (dBA) added to the nighttime sound levels between the hours of 10 p.m. and 7 a.m. to account for people’s greater sensitivity to sound during nighttime hours.

Table 4.11.2-1 contains examples of common activities and their associated noise levels in dBA (Caltrans, 2009). Table 4.11.2-2 shows examples of outdoor day-night noise levels (EPA, 1978; Caswell and Jakus, 1977).

<b>TABLE 4.11.2-1</b>	
<b>Noise Levels of Common Activities</b>	
<b>Activity</b>	<b>Noise Level (dBA)</b>
Loud live band music	110
Truck 50 feet away	80
Gas lawnmower 100 feet away	70
Normal conversation indoors	60
Moderate rainfall on vegetation	50
Refrigerator	40
Bedroom at night	25
Source: Caltrans, 2009	
Abbreviation:	
dBA = A-weighted decibel	

<b>TABLE 4.11.2-2</b>	
<b>Examples of Outdoor Noise Levels</b>	
<b>Outdoor Location</b>	<b>Noise Levels (L<sub>dn</sub> in dBA)</b>
Apartment next to freeway	87.5
¾ mile from touchdown at major airport	86.0
Downtown with some construction activity	78.5
Urban high-density apartment	78.0
Core commercial, heavier industry	75.0
Heavier industry	75.0
Urban row housing on major avenue	68.0
Lighter industry	60.0
Old urban residential area	59.0
Wooded residential	51.0
Agricultural crop land	44.0
Rural residential	39.0
Open space (wetland, forest, open land, abandoned land)	35.0
Sources: EPA, 1978; Caswell and Jakus, 1977	
Abbreviations:	
dBA = A-weighted decibel	
L <sub>dn</sub> = Day-night sound level, expressed in dBA	

The potential for noise impacts can be assessed by considering the sound level increase over existing levels at receptors, referred to as “noise-sensitive areas” or “NSAs,” such as residences, schools, or hospitals. In general, an increase of 3 dBA is barely detectable by the human ear, and an increase of 5

dBA is considered clearly noticeable. Increases of 10 dBA are perceived as a doubling of noise or twice as loud.

During construction and operation, sound levels would increase in the vicinity of the Terminal Expansion site and the Pipeline Expansion areas. The EPA indicated that an  $L_{dn}$  of 55 dBA protects the public from indoor and outdoor activity interference. We have adopted this criterion and use it to evaluate the potential noise impacts from construction and operation of the Project. An  $L_{dn}$  of 55 dBA is equivalent to a continuous sound level of 48.6 dBA  $L_{eq}$  for facilities that generate constant sound levels.

#### **4.11.2.2 Noise Regulations**

For this study, the following facilities have been evaluated for noise impacts: (1) the Terminal Expansion site; (2) the MP 1 Compressor Station; (3) the MP 33 Compressor Station; (4) the MP 66 Compressor Station; and (5) HDD operations to install a portion of the Calcasieu Loop. The Terminal Expansion and MP 1 Compressor Station would be in the City of Port Arthur (Jefferson County), Texas; the MP 33 Compressor Station would be in Orange County, Texas; the MP 66 Compressor Station and the HDD-installed Calcasieu Loop pipeline section would be in Calcasieu Parish, Louisiana

The City of Port Arthur noise standard limits noise according to zoning district (e.g., residential, commercial, industrial) (Code of Ordinances, Chapter 34, Article V – Noise Control). The Terminal Expansion and MP 1 Compressor Station would be in an industrial zone. The NSAs are in residential zones. The applicable City of Port Arthur noise standard for the NSAs would limit Project-generated noise to no greater than 57 dBA during the day (7 a.m. to 10 p.m.) and 52 dBA at night (10 p.m. to 7 a.m.). Construction-related noise is exempt from this standard provided that such activities do not take place during nighttime hours (MCC, 2014a). These noise standards are above the FERC noise criteria of 55 dBA  $L_{dn}$  and 48.6 dBA  $L_{eq}$ .

No state or local noise level limits would apply to the MP 33 Compressor Station, which would be located in Orange County, Texas.

The Calcasieu Parish noise ordinance (Code of Ordinances, Chapter 18, Article VIII – Disturbing the Peace) does not set specific sound level limits but rather restricts excessive noise as follows: “No person shall make, continue, or cause to be made or continued any loud, unnecessary or excessive noise which unreasonably interferes with the comfort and repose of others within the jurisdiction of the parish” (Sec 18-96) (MCC, 2014b). Applicable exemptions include the following.

- Sec 18-99, paragraph (3) “Noises made by persons having obtained a permit.”
- Sec 18-99, paragraph (4) “Any noise resulting from activities of temporary duration, for which a permit has been granted pursuant to this article, and which conforms to the conditions and limits stated thereon.”
- Sec 18-100, paragraph (4) “Construction and demolition. The operating of any equipment used in construction work within 165 feet of any residential or noise sensitive area between sunset and sunrise on weekdays and Saturdays, and 9:00 p.m. and 8:00 a.m. on Sundays and holidays, except for emergency work.”

Absent an applicable state or local noise level limit and the fact that the City of Port Arthur noise level limits are above the FERC noise criteria, the more stringent FERC noise criterion of 55 dBA was used to evaluate the Project’s compliance with noise regulatory requirements.

### **4.11.2.3 Existing Noise Levels and Noise-sensitive Areas**

Golden Pass evaluated potential noise impacts during construction and operation of the Project by conducting a background noise level survey and noise impact evaluation at the nearest NSAs.

#### **Terminal Expansion**

A baseline noise survey was conducted on January 30 and 31, 2014, for the Terminal Expansion. Five residential NSAs were identified for the Terminal Expansion, where ambient noise levels were recorded. See figure 4.11.2-1. The primary sources of sound generation during the sound measurements included distant traffic noise and surrounding vegetation noise due to wind. The existing terminal was not in operation when these measurements were taken. Import activities at the existing terminal would not be operated simultaneously with export operations at the Terminal Expansion and MP 1 Compressor Station; therefore, these ambient noise survey results are representative levels for predicting Project-related noise impacts at the NSAs. Based on this survey, the ambient  $L_{dn}$  noise levels at the NSAs were estimated at 48.0 to 50.9 dBA. Table 4.11.2-3 shows the ambient noise survey results and estimated  $L_{dn}$  noise level at each NSA, as well as corresponding distances and directions from the Terminal Expansion.

#### **Pipeline Expansion**

##### **MP 1 Compressor Station**

The MP 1 Compressor Station would be in the same vicinity as the Terminal Expansion. The same five NSAs for the Terminal Expansion were identified as NSAs for the MP 1 Compressor Station (see figure 4.11.2-1); therefore, ambient noise levels were measured for the same NSAs as recorded for the Terminal Expansion. The distances from these residences to the MP 1 Compressor Station differ from their distances to the Terminal Expansion, as shown in table 4.11.2-3.





TABLE 4.11.2-3

Existing Noise Levels at NSAs for the Golden Pass LNG Export Project

Project Noise Source/NSA	NSA Land Use Type	NSA Distance and Direction from Project Noise Source	Existing Ambient Noise Levels, $L_{eq}$ (dBA)	Estimated $L_{dn}$ Noise Level (dBA)
<b>Terminal Expansion</b>				
NSA 1	Residential	7,875 feet SE	44.4 – 44.9	50.9
NSA 2	Residential	6,235 feet SW	40.0 – 44.5	48.0
NSA 3	Residential	6,560 feet W	40.6 – 45.5	48.8
NSA 4	Residential	6,560 feet NW	39.1 – 46.3	48.6
NSA 5 <u>a</u>	Residential	3,280 feet NE	39.3 – 47.3	49.3
<b>MP 1 Compressor Station</b>				
NSA 1	Residential	14,000 feet SE	44.4 – 44.9	50.9
NSA 2	Residential	3,470 feet SSW	40.0 – 44.5	48.0
NSA 3 <u>a</u>	Residential	2,030 feet W	40.6 – 45.5	48.8
NSA 4	Residential	4,720 feet N	39.1 – 46.3	48.6
NSA 5	Residential	7,160 feet NE	39.3 – 47.3	49.3
<b>MP 33 Compressor Station</b>				
NSA 1 <u>a</u>	Residential	1,150 feet NE	41.7	48.1
NSA 2	Residential	1,260 feet E	49.7	56.1
NSA 3	Residential	3,470 feet N	38.5	44.9
<b>MP 66 Compressor Station</b>				
NSA 1	Residential	7,680 feet SW	43.7	50.1
NSA 2	Residential	7,450 feet SSE	42.0	48.4
NSA 3 <u>a, b</u>	Residential	2,780 feet E	NM <u>b</u>	45.0 <u>b</u>
<b>Calcasieu Loop – HDD Entry</b>				
NSA 1	Residential	8,350 feet SW	NM <u>c</u>	45.0 <u>c</u>
NSA 2	Residential	7,200 feet SE	NM <u>c</u>	45.0 <u>c</u>
NSA 3 <u>b</u>	Residential	2,433 feet NE	NM <u>c</u>	45.0 <u>c</u>
<b>Calcasieu Loop – HDD Exit</b>				
NSA 1	Residential	7,150 feet ENE	NM <u>c</u>	45.0 <u>c</u>
NSA 2 <u>a</u>	Residential	3,250 feet SE	NM <u>c</u>	45.0 <u>c</u>
NSA 3	Residential	5,814 feet NE	NM <u>c</u>	45.0 <u>c</u>

Sources: CB&I, 2014; H&K, 2014a, 2014b, 2014c, 2014d

Abbreviations:

dBA = A-weighted decibel                      E = East                      N = North  
 NM = Not measured                              W = West                      S = South

Notes:

- a        The nearest NSA was used to estimate the worst-case construction noise impact.
- b        NSA 3 represents the nearest NSA to the MP 66 Compressor Station found on Google Map search after the September 2014 noise survey was conducted. Ambient noise level was not measured at this site but assumed a conservative  $L_{dn}$  noise level of 45.0 dBA.
- c        Ambient noise levels were not measured because of the NSA's remote location, but an  $L_{dn}$  noise level of 45.0 dBA was assumed.

### MP 33 Compressor Station

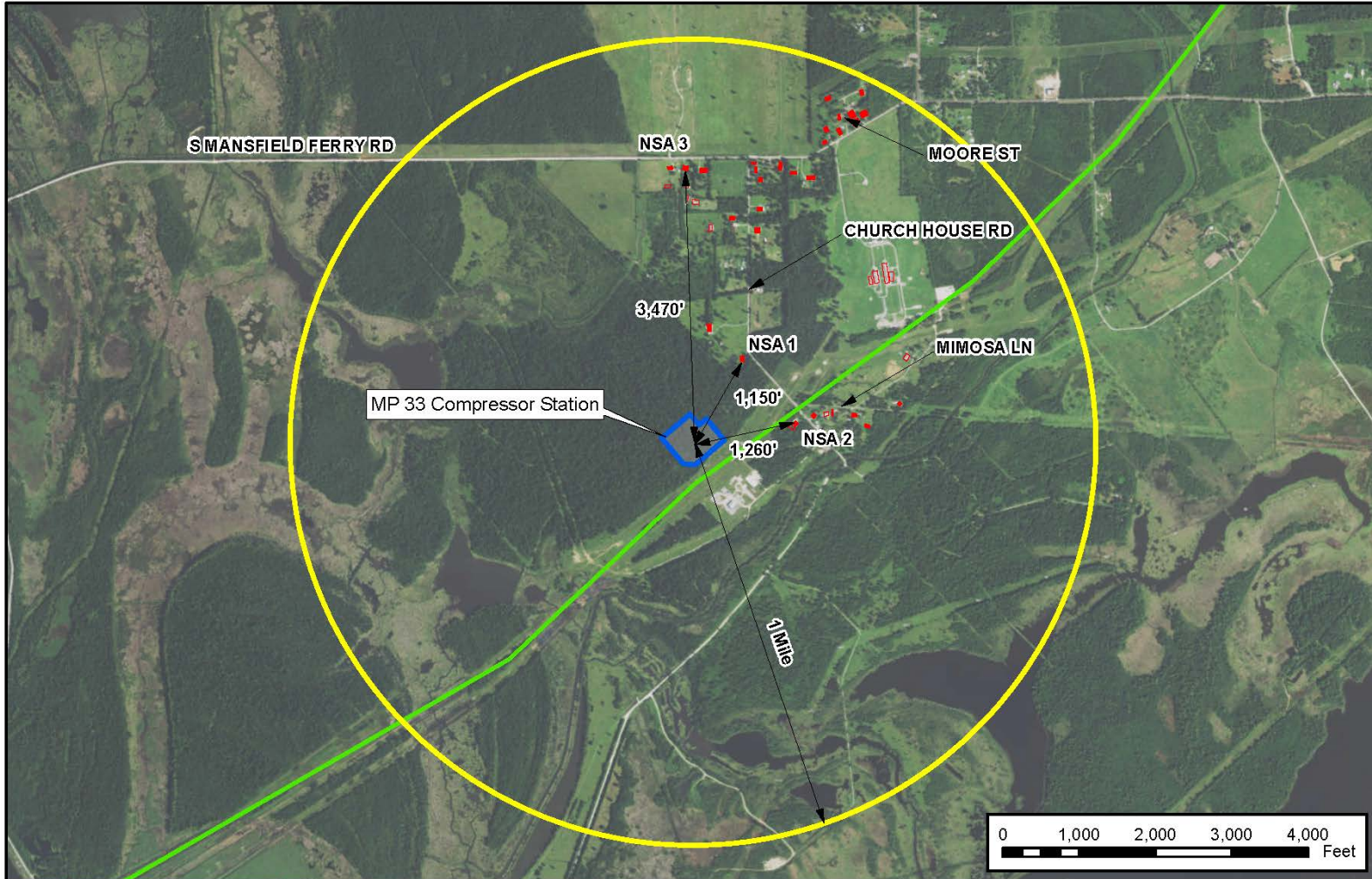
A baseline noise survey was conducted on September 24, 2013, for the MP 33 Compressor Station. Three residential NSAs were identified for the MP 33 Compressor Station, where ambient noise levels were recorded (see figure 4.11.2-2). The primary sources of sound generation during the sound measurements included natural sound of birds, insects and trees; distant traffic noise; and a house air conditioning unit that was in operation. The existing ambient  $L_{eq}$  noise levels for the NSAs recorded from the survey range from 38.5 to 49.7 dBA, with corresponding  $L_{dn}$  noise from 44.9 to 56.1 dBA, respectively. Table 4.11.2-3 shows the existing ambient noise survey results and estimated  $L_{dn}$  from each NSA, as well as corresponding distances and directions from the MP 33 Compressor Station.

### MP 66 Compressor Station

A baseline noise survey also was conducted on September 24, 2013, for the MP 66 Compressor Station. Two residential NSAs were identified for the MP 66 Compressor Station, where ambient noise levels were recorded (see figure 4.11.2-3). The primary sources of sound generation during the sound measurements included natural sound of birds, insects and trees; distant traffic noise; and a house air conditioning unit that was in operation. The existing ambient  $L_{eq}$  noise levels for these two NSAs were 43.7 and 42.0 dBA, with corresponding  $L_{dn}$  noise of 50.1 and 48.4 dBA, respectively. After the September 2013 survey, several structures east of the MP 66 Compressor Station were found through Google Earth search. To present a more accurate noise assessment, the additional structures are included here as a third NSA, with an approximate distance of 2,780 feet and an assumed conservative  $L_{dn}$  of 45 dBA. Table 4.11.2-3 shows the ambient noise levels from each NSA and their corresponding distances and directions from the MP 66 Compressor Station.

### Calcasieu Loop Pipeline Section

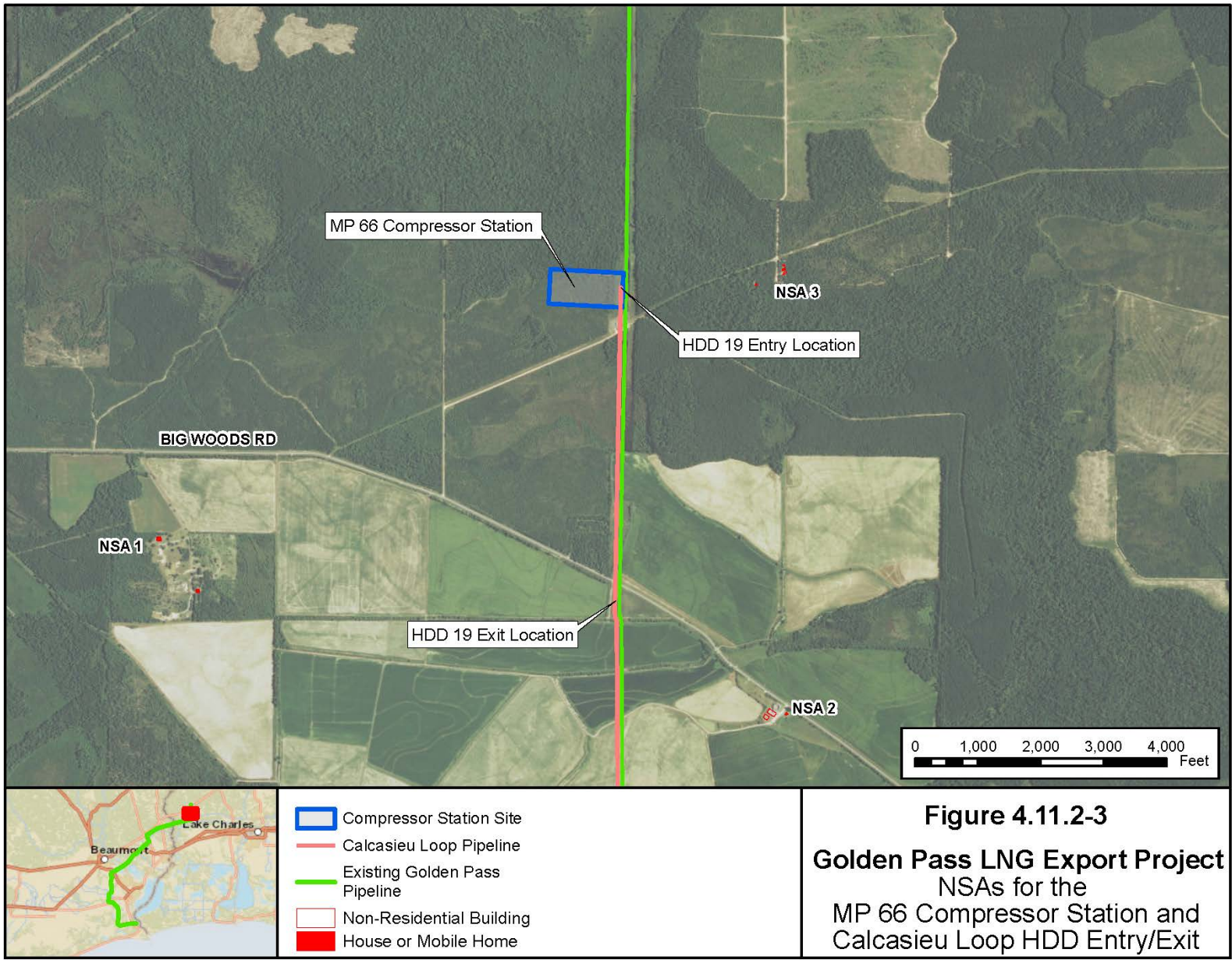
Golden Pass would use the HDD method to install a portion of the Calcasieu Loop pipeline. The HDD entry point would be near the MP 66 Compressor Station and the exit point south of Starks Big Woods Road. The total length of the pipeline section would be 4,800 feet. Because of its remote location, the existing ambient noise at the HDD-installed portions of the Calcasieu Loop was not recorded. For purposes of this study, a noise level of 45 dBA  $L_{dn}$  was assumed for these locations, which is comparable to the ambient noise level of an agricultural crop land (44 dBA [see table 4.11.2-2]). The same three NSAs were identified for the HDD operations as for the MP 66 Compressor Station (see figure 4.11.2-3 and table 4.11.2-3). The HDD operations would take place for about 4 months. The distances from these residences to the HDD entry and exit points differ from their distances to Compressor Station 66, as shown in table 4.11.2-3.



- Compressor Station Site
- Existing Golden Pass Pipeline
- Non-Residential Building
- House or Mobile Home
- One-Mile Radius

**Figure 4.11.2-2**  
**Golden Pass LNG Export Project**  
NSAs for the  
MP 33 Compressor Station





#### 4.11.2.4 Construction Noise Impacts and Mitigation

Construction noise levels are rarely steady; they fluctuate depending on the number and type of equipment in use at any given time. At times, no large equipment would be operating, and noise would be at or near existing ambient levels. In addition, construction-related sound levels experienced by a noise-sensitive receptor in the vicinity of construction activity would be a function of distance, other noise sources, and the presence and extent of vegetation and intervening topography between the noise source and the sensitive receptor.

##### Terminal Expansion

Construction of the Terminal Expansion would take place for about 45 months. Site preparation, civil works, and electrical and mechanical installation are the three main stages of construction considered in the noise modeling performed for the Terminal Expansion (CB&I, 2014).

- Site preparation would involve earthwork such as site clearing and fill.
- Civil works would include installation of foundation structures and the Supply Dock, and construction of onsite roads.
- Electrical and mechanical erection and installation noise includes noise from various steel works; noise from modifications to the existing terminal; tugs and barges used to receive and transport construction materials, heavy equipment, and plant modules; and installation and connection assembly of modules.

These activities would require operation of noise-producing heavy construction equipment and power generation units. The most prevalent sound-generating equipment during construction of the Terminal Expansion would be from pile driving and motor grader sound power levels<sup>40</sup> (PWL) up to 123 and 115 dBA, respectively. The sound levels experienced at the NSAs would depend on the type of equipment used, the mode of operation of the equipment, the length of time the equipment is in use, the amount of equipment used simultaneously, and the distance between the sound generation source and the receptor. The nearest NSA is NSA 5, located 3,280 feet from the Project site. The resulting noise level at NSA 5 is achieved by logarithmically adding the estimated noise level at the NSA location from each source for each construction month (CB&I, 2014). This assumes that equipment operations, including but not limited to pile driving, generally occur only during daytime hours (7:00 a.m.–10:00 p.m.). If necessary, any nighttime (10:00 p.m.–7:00 a.m.) construction-related work would involve transportation of materials to and from the jobsite, intermittent activities such as unloading of modules from vessels arriving at night, completing a concrete pour, or limited preparatory work for the following day.

CB&I conducted a noise impact modeling analysis using SoundPLAN noise modeling software Version 7.3. The analysis indicated that noise level increase due to construction activities at the Terminal Expansion would not exceed our noise criterion (an  $L_{dn}$  of 55 dBA noise at NSAs), as shown in table 4.11.2-4, and construction-related noise levels are not expected to result in adverse impacts on NSAs. Increases in sound levels during construction activities would be intermittent and generally would occur during daylight hours. However, certain activities may need to be conducted during non-daylight hours to avoid construction schedule delays, including unloading/staging of materials and barge unloading. Table 4.11.2-4 shows the predicted noise levels at the NSAs during construction of the Terminal Expansion.

---

<sup>40</sup> Sound power is a property of the source and remains independent of the factors influencing sound pressure (Caltrans, 2009). The PWL of an object is the amount of sound power it is capable of radiating; it is based on the specific object and does not take into account its surroundings.

<b>TABLE 4.11.2-4</b>					
<b>Noise Levels during Construction of the Terminal Expansion</b>					
<b>NSA</b>	<b>Distance and Direction</b>	<b>Sound Levels (dBA)</b>			<b>Change in Background Sound Level (dBA)</b>
		<b>Background (L<sub>dn</sub>)</b>	<b>Noise Level Contributed by the Noise Source at NSA (L<sub>dn</sub>)</b>	<b>L<sub>dn</sub> during Construction (including background levels)</b>	
NSA 1	7,875 feet SE	50.9	49.1	53.2	2.3
NSA 2	6,235 feet SW	48.0	49.5	51.8	3.8
NSA 3	6,560 feet W	48.8	48.7	51.9	3.1
NSA 4	6,560 feet NW	48.6	51.3	53.3	4.7
NSA 5	3,280 feet NE	49.3	55.0	56.0	6.7

Source: CB&I, 2014

Abbreviations:  
dBA = A-weighted decibel  
L<sub>dn</sub> = day-night sound level

E = East  
W = West  
N = North  
S = South

### Pipeline Expansion

Construction of the Pipeline Expansion would take place for about 15 months. The nearest NSAs for each component of the Pipeline Expansion are shown in table 4.11.2-5.

<b>TABLE 4.11.2-5</b>		
<b>Noise Levels of Typical Construction Equipment at Compressor Stations for the Pipeline Expansion</b>		
<b>Equipment</b>	<b>Assumed Maximum Number Operating at One Time</b>	<b>Equipment PWL (dBA)</b>
Diesel generator	1	102
Bulldozer	1	110
Grader	1	105
Backhoe	1	104
Front end loader	1	102
Truck loaded	1	105
<b>Estimated Total Maximum PWL of All Equipment (dBA)</b>		<b>113</b>

Sources: H&K 2014a, 2014b, 2014c

Abbreviations:  
dBA = A-weighted decibel  
PWL = sound power level

Compressor Stations

Predicted noise levels at the nearest NSA were estimated based on their distances to the Project site and the PWLs of construction equipment that typically operate during a construction activity, as well as the estimated collective PWL of all equipment assumed to operate at the same time. Table 4.11.2-5 shows a list of typical equipment that would be operated simultaneously during construction of the MP 1, MP 33, and MP 66 Compressor Stations, and the corresponding PWL. The resulting combined PWL of all the equipment is estimated at 113 dBA, which is used as the basis to predict the Project’s noise impact on the nearest (worst-case) NSA to the respective compressor station, as shown in table 4.11.2-6.

TABLE 4.11.2-6						
Noise Levels during Construction of Compressor Stations for the Pipeline Expansion						
Compressor Station (Nearest NSA)	Distance and Direction	Sound Levels (dBA)			L <sub>dn</sub> during Construction (Including Background Levels)	Change in Background Sound Level (dBA)
		Background (L <sub>dn</sub> )	Noise Level Contributed by the Noise Source at NSA (L <sub>dn</sub> ) <sup>a</sup>	Shield Factor <sup>b</sup>		
MP 1 (NSA 5)	2,030 feet W	49.3	49.2	-6	50.1	0.9
MP 33 (NSA 3)	1,150 feet NE	48.1	54.1	0	55.1	2.0
MP 66 (NSA 3)	2,780 feet E	45.0	46.4	-6	46.3	1.3

Sources: H&K, 2014a, 2014b, 2014c

Abbreviations:  
dBA = A-weighted decibel  
L<sub>dn</sub> = day-night equivalent sound level

E = East  
W = West  
N = North  
S = South

Notes:  
**a** The resulting decrease in noise (ΔSPL) due to hemispherical propagation at a distance (r) from a noise source PWL is estimated using the following equation:  $\Delta\text{SPL} = 20\text{Log}_{10}(r) - 2.3$  dBA. Therefore, the estimated noise L<sub>dn</sub> at NSA would be:  $L_{dn} = 113 \text{ dBA} - \Delta\text{SPL}$ .  
**b** Shield factor due to air absorption or foliage.

As shown in table 4.11.2-6, the increase in noise levels at the nearest NSAs during construction of the MP 1, MP 3, and MP 66 Compressor Stations would not exceed our noise criterion of an L<sub>dn</sub> of 55 dBA and is not expected to result in significant adverse impacts on the NSAs. Similar to the Terminal Expansion, increases in sound levels during construction activities would be intermittent and generally would occur during daylight hours.

Calcasieu Loop Pipeline Section

Sound level increases during pipeline construction would be intermittent and generally would occur during daylight hours, with the exception of some HDD activities. The HDD operations at the entry and exit locations would generate high noise levels at the source location. However, because the distance to the nearest NSA is more than 2,000 feet, HDD noise would attenuate to levels less than 55 dBA at the NSA. For the purposes of this study, the noise impact analysis assumes a worst-case scenario, with HDD operations conducted on a 24-hour-per-day work schedule, no shield factor due to foliage or obstructions, and construction activities at MP 66 Compressor Station occurring simultaneously (H&K, 2014c, 2014d). The estimated PWLs at the HDD entry and exit locations are estimated at 115.2 dBA and 103.2 dBA, respectively. HDD operation would take place for about 4 months.

The following is a list of typical equipment operated at the entry location:

- drilling rig and engine-driven hydraulic power unit (most significant noise source);
- engine-driven mud pump(s) and engine-driven generator set(s);
- mud mixing/cleaning equipment and associated fluid systems shale shakers;
- crane, backhoe, front loader, forklift and/or truck(s); and
- portable tanks (i.e., water and drilling mud storage); engine-driven light plants (nighttime operation).

The following is a list of typical equipment operated at the exit location:

- backhoe, side-boom backhoe, and/or trucks;
- one engine-driven generator set and one “small” engine-driven pump; and
- engine-driven light plants (used for nighttime operation).

Table 4.11.2-7 summarizes the total noise levels produced by the equipment operating at the HDD entry and exit locations, combined with the construction noise at the MP 66 Compressor Station, and the resulting noise levels at the nearest NSAs.

The noise levels at the nearest NSAs from HDD operations during construction of the Calcasieu Loop would be below our noise criterion of an  $L_{dn}$  of 55 dBA and are not expected to result in adverse impacts on the NSAs. Increases in noise levels during construction activities would be temporary.



**TABLE 4.11.2-7**

**Noise Levels during HDD Operations and Construction of the MP 66 Compressor Station**

Nearest NSA	Noise Source	NSA Distance and Direction to Noise Source	Sound Levels (dBA)			
			NSA Background Noise Level (L <sub>dn</sub> )	Noise Levels Contributed by the Noise Sources at NSA (L <sub>dn</sub> ) <u>a</u>	Combined L <sub>dn</sub> at NSA (HDD + MP 66 CS + Background) <u>b</u>	Change in Background Noise Level (dBA)
NSA 2	HDD Entry	7,200 feet SE		38.7		
	HDD Exit	3,250 feet SE	48.4	37.4	49.5	1.1
	MP 66 CS	7,450 feet SSE		38.7		
NSA 3	HDD Entry	2,433 feet NE		52.2		
	HDD Exit	5,814 feet NE	45.0	30.3	54.8	9.8
	MP 66 CS	2,780 feet E		50.2		

Source: H&K, 2014d

Abbreviations:  
 dBA = A-weighted decibel  
 L<sub>dn</sub> = day-night equivalent sound level  
 CS = Compressor Station

Notes:  
a The resulting decrease in noise (ΔSPL) due to hemispherical propagation at a distance (r) from a noise source PWL is estimated using the following equation:  $\Delta\text{SPL} = 20\text{Log}_{10}(r) - 2.3$  dBA. Therefore, the estimated noise L<sub>dn</sub> at NSA would be:  $L_{dn} = \text{Total equipment PWL} - \Delta\text{SPL}$ .  
b Noise levels were calculated using the equation for adding unequal sound pressure levels (SPL):  $\text{SPL}_{\text{Total}} = 10\text{Log}_{10}[10^{\text{SPL}_1/10} + 10^{\text{SPL}_2/10} + \dots + 10^{\text{SPL}_n/10}]$

#### 4.11.2.5 Operations Noise Impacts and Mitigation

##### Terminal Expansion

##### Flare Operations

Golden Pass would install three new flares as part of the Terminal Expansion. These flares would consist of a wet flare, a dry flare and a low pressure flare. The wet and dry flares would be a distributed ground flare field located east of the LNG Train No. 3 and enclosed in a radiation fence; while the low pressure flare would be a single tip elevated flare located within the existing Golden Pass Import Terminal site facilities.

Noise levels from flare operations were assessed based on two types of operations: planned (scheduled, such as in startups, pre-treatment, or liquefaction depressurization) and unplanned (unscheduled, such as in emergency flare incidents). As provided by equipment vendors, sound emission levels are 125 dBA per tip for the wet flare, 126 dBA per tip for the dry flare, and 118 dBA at 60 kilo pound per hour for the low pressure flare. Noise levels resulting from flare operations at the five NSA's (see figure 4.11.2-1) were predicted using SoundPLAN Version 7.4 noise modeling program and ISO 9613 methodology (H&K 2015).

Several flaring scenarios during planned and unplanned flaring operations have been considered in the noise assessment for this study. Table 4.11.2-8 shows each flare's corresponding distance to and projected noise levels at each NSA, as well as the resulting ambient noise increases at the NSAs for a worst case scenario during planned and unplanned flaring events. The worst-case noise impact level estimated at 69.8 dBA  $L_{dn}$  would occur at the nearest NSA (NSA 5 located about 3,500 feet from the dry flare source) during an annual final warm startup for planned flaring and in the event that emergency pressure relief for one train is necessary while a second train is in start-up of the cold section, as a result of a blocked propane refrigerant compressor. This noise level would cause a high noise increase at the nearest NSA, which has an existing ambient noise level of 49.3 dBA. This estimated noise level would be above our noise criterion of 55 dBA  $L_{dn}$ . Note, however, that these flaring events do not occur continuously but rather occasionally for a relatively short period of time. However, the noise impact assessment presented in table 4.11.2-8 does not include noise generated from other sources in the vicinity.

TABLE 4.11.2-8

## Noise Levels during Flare Operations at the Terminal Facility

		Sound Levels (dBA)						
NSA	Noise Source	NSA Distance and Direction to Noise Source <u>a</u>	Worst-case Ambient Noise Levels during Planned Flaring Operations <u>b</u>			Worst-case Ambient Noise Levels during Unplanned Flaring Operations <u>d</u>		Change in Background Noise Level (dBA)
			NSA Background Noise Level (L <sub>dn</sub> )	Noise Levels from Flare at NSA (L <sub>dn</sub> )	Combined, NSA Background+ Flare (L <sub>dn</sub> ) <u>c</u>	Noise Levels from Flare at NSA (L <sub>dn</sub> )	Combined, NSA Background+ Flare (L <sub>dn</sub> ) <u>b</u>	
NSA 1	Wet Flare	7,750 feet SE		59.2	59.6	52.6	54.8	2.6 – 8.3
	Dry Flare	7,750 feet SE	50.9	61.4	61.8	59.4	60.0	8.5 – 10.5
	Low Pressure Flare	11,750 feet SE		22.4	50.9	24.9	50.9	0
NSA 2	Wet Flare	9,750 feet WSW		54.9	55.7	48.5	51.3	0.5 – 6.9
	Dry Flare	9,750 feet WSW	48.0	57.9	58.3	56.4	57.0	8.4 – 9.9
	Low Pressure Flare	7,250 feet SW		25.5	48.0	28.1	48.0	0
NSA 3	Wet Flare	10,250 feet WNW		54.5	55.5	48.2	51.5	2.7 – 6.7
	Dry Flare	10,250 feet WNW	48.8	57.7	58.2	56.2	56.9	8.1 – 9.4
	Low Pressure Flare	6,500 feet WSW		27.9	48.8	30.5	48.9	0 – 0.1
NSA 4	Wet Flare	8,750 feet NW		55.8	56.6	49.6	52.1	3.5 – 8.0
	Dry Flare	8,750 feet NW	48.6	59.4	59.7	58.6	59.0	10.4 – 11.1
	Low Pressure Flare	5,250 feet NW		34.0	48.7	36.6	48.9	0.1 – 0.3
NSA 5	Wet Flare	3,500 feet NW		65.4	65.5	59.5	59.9	10.2 – 16.2
	Dry Flare	3,500 feet NW	49.3	69.8	69.8	69.8	69.8	20.5
	Low Pressure Flare	3,750 feet NE		41.9	50.0	44.5	50.5	0.7 – 1.2

**TABLE 4.11.2-8 (continued)**

**Noise Levels during Flare Operations at the Terminal Facility**

Source: H&K, 2015

Abbreviations:

dBA = A-weighted decibel

E = East

N = North

L<sub>dn</sub> = day-night equivalent sound level

W = West

S = South

Note:

**a** Estimated distances based on scale provided in figure 4.11.2-1

**b** Worst-case scenario during planned flaring operations would occur during final warm startup of dry gas flaring. This flaring event is estimated to occur once per year at a total flaring rate of 485,046 lb/hr for 22 hours.

**c** Noise levels were calculated using the equation for adding unequal sound pressure levels (SPL):  $SPL_{Total} = 10\log_{10}[10^{SPL1/10} + 10^{SPL2/10} + \dots + 10^{SPLn/10}]$

**d** Worst-case scenario during unplanned flaring operations would occur in the event of an emergency pressure relief for one train while a second train is in start-up of the cold section, due to propane refrigerant compressor blockage. This flaring event is estimated to occur once during the facility's lifetime (25 years) with a total flaring rate of 5,910,000 lb/hr for about half an hour.

### MP 1 Compressor Station

Noise from the MP 1 Compressor Station would be generated from continuous operations of two electric motor-driven compressor units, each consisting of a 6,714 kilowatt electric motor driving a centrifugal gas compressor. The estimated  $L_{dn}$  of the MP 1 Compressor Station would be 49.2 dBA at the nearest NSA (NSA 3, located 2,030 feet from the compressor station). This noise level would not cause a perceivable noise increase at the nearest NSA, which has an existing ambient noise level of 49 dBA. This estimated noise level would be below our noise criterion of 55 dBA  $L_{dn}$ .

Table 4.11.2-9 shows noise impacts on the NSAs during operation of the Terminal Expansion and MP 1 Compressor Station.

### Mitigation Measures

In addition to the noise-mitigating design features of equipment to be used for the Project, Golden Pass would apply the following mitigation measures to ensure compliance with our noise criterion:

- House the gas turbine drivers in acoustically treated enclosures and install mufflers in the intake and exhaust system and lagging of ducting;
- For the heat recovery steam generator, install exterior acoustical lagging and muffler for steam releases;
- For the electric generator, install acoustical/thermal equipment insulation and enclose in an acoustically treated equipment shed;
- For the packaged equipment items, install acoustical pipe lagging; and
- House the compressors in an acoustically treated metal building and install exhaust stack silencers and combustion air intake silencers.

TABLE 4.11.2-9

## Noise Levels during Operations at the Terminal Expansion and MP 1 Compressor Station

NSA	Noise Source	NSA Distance and Direction to Noise Source	Sound Levels (dBA)			
			NSA Background Noise Level (L <sub>dn</sub> )	Noise Levels Contributed by the Noise Sources at NSA (L <sub>dn</sub> )	Combined L <sub>dn</sub> at NSA (Terminal Expansion + MP 1 CS + Background) <sup>a</sup>	Change in Background Noise Level (dBA)
NSA 1	Terminal Expansion	7,875 feet SE	50.9	49.1	53.1	2.2
	MP 1 CS	14,000 feet SE		15.4		
NSA 2	Terminal Expansion	6,235 feet SW	48.0	49.5	51.8	3.8
	MP 1 CS	3,470 feet SSW		29.4		
NSA 3	Terminal Expansion	6,560 feet W	48.8	48.7	52.0	3.2
	MP 1 CS	2,030 feet W		35.2		
NSA 4	Terminal Expansion	6,560 feet NW	48.6	51.3	53.3	4.7
	MP 1 CS	4,720 feet N		25.9		
NSA 5	Terminal Expansion	3,280 feet SE	49.3	55.0	56.0	6.7
	MP 1 CS	7,160 feet NE		21.2		

Sources: CB&I, 2014; H&K, 2014

Abbreviations:  
dBA = A-weighted decibel  
L<sub>dn</sub> = day-night equivalent sound level  
CS = compressor station

Note:  
<sup>a</sup> Noise levels were calculated using the equation for adding unequal sound pressure levels (SPL):  $SPL_{Total} = 10\log_{10}[10^{SPL1/10} + 10^{SPL2/10} + \dots + 10^{SPLn/10}]$

In addition to the mitigation measures identified above, to ensure that NSAs are not significantly affected by noise during operation of the Terminal Expansion and MP 1 Compressor Station and to keep noise at an acceptable level of an  $L_{dn}$  of 55 dBA or less, **we recommend that:**

- **Golden Pass should file a full power load noise survey with the Secretary for the Terminal Expansion no later than 60 days after each liquefaction train is placed into service. If the noise attributable to operation of the equipment at the Terminal Expansion and MP 1 Compressor Station exceeds an  $L_{dn}$  of 55 dBA at the nearest NSA, Golden Pass should reduce operation of the liquefaction facilities or install additional noise controls until a noise level below an  $L_{dn}$  of 55 dBA at the NSA is achieved. Golden Pass should confirm compliance with the above requirement by filing a second noise survey with the Secretary no later than 60 days after it installs the additional noise controls.**
- **Golden Pass should file a noise survey with the Secretary no later than 60 days after placing the entire Terminal Expansion, including the MP 1 Compressor Station, into service. If a full load condition noise survey is not possible, Golden Pass should provide an interim survey at the maximum possible horsepower load within 60 days of placing the Terminal Expansion and MP 1 Compressor Station into service and provide the full load survey within 6 months. If the noise attributable to operation of the equipment at the Terminal Expansion and MP 1 Compressor Station exceeds an  $L_{dn}$  of 55 dBA at the nearest NSA under interim or full horsepower load conditions, Golden Pass should file a report on what changes are needed and should install the additional noise controls to meet the level within 1 year of the in-service date. Golden Pass should confirm compliance with the above requirement by filing an additional noise survey with the Secretary no later than 60 days after it installs the additional noise controls.**

Based on the results of the noise analysis and our recommendation, we believe that operations noise from the Terminal Expansion and MP 1 Compressor Station would cause no significant impact on the noise environment in the vicinity of the Terminal Expansion.

## **Pipeline Expansion**

### MP 33 and MP 66 Compressor Stations

Operation of the MP 33 and MP 66 Compressor Stations and maintenance activities at those stations would increase sound levels. The increases would occur for the life of the Project. The major noise-generating equipment at the compressor stations during operation include gas turbine-driven centrifugal natural gas compressor units, each equipped with a combustion hot gas exhaust stack, a combustion air intake, air-cooled after-gas cooler banks, and an air-cooled lube oil cooler.

Gas blowdown venting also would occur at the compressor stations. A blowdown silencer would be installed and designed such that the blowdown SPL would not exceed the 55 dBA  $L_{dn}$  standard at the nearest NSA to the compressor stations. Noise from blowdown events would be infrequent and short term (lasting for about 1 to 5 minutes); thus, the noise impact would be minimal.

Table 4.11.2-10 summarizes the existing ambient noise levels and the predicted operations noise levels at the nearest NSAs for the MP 33 and MP 66 Compressor Stations. These noise impacts were evaluated based on normal full-load operations of the MP 33 and MP 66 Compressor Stations, with identified mitigation measures applied.

TABLE 4.11.2-10					
Noise Levels during Operations at the MP 33 and MP 66 Compressor Stations					
NSA	Distance and Direction	Sound Levels (dBA)			Change in Background Sound Level (dBA)
		NSA Background Noise Level (L <sub>dn</sub> )	Noise Level Contributed by the Noise Source at NSA (L <sub>dn</sub> )	L <sub>dn</sub> during Operations (Including Background Levels) at NSA <u>a</u>	
<b>MP 33 Compressor Station</b>					
1	1,150 feet NE	48.1	49.9	52.1	4.0
2	1,260 feet E	56.1 <u>b</u>	49.0	56.9 <u>b</u>	0.8
3	3,470 feet N	44.9	39.1	45.9	1.0
<b>MP 66 Compressor Station</b>					
1	7,680 feet SW	50.1	44.7	51.5	1.4
2	7,450 feet SSE	48.4	45.1	50.4	2.0
3	2,780 feet E	45.0	54.2	53.8	8.8
Sources: H & K, 2014b, 2014c					
<u>Abbreviations:</u>					
dBA = A-weighted decibel		E = East		N = North	
L <sub>dn</sub> = day-night equivalent sound level		W = West		S = South	
<u>Notes:</u>					
<u>a</u>	Noise levels are calculated using the equation for adding unequal sound pressure levels (SPL): SPL <sub>Total</sub> = 10Log <sub>10</sub> [10 <sup>SPL<sub>1</sub>/10</sup> + 10 <sup>SPL<sub>2</sub>/10</sup> + ... 10 <sup>SPL<sub>n</sub>/10</sup> ]				
<u>b</u>	Although the Project noise level at the NSA (49 dBA) is below our noise L <sub>dn</sub> criterion of 55 dBA, the resulting L <sub>dn</sub> combined with the ambient noise at the NSA would be above 55 dBA because the existing ambient noise level of the NSA at 56.1 dBA is already above our criterion.				

As shown in table 4.11.2-10, overall noise levels contributed by the Project at the nearest NSA would be below our criterion of 55 dBA L<sub>dn</sub>. The highest potential increase would be 8.8 dBA at the MP 66 Compressor Station, which would be a noticeable increase in noise at the NSA.

### Mitigation Measures

Golden Pass would implement mitigation measures to reduce noise impacts, such as installing the compressor units in an acoustically designed building. Golden Pass also would install exhaust stack silencers and combustion air intake silencers as necessary to comply with our noise criterion.

Based on our noise analysis, the predicted noise levels attributable to operation of the MP 33 and MP 66 Compressor Stations would be less than 55 dBA L<sub>dn</sub> at all nearby NSAs, except at NSA 2 for the MP 33 Compressor Station, which has an existing background noise level already above the criterion of 55 dBA L<sub>dn</sub>. To ensure that the noise from the compressor stations does not significantly exceed an L<sub>dn</sub> of 55 dBA at the nearest NSAs, **we recommend that:**

- **Golden Pass should file a full power load noise survey for the MP 33 and MP 66 Compressor Stations no later than 60 days after placing the stations into service. If a full power load condition noise survey is not possible, Golden Pass should file an interim survey at the maximum possible power load within 60 days of placing the stations into**



**service and file the full power load survey within 6 months. If the noise attributable to operation of all equipment at the stations under interim or full power load conditions exceeds an  $L_{dn}$  of 55 dBA at any nearby NSA, Golden Pass should:**

- a. file a report with the Secretary, for review and written approval by the Director of OEP, on what changes are needed;**
- b. install additional noise controls to meet that level within 1 year of the in-service date; and**
- c. confirm compliance with this requirement by filing a second full power load noise survey with the Secretary, for review and written approval by the Director of OEP, no later than 60 days after Golden Pass installs the additional noise controls.**

#### Calcasieu Loop Pipeline Section

The only sound level increases associated with operation of the Calcasieu Loop pipeline would be indirect noise from vehicle and equipment use during maintenance and inspection activities. However, these activities would be transient, temporary when they do occur, and not significantly more audible than normal vehicle traffic at the nearest NSAs along the pipeline right-of-way.

Based on the noise analysis and our recommendation, we believe that operation of the Pipeline Expansion would not cause a significant impact on the noise environment in the vicinity of the Pipeline Expansion.

## **4.12 RELIABILITY AND SAFETY**

### **4.12.1 Terminal Expansion**

#### **4.12.1.1 Regulatory Agencies**

Multiple federal agencies share regulatory authority over the siting, design, construction, and operation of LNG import and export terminals. The safety, security, and reliability of the Golden Pass LNG Export Project would be governed by the FERC, the DOT, and the Coast Guard.

The FERC authorizes the siting and construction of LNG import and export facilities under the NGA and delegated authority from the DOE. The FERC requires standard information to be submitted to perform safety and reliability engineering reviews. FERC's filing regulations are codified in 18 CFR 380.12 (m) and (o), and requires each applicant to identify how its proposed design would comply with the DOT's siting requirements of 49 CFR 193, Subpart B. The level of detail necessary for this submittal requires the Project sponsor to perform substantial front-end engineering of the complete facility. The design information is required to be site-specific and developed to the extent that further detailed design would not result in changes to the siting considerations, basis of design, operating conditions, major equipment selections, equipment design conditions, or safety system designs that we considered during our review process. As part of the review required for a FERC authorization, we use this information from the applicant to assess whether a facility would have a public safety impact.

The DOT establishes federal safety standards for the siting, construction, operation, and maintenance of onshore LNG facilities, as well as for the siting of marine cargo transfer systems at waterfront LNG plants. Those regulations are codified in 49 CFR 193. In 1985, the FERC and the DOT entered into a memorandum of understanding (MOU) regarding the execution of each agency's respective statutory responsibilities to ensure the safe siting and operation of LNG facilities. In addition to the FERC's existing ability to impose requirements to ensure or enhance the operational reliability of LNG facilities,

the MOU specified that the FERC may, with appropriate consultation with the DOT, impose more stringent safety requirements than those in Part 193. As a cooperating agency, the DOT assists the FERC staff in evaluating whether an applicant's proposed siting meets the DOT requirements. If a facility is constructed and becomes operational, the facility would be subject to the DOT's inspection program. Final determination of whether a facility is in compliance with the requirements of 49 CFR 193 would be made by the DOT staff.

The Coast Guard has authority over the safety of an LNG facility's marine transfer area and LNG marine traffic, as well as over security plans for the entire LNG facility and LNG marine traffic. The Coast Guard regulations over LNG facilities are codified in 33 CFR 105 and 127. As a cooperating agency, the Coast Guard assists the FERC staff in evaluating whether an applicant's proposed waterway would be suitable for marine traffic and whether a facility would be in accordance with 33 CFR 127 and 105. If a facility is constructed and becomes operational, the facility would be subject to the Coast Guard inspection program. Final determination of whether a facility is in compliance with the requirements of 33 CFR 127 and 33 CFR 105 would be made by the Coast Guard.

In February 2004, the Coast Guard, the DOT, and the FERC entered into an Interagency Agreement to ensure greater coordination among these three agencies in addressing the full range of safety and security issues at LNG terminals, including terminal facilities and tanker operations, and maximizing the exchange of information related to the safety and security aspects of the LNG facilities and related marine operations. Under the Interagency Agreement, the FERC is the lead federal agency responsible for the preparation of the analysis required under NEPA for impacts associated with terminal construction and operation. The DOT and the Coast Guard participate as cooperating agencies but remain responsible for enforcing their regulations covering LNG facility design, construction, and operation.

#### **4.12.1.2 Hazards Associated with the Proposed Facilities**

Before liquefaction, Golden Pass would pre-treat the natural gas feed stream to remove components that would be incompatible with the liquefaction process or equipment, including mercury, H<sub>2</sub>S, CO<sub>2</sub>, water, and heavy hydrocarbons. In general, mercury can result in toxic effects if contacted, ingested, or inhaled. Hydrogen sulfide gas can be flammable and is also toxic upon inhalation, while CO<sub>2</sub> gas can cause respiratory irritation or asphyxiation. The heavier hydrocarbons would contain toxic components and would be flammable.

Mercury would be removed from the gas by beds of a UOP GB-type adsorbent that reacts to form mercury sulfide until the beds adsorb enough mercury to require replacement. The proposed pre-treatment system would be capable of handling a natural gas feed stream with up to 1,000 nanograms per standard cubic meter of mercury; however, lower concentration would be expected in the feed gas stream. Replacement of these mercury adsorber beds would occur less frequently than every 6 years and would need to be conducted in accordance with applicable regulations.

The CO<sub>2</sub> and H<sub>2</sub>S would be removed from the feed gas by contact with an amine-based solvent solution in an absorber column. The proposed pre-treatment system would be capable of handling a natural gas feed stream with up to 4 parts per million by volume (ppmv) of H<sub>2</sub>S, and 2 mole percent CO<sub>2</sub>. After CO<sub>2</sub> and H<sub>2</sub>S had accumulated in the amine solution, an amine regenerator would release the CO<sub>2</sub> and H<sub>2</sub>S from that solution into an acid gas stream. The concentrations of H<sub>2</sub>S and CO<sub>2</sub> in the acid gas stream could reach 200 ppmv and 96 mole percent, respectively, during this process. Most of the H<sub>2</sub>S in the acid gas stream would be chemically removed by a liquid scavenger solution. The H<sub>2</sub>S would chemically react with the scavenger solution, forming a substance from which Golden Pass states that the H<sub>2</sub>S could no longer be liberated, and that is typically not toxic. Spent scavenger solution would be removed from the site by truck in accordance with applicable regulations.

The gas leaving the scavenger unit would be sent to a thermal oxidizer, where any remaining traces of H<sub>2</sub>S and hydrocarbons would be incinerated. Due to the relatively low rates of CO<sub>2</sub> to be processed and the high concentrations of CO<sub>2</sub> needed to cause asphyxiation, safety hazards associated with CO<sub>2</sub> would be localized at the thermal oxidizer vent stack or release location. Therefore, CO<sub>2</sub> would not be expected to pose a significant safety hazard to the public, which would have no access to onsite areas. The hazards associated with a release of H<sub>2</sub>S in the acid gas stream, before it reached the scavenger system, are described further in the following subsections and in section 4.12.1.8.

The amine and scavenger solutions could generally be flammable or irritating to the skin, eyes, or lungs upon short-term contact or inhalation. Extremely high vapor concentrations of the amine solution could cause lung damage. However, the equipment containing the amine and scavenger solutions would be provided with impoundment for potential releases, and the solutions would be handled at temperatures below the point at which they could produce enough vapors to form a flammable mixture. Therefore, the amine and scavenger solutions would not pose a significant hazard to the public, which would have no access to onsite areas. The containment of amine is discussed further in section 4.12.1.5.

Water would be removed from the feed gas by a dehydration unit using regenerative molecular sieve beds. The water would be recovered for use within the pre-treatment system and would not pose a significant safety hazard to the public.

A Heavy Hydrocarbon Removal Unit would be used to extract the heavy hydrocarbons from the feed gas. The resulting heavy hydrocarbon stream would be stabilized and sent to the condensate storage tank. From there, condensate would be removed from the site by truck, potentially one to four times daily. A loss of containment from the hydrocarbon condensate facilities would result in a release of both toxic components and flammable components, with the ability to produce damaging overpressures. The primary toxic components in the hydrocarbon condensate stream would include benzene, toluene, xylenes, hexanes, and methyl mercaptan. The associated hazards are further described in the following subsections and in sections 4.12.1.7 through 4.12.1.10.

After removal of the heavy hydrocarbons and the other components from the natural gas feed stream, Golden Pass would liquefy the natural gas. In this process, the gas would be cooled by thermal exchange with progressively colder refrigerants. Propane refrigerant would be used to pre-cool the feed gas; then mixed-refrigerant, consisting of nitrogen, methane, ethylene, and propane, would be used to achieve the liquefaction temperature. After cooling the natural gas into its liquid form, this LNG would be stored in the existing full-containment LNG storage tanks. The principal hazards associated with a release of LNG or refrigerants would be the potential for flammable vapor dispersion, radiant heat from a fire, and the ability to produce damaging overpressures. These hazards are further described in the following subsections and in sections 4.12.1.7, 4.12.1.9, and 4.12.1.10.

In addition, aqueous ammonia would be used as part of the emission control system associated with the Project. Aqueous ammonia can be toxic. The potential hazard from an aqueous ammonia release is further described in section 4.12.1.8.

### **Hazardous Releases**

A release of hazardous fluid from piping or equipment is the initial event that could result in all other potential hazards. This initial loss of containment can produce a liquid and/or gaseous release with the formation of vapor at the release location as well as at the location of any liquid that may have pooled. The released fluid may present low or high temperature hazards and may result in the formation of toxic and/or flammable vapors. The extent of the hazards depends on the material released, the storage and process conditions, and the volumes released.

LNG and liquid nitrogen are typically stored near their boiling points, at approximately -260 and -320 °F, respectively, and at near-ambient pressures. Ethylene is typically stored at temperatures below -20 °F and at pressures above 100 psig. Propane is typically stored at close to ambient temperature and at pressures above 100 psig. Heavier condensates are typically stored at close to ambient temperature and pressures. In order for the natural gas to be cooled into LNG, the refrigerants also typically need to reach temperatures approaching -260 °F. System pressures in the liquefaction area of an LNG plant can typically reach hundreds of psi, and in some cases exceed 1,000 psi.

Loss of containment of these liquids could lead to the release of both liquid and vapor into the immediate area. Exposure to either cold liquid or vapor could cause freeze burns and, depending on the length of exposure, more serious injury or death. However, spills would be contained to onsite areas, and the extent of the cold vapor state from these releases would be greatly limited due to the continuous mixing with the warmer air. The cold temperatures from the release would not present a hazard to the public, which would not have access to onsite areas.

These releases may also quickly cool any materials contacted by the liquid, causing extreme thermal stress in materials not specifically designed for such conditions. These thermal stresses could subsequently subject the material to brittleness, fracture, or other loss of tensile strength. These temperatures, however, would be accounted for in the design of equipment and structural supports, and would not be substantially different from the hazards associated with the storage and transportation of liquid oxygen (-296 °F) or several other cryogenic liquids that have been routinely produced and transported in the United States.

A rapid phase transition (RPT) can occur when a cryogenic liquid is spilled onto water and changes from liquid to gas, virtually instantaneously. Unlike an explosion that releases energy and combustion products from a chemical reaction, an RPT is the result of heat transferred to the liquid, inducing a change to the vapor state. RPTs have been observed during LNG test spills onto water. In some test cases, the overpressures generated were strong enough to damage test equipment in the immediate vicinity of the LNG release point. The sizes of the overpressure events have been generally small and did not cause significant damage. The average overpressures recorded at the source of the RPTs during the Coyote tests have ranged from 0.2 to 11 psi.<sup>41</sup> These events are typically limited to the area within the spill and are not expected to cause damage outside of the area engulfed by the LNG pool. However, an RPT may affect the rate of pool spreading and the rate of vaporization for a spill on water. Regardless, the proposed Golden Pass LNG Export Project facilities would not be expected to release into the SNWW, and the LNG sumps are required by 49 CFR 193.2173 to be constructed so that all areas drain completely to prevent water collection.

### **Vapor Dispersion**

In the event of a release, the LNG, refrigerants, or condensate would produce vapor. Depending on the size of the release, these liquids may also form a liquid pool that would continue to vaporize because of exposure to ambient heat sources, such as water or soil. If released, LNG will generally produce from 620 to 630 standard cubic feet (ft<sup>3</sup>) of gas for each cubic foot of liquid. Liquid nitrogen could produce from 500 to 700 ft<sup>3</sup> of gas for each cubic foot of liquid. Typically, ethylene will produce approximately 380 ft<sup>3</sup> of gas for each cubic foot of liquid. Propane will produce approximately 267 ft<sup>3</sup> of gas for each cubic foot of liquid. Hydrocarbon condensate could be expected to produce 200 ft<sup>3</sup> or lower volumes of gas per cubic foot of liquid.

---

<sup>41</sup> The Lawrence Livermore National Laboratory conducted seven tests (the Coyote series) on vapor cloud dispersion, vapor cloud ignition, and RPTs at the Naval Weapons Center in China Lake, California in 1981.

The vapor may form a toxic or flammable cloud, depending on the material released. The dispersion of the vapor cloud will depend on the physical properties of the cloud, the ambient conditions, and the surrounding terrain and structures. Generally, a denser-than-air vapor cloud would sink to the ground due to the relative density of the vapor to the air and would travel with the prevailing wind, while a lighter-than-air vapor cloud would rise and travel with the prevailing wind. The density depends on the material released and the temperature of the material. For example, an LNG release would initially form a denser-than-air vapor cloud and transition to a lighter-than-air vapor cloud as the vapor disperses downwind and mixes with the warm surrounding air; a liquid ethylene or nitrogen release would form a denser-than-air vapor cloud and transition to a neutrally buoyant vapor cloud as it mixes with the warm surrounding air; and a propane or condensate release would form a denser-than-air vapor cloud that would remain denser than the surrounding air, even after warming to ambient temperatures. However, experimental observations and vapor dispersion modeling indicate that an LNG vapor cloud would not typically be warm, or buoyant, enough to lift off from the ground before the LNG vapor cloud disperses below its lower flammable limit (LFL).

The vapor cloud would continue to be hazardous until it dispersed below toxic levels and/or flammable limits. Toxicity is primarily dependent on the concentration of the vapor cloud in the air and the exposure duration, while flammability of the vapor cloud primarily depends only on the concentration of the vapor when mixed with the surrounding air. In general, higher concentrations within the vapor cloud would exist near the spill, and lower concentrations would exist near the edge of the cloud as it disperses downwind.

Toxicity is defined by a number of different agencies for different purposes. Acute Exposure Guideline Levels (AEGL) and Emergency Response Planning Guidelines (ERPG) are recommended for use by federal, state, and local agencies as well as the private sector for emergency planning, prevention, and response activities related to the accidental release of hazardous substances.<sup>42</sup> Other federal agencies, such as the Department of Energy, EPA, and NOAA, use AEGLs and ERPGs as the primary measure of toxicity.<sup>43, 44, 45</sup>

There are three AEGLs and three ERPGs that are distinguished by varying degrees of severity of toxic effects, with AEGL-1 and ERPG-1 (Level 1) being the least severe to AEGL-3 and ERPG-3 (Level 3) being the most severe.

- AEGL-1 is the airborne concentration of a substance above which it is predicted that the general population, including susceptible individuals, could experience notable discomfort, irritation, or certain asymptomatic non-sensory effects. However, these effects are not disabling and are transient and reversible upon cessation of the exposure.
- AEGL-2 is the airborne concentration of a substance above which it is predicted that the general population, including susceptible individuals, could experience irreversible or other serious, long-lasting adverse health effects or an impaired ability to escape.

---

<sup>42</sup> U.S. Environmental Protection Agency, *Dose-Response Assessment for Assessing Health Risks Associated with Exposure to Hazardous Air Pollutants*, <http://www2.epa.gov/fera/dose-response-assessment-assessing-health-risks-associated-exposure-hazardous-air-pollutants>, July 3, 2014.

<sup>43</sup> U.S. Department of Energy, *Temporary Emergency Exposure Limits for Chemicals: Methods and Practice*, DOE Handbook, DOE-HDBK-1046-2008, August 2008.

<sup>44</sup> U.S. Environmental Protection Agency, *40 CFR 68 Final Rule: Accidental Release Prevention Requirements: Risk Management Programs Under Clean Air Act Section 112(r)(7)*, 61 Federal Register 31667-31732, Vol. 61, No. 120, Thursday, June 20, 1996.

<sup>45</sup> U.S. National Oceanic and Atmospheric Administration, *Public Exposure Guidelines*, <http://response.restoration.noaa.gov/oil-and-chemical-spills/chemical-spills/resources/public-exposure-guidelines.html>, December 3, 2013.

- AEGL-3 is the airborne concentration of a substance above which it is predicted that the general population, including susceptible individuals, could experience life-threatening health effects or death.

The EPA directs the development of AEGLs in a collaborative effort consisting of committee members from public and private sectors across the world. The FERC staff uses AEGLs preferentially as they are more inclusive and provide toxicity levels at various exposure times (10 minutes, 30 minutes, 1 hour, 4 hours, and 8 hours). The use of AEGLs is also preferred by the DOE and NOAA and DOT Federal Aviation Administration (FAA).

ERPG levels have similar definitions but are based on the maximum airborne concentration below which it is believed that nearly all individuals could be exposed for up to 1 hour without experiencing similar effects defined in each of the AEGLs. The EPA provides ERPGs (1 hour) for a list of chemicals. EPA currently requires the determination of distances to toxic concentrations based on ERPG-2 levels. DOT Pipeline and Hazardous Materials Safety Administration (PHMSA) prefers the ERPG-2 value as specified by the EPA regulations as the endpoint for determining toxic concentrations for LNG plants.<sup>46</sup> The AEGL and ERPG toxic concentrations for the primary toxic components stored and processed onsite are presented in table 4.12.1-1.

TABLE 4.12.1-1						
Toxicity Levels (in ppm) for Various Exposure Times <u>a</u> , <u>b</u>						
		10 min	30 min	60 min	4 hr	8 hr
Ammonia	AEGL 1	30	30	30	30	30
	ERPG 1	-	-	25	-	-
	AEGL 2	220	220	160	110	110
	ERPG 2	-	-	150	-	-
	AEGL 3	2,700	1,600	1,100	550	390
	ERPG 3	-	-	1,500	-	-
Benzene	AEGL 1	130	73	52	18	9
	ERPG 1	-	-	50	-	-
	AEGL 2	2,000	1,100	800	400	200
	ERPG 2	-	-	150	-	-
	AEGL 3	9,700	5,600 <sup>c</sup>	4,000	2,000	990
	ERPG 3	-	-	1,000	-	-
Hexanes	AEGL 1	-	-	-	-	-
	ERPG 1	-	-	None	-	-
	AEGL 2	4,000	2,900	2,900	2,900	2,900
	ERPG 2	-	-	None	-	-
	AEGL 3	12,000 <sup>c</sup>	8,600	8,600	8,600	8,600
	ERPG 3	-	-	None	-	-

<sup>46</sup> RMP toxic endpoints are based on ERPG-2 levels where these levels are available. For substances that do not have established ERPG-2 levels, the toxic endpoint is the level of concern from the EPA's 1987 Technical Guidance for Hazards Analysis.

<b>TABLE 4.12.1-1 (continued)</b>						
<b>Toxicity Levels (in ppm) for Various Exposure Times <u>a</u>, <u>b</u></b>						
		<b>10 min</b>	<b>30 min</b>	<b>60 min</b>	<b>4 hr</b>	<b>8 hr</b>
Hydrogen sulfide	AEGL 1	0.75	0.60	0.51	0.36	0.33
	ERPG 1	-	-	0.1	-	-
	AEGL 2	41	32	27	20	17
	ERPG 2	-	-	30	-	-
	AEGL 3	76	59	50	37	31
	ERPG 3	-	-	100	-	-
Methyl mercaptan	AEGL 1	-	-	-	-	-
	ERPG 1	-	-	0.005	-	-
	AEGL 2	40	29	23	14	7.3
	ERPG 2	-	-	25	-	-
	AEGL 3	120	86	68	43	22
	ERPG 3	-	-	100	-	-
Toluene	AEGL 1	67	67	67	67	67
	ERPG 1	-	-	50	-	-
	AEGL 2	1,400	760	560	310	250
	ERPG 2	-	-	300	-	-
	AEGL 3	10,000	5,200	3,700	1,800	1,400
	ERPG 3	-	-	1,000	-	-
Xylenes	AEGL 1	130	130	130	130	130
	ERPG 1	-	-	None	-	-
	AEGL 2	2,500	1,300	920	500	400
	ERPG 2	-	-	None	-	-
	AEGL 3	7,200	3,600	2,500	1,300	1,000
	ERPG 3	-	-	None	-	-
<b>a</b>	EPA, 2013d					
<b>b</b>	American Industrial Hygiene Association, 2013					
<b>c</b>	≥100%LFL					

In addition, methane (the primary component of LNG) and the refrigerants are classified as simple asphyxiants and may pose extreme health hazards, including death, if inhaled in significant quantities within a limited time. As discussed under “Hazardous Releases,” very cold LNG and refrigerant vapors may also cause freeze burns. However, the locations where high vapor concentrations could cause these cold temperatures and oxygen-deprivation effects would be greatly limited due to the vapor continuously mixing with the warmer air surrounding the spill site. For that reason, exposure and asphyxiation injuries from releases of LNG and refrigerants normally represent negligible risks to the public.

Flammable vapor can develop when the temperature of a flammable substance is above its flash point. This vapor can be ignited wherever its concentration in air is between the LFL and upper flammable limit (UFL). Vapor concentrations above the UFL or below the LFL would not ignite. The flammable properties for the various material components and mixtures stored and processed onsite are tabulated in table 4.12.1-2.

<b>TABLE 4.12.1-2</b>			
<b>Flammable Properties <sup>a</sup></b>			
<b>Material Component</b>	<b>Flash Point</b>	<b>LFL (% vol)</b>	<b>UFL (% vol)</b>
Methane	-283°F	5.0	15.0
Ethylene	-250°F	2.7	36
Ethane	-211°F	3.0	12.5
Propane	-155°F	2.1	9.5
n-Butane	-76°F	1.8	8.5
i-Butane	-105°F	1.8	8.4
n-Pentane	-56°F	1.4	7.8
i-Pentane	-60°F	1.4	7.6
n-Hexane	-7.6°F	1.2	7.5
n-Heptane	30°F	1.05	7.0
Benzene	11°F	1.4	7.1
Toluene	45°F	1.2	7.1
m-Xylene	77°F	1.1	7.0
o-Xylene	75°F	1.1	6.0
p-Xylene	77°F	1.1	7.0
Hydrogen sulfide	-116°F	4.0	44
<b>a</b> Society of Fire Protection Engineers (2008).			

For flammable vapors, the extent of the affected area and the severity of the impacts on objects within a vapor cloud primarily depend on the material, quantity, and duration of the initial release; the surrounding terrain; and the environmental conditions present during the dispersion of the cloud. Although H<sub>2</sub>S is a flammable material, it is present at this facility only in small quantities and mixtures with other materials, and always at concentrations less than its LFL. Therefore, toxicity would be the governing hazard for an H<sub>2</sub>S release. Toxic vapor dispersion distances for the proposed Project are evaluated in section 4.12.1.8.

### **Flammable Vapor Ignition**

If the flammable portion of a vapor cloud encounters an ignition source, the vapor cloud will ignite. Once a vapor cloud is ignited, the flame front may propagate back to the spill site if the vapor concentration along this path is sufficiently high to support the combustion process. In most circumstances, the flame would be driven by the heat it generates. This process is known as a “deflagration,” or a flash fire, because of its relatively short duration. However, exposure to a deflagration can cause severe burns and death, and can ignite combustible materials within the cloud. Flammable vapor dispersion distances for the proposed Project are evaluated in section 4.12.1.7.

If the deflagration in a flammable vapor cloud accelerates to a sufficiently high rate of speed, pressure waves that can cause damage would be generated. As a deflagration accelerates to super-sonic speeds, the large shock waves produced, rather than the heat, would begin to drive the flame, resulting in a detonation. High-speed deflagrations or detonations are generally characterized as explosions, as the rapid movement of the flame and pressure waves associated with them cause additional damage beyond that from the heat. The amount of damage an explosion causes depends on the amount that the produced pressure



wave is above atmospheric pressure (i.e., an overpressure) and its duration (i.e., pulse). For example, a 1 psi overpressure, often cited as a safety limit in U.S. regulations, is associated with glass shattering and the glass pieces traveling with velocities high enough to lacerate skin. The flame speeds primarily depend on the reactivity of the fuel, the ignition strength and location, the degree of congestion and confinement of the area occupied by the vapor cloud, and the flame travel distance. Overpressure hazards for the proposed Project are addressed in section 4.12.1.9, including potential impacts on LNG storage tanks and occupied buildings.

When the flame reaches vapor concentrations above the UFL, the deflagration could transition to a fireball and result in a pool or jet fire back at the source. A fireball would occur near the source of the release and would be of a relatively short duration compared to an ensuing jet or pool fire. The extent of the affected area and the severity of the impacts on objects in the vicinity of a fire would primarily depend on the material, quantity, and duration of the fire; the surrounding terrain; and the environmental conditions present during the fire. Radiant heat hazards for the proposed Project are addressed in section 4.12.1.10.

The heat from a fire may also cause failures of nearby storage vessels, piping, and equipment if not properly mitigated. The failure of a pressurized vessel could cause fragments of material to fly through the air at high velocities, posing damage to surrounding structures and a hazard for operating staff, emergency personnel, or other individuals in proximity to the event. In addition, failure of a pressurized vessel when the liquid is at a temperature significantly above its normal boiling point could result in a boiling-liquid-expanding-vapor explosion (BLEVE). BLEVEs can produce overpressures when the superheated liquid rapidly changes from a liquid to a vapor upon the release from the vessel. BLEVEs of flammable fluids may also ignite upon its release and cause a subsequent fireball. The potential for these hazards are further discussed in section 4.12.1.10.

### **Past Incidents at LNG Plants**

With the exception of the October 20, 1944, failure at an LNG facility in Cleveland, Ohio, the operating history of the U.S. LNG industry has been free of safety-related incidents resulting in adverse effects on the public or the environment. The 1944 incident in Cleveland led to a fire that killed 128 people and injured 200 to 400 more people.<sup>47</sup> The failure of the LNG storage tank was due to the use of materials inadequately suited for cryogenic temperatures. LNG migrating through streets and into underground sewers due to the lack of adequate spill impoundments at the site was also a contributing factor. Current regulatory requirements ensure that proper materials suited for cryogenic temperatures are used and that spill impoundments are designed and constructed properly to contain a spill at the site.

Another operational accident occurred in 1979 at the Cove Point LNG facility in Lusby, Maryland. A pump seal failure resulted in gas vapors entering an electrical conduit and settling in a confined space. When a worker switched off a circuit breaker, the gas ignited, causing heavy damage to the building and a worker fatality. With the participation of the FERC, lessons learned from the 1979 Cove Point accident resulted in changing the national fire codes to better ensure that the situation would not occur again.

On January 19, 2004, a blast occurred at Sonatrach's Skikda, Algeria, LNG liquefaction facility that killed 27 and injured 56 workers. No members of the public were injured. Findings of the accident investigation suggested that a cold hydrocarbon leak occurred at Liquefaction Train 40 and was introduced to the high-pressure steam boiler by the combustion air fan. An explosion developed inside the boiler firebox, which subsequently triggered a larger explosion of the hydrocarbon vapors in the immediate vicinity. The resulting fire damaged the adjacent liquefaction process and liquid petroleum gas separation

---

<sup>47</sup> For a description of the incident and the findings of the investigation, see "U.S. Bureau of Mines, Report on the Investigation of the Fire at the Liquefaction, Storage, and Regasification Plant of the East Ohio Gas Co., Cleveland, Ohio, October 20, 1944," dated February 1946.

equipment of Train 40, and spread to Trains 20 and 30. Although Trains 10, 20, and 30 had been modernized in 1998 and 1999, Train 40 had been operating with its original equipment since start-up in 1981. To ensure that this potential hazard would be addressed for the Golden Pass LNG Export Project, we made a recommendation in section 4.12.1.9 for Golden Pass to provide for our approval the details of mitigation for flammable vapor dispersion and ignition in buildings and combustion equipment.

On March 31, 2014, an internal detonation occurred within a gas heater at Northwest Pipeline Corporation's LNG peak-shaving facility in Plymouth, Washington<sup>48</sup>. This internal detonation subsequently caused the failure of pressurized equipment, resulting in high velocity projectiles. The facility was immediately shut down, and emergency procedures were activated, which included notifying local authorities and evacuating all plant personnel. No members of the public were injured, but one worker was sent to the hospital for injuries. As a result of the incident, the liquefaction trains and a compressor station located onsite were rendered inoperable. Projectiles from the incident also damaged the control building that was located near pre-treatment facilities and penetrated the outer shell of one of the LNG storage tanks. All damaged facilities were ultimately taken out of service for repair. The accident investigation showed that an inadequate purge after maintenance activities resulted in a fuel-air mixture remaining in the system. The fuel-air mixture auto-ignited during startup after it passed through the gas heater at full operating pressure and temperature. To ensure that this potential hazard would be addressed for the Golden Pass LNG Export Project, we included a recommendation in section 4.12.1.3 for Golden Pass to provide a plan for purging that addresses the requirements of the American Gas Association Purging Principles and Practice and to provide justification if not using an inert or non-flammable gas for purging. We also included a recommendation in section 4.12.1.3 for Golden Pass to provide, for review and approval, updates to its existing operating and maintenance plans, including safety procedures, to reflect the LNG Export Project. In order to prevent other sources of projectiles from affecting occupied buildings and storage tanks, we also included recommendations in sections 4.12.1.7 and 4.12.1.9 for the use of additional mitigation to prevent a BLEVE from occurring and for re-evaluating the location or design of the new control building.

#### **4.12.1.3 Technical Review of the Facility Preliminary Engineering Design**

Operation of the proposed facility poses a potential hazard that could affect the public safety if strict design and operational measures to control potential accidents are not applied. The primary concerns are those events that could lead to a hazardous release of sufficient magnitude to create an offsite hazard, as discussed in section 4.12.1.2. However, it is important to recognize the stringent requirements in place for the design, construction, operation, and maintenance of the facility, as well as the extensive safety systems proposed to detect and control potential hazards.

In general, we consider an acceptable design to include various layers of protection or safeguards to reduce the risk of a potentially hazardous scenario from developing into an event that could impact the offsite public. These layers of protection are independent of one another so that any one layer would perform its function regardless of the initiating event or action, or failure of any other protection layer. Such design features and safeguards typically include:

- a facility design that prevents hazardous events through the use of inherently safer designs; suitable materials of construction; operating and design limits for process piping, process vessels, and storage tanks; adequate design for wind, flood, seismic, and other outside hazards;
- control systems, including monitoring systems and process alarms, remotely-operated control and isolation valves, and operating procedures to ensure that the facility stays within the established operating and design limits;

---

<sup>48</sup> For a description of the incident and the findings of the investigation, see Root Cause Failure Analysis, Plymouth LNG Plant Incident Investigation under CP14-515.

- safety instrumented prevention systems, such as safety control valves and emergency shutdown systems, to prevent a release if operating and design limits are exceeded;
- physical protection systems, such as appropriate electrical area classification, proper equipment and building spacing, pressure relief valves, spill containment, and cryogenic, overpressure, and fire structural protection, to prevent escalation to a more severe event;
- site security measures for controlling access to the facility, including security inspections and patrols, response procedures to any breach of security, and liaison with local law enforcement officials; and
- onsite and offsite emergency response, including hazard detection and control equipment, firewater systems, and coordination with local first responders, to mitigate the consequences of a release and prevent it from escalating to an event that could impact the public.

We believe the inclusion of such protection systems or safeguards in a facility design can minimize the potential for an initiating event to develop into an incident that could impact the safety of the offsite public. In addition, siting of the proposed facilities with regard to potential offsite consequences can be further used to minimize impacts on public safety. As discussed in section 4.12.1.4, the DOT's regulations in 49 CFR 193, Subpart B require a siting analysis to be performed by Golden Pass.

As part of its application, Golden Pass provided a front-end-engineering-design (FEED) for the Golden Pass LNG Export Project. FERC staff use this information to assess the safety of the Project. The objectives of our FEED review focused on the engineering design and safety concepts of the various protection layers, as well as the projected operational reliability of the proposed facilities.

In developing the FEED, Golden Pass conducted a hazard identification (HAZID) study of the preliminary design to identify potential risk scenarios. The HAZID identified potential hazards for the process area, operating area, and adjacent spaces and considered the consequences of these hazards. The study also identified the safeguards that would be in place to prevent or mitigate the hazard and proposed recommendations as needed to eliminate, prevent, control, or mitigate the hazards.

Golden Pass states that all process facilities would be designed to withstand a sustained wind speed of 150 mph, which Golden Pass equates to a 183-mph wind gust for 3 seconds.<sup>49</sup> Golden Pass also notes that the design wind speed applied at the liquefaction facilities would correspond to a strong Category 4 hurricane (on the Saffir-Simpson hurricane scale), which has sustained wind speeds ranging from 130 to 156 mph.

The existing LNG terminal is enclosed within a storm surge protection barrier that rises to an elevation of 16 feet (NAVD 88). Golden Pass would extend this 16-foot-tall barrier to surround the proposed Golden Pass LNG Export Project facilities, which would be constructed on land areas with typical elevations between approximately 5 and 8 feet. Based on the Preliminary Jefferson County Flood Insurance Study (2012), the storm surge protection barrier would provide a minimum of 2 feet of freeboard over the 100-year storm surge, including wave crests. For a 500-year return period storm in the same study corresponding to a weak Category 4 hurricane, the still water elevation for the storm surge would be from 0.5 to 1.7 feet below the top of the levee. However, the wave crest elevation could be up to 4 feet above the levee top. Water could potentially fill the facility, submerging equipment located on the ground. In

---

<sup>49</sup> A 150-mph sustained wind speed would correspond to a 183-mph 3-second gust using the Durst Curve in American Society of Civil Engineers (ASCE) 7-05 and a 185-mph 3-second gust using a 1.23 gust factor for onshore winds at a coast line recommended in World Meteorological Organization, *Guidelines for Converting between Various Wind Averaging Periods in Tropical Cyclone Conditions*. These wind speeds are equivalent to approximately a 14,000-year mean return interval or 0.36 percent probability of exceedance in a 50-year period for the site, based on ASCE 7-05 wind speed return period conversions.

preparation for the storm, Golden Pass would safely shutdown process operations. Golden Pass indicated that the five existing LNG storage tanks with outer concrete walls have only top penetrations; therefore, flowline damage should not release LNG from those tanks. However, stored diesel and other chemical liquids could be released if their storage vessels were compromised as a result of wave overtopping and flooding of the facility. Where possible, appropriate, and with sufficient transportation assets available, Golden Pass personnel would void the chemical tanks to prevent a release. The potential release of hazardous substances in this situation would not be expected to create a significant public hazard, because a storm of such intensity would require a mandatory evacuation of the surrounding community. Storm surge is also discussed in section 4.1.4.1, "Flooding/Storm Surge/Tsunamis." In addition, sections 4.1.3 and 4.1.6 discuss FERC staff's examination of the seismic and structural design of the facilities.

The closest airport to the Golden Pass Project site is the Jack Brookes Regional Airport, which is approximately 14 miles away. The proposed liquefaction facilities may include equipment taller than 200 feet. Therefore, the regulations in 14 CFR 77 may apply to that equipment and require Golden Pass to provide notice to the FAA of its proposed construction. The FERC would need a final determination from the FAA that the proposed facilities would not pose a hazard to air navigation. Therefore, **we recommend that:**

- **Prior to the end of the draft EIS comment period, Golden Pass should file with the Secretary documentation demonstrating it has filed for an Aeronautical Study under 14 CFR 77.**
- **Prior to initial site preparation, Golden Pass should file with the Secretary final determinations made by the FAA indicating that there would be no hazard to aircraft from the proposed LNG terminal facilities.**

The design specifies materials of construction and ratings suited to the pressure and temperature conditions of the process design. Piping would be designed, fabricated, assembled, erected, inspected, examined, and tested in accordance with the American Society of Mechanical Engineers (ASME) Standards B31.3, B31.5, B36.10, and B36.19. Pressure vessels would be designed, fabricated, inspected, examined, and tested in accordance with ASME Boiler and Pressure Vessel Code (BPVC) Section VIII per 49 CFR 193 and the NFPA 59A (2001 edition). Low-pressure storage tanks such as the amine storage tank and condensate storage tank would be designed in accordance with the API Standards 620 and 650. Heat exchangers would be designed to ASME BPVC Section VIII standards; API Standards 660, 661, and 662; and the Tubular Exchanger Manufacturers Association (TEMA) standards. Rotating equipment would be designed to standards and recommended practices, such as API Standards 610, 613, 614, 616, 617, 618, 619, 670, 671, 672, 675, 676, 682, and 686; and ASME Standards B73.1 and B73.2. Valves would be designed to standards and recommended practices such as API Standards 589, 594, 598, 600, 601, 602, 607, and 609; ASME Standards 16.5, 16.10, 16.20, 16.25, and 16.34; and ISA Standards 75.01.01, 75.08.01, and 75.08.05.

Golden Pass would install process control valves and instrumentation to safely operate and monitor the facility. Alarms would have visual and audible notification in the control room to warn operators that process conditions may be approaching design limits. Operators would have the capability to take action from the control room to mitigate an upset. Golden Pass would develop facility operation procedures after completion of the final design; this timing is fully consistent with accepted industry practice. Golden Pass would design their control systems and human machine interfaces (HMI) to the International Society for Automation (ISA) Standards 5.3, 5.5, 60.1, 60.3, 60.4, and 60.6, and other standards and recommended practices. We have made recommendations for Golden Pass to provide more information on the operating and maintenance procedures as they are developed, including safety procedures, hot work procedures and permits, abnormal operating conditions procedures, and personnel training. In addition, we have recommended measures such as labeling of instrumentation and valves, piping, and equipment and car-

seals/locks to address human factor considerations and improve facility safety. An alarm management program in accordance with ISA Standard 18.2 would also be in place to ensure the effectiveness of the alarms.

Safety valves and instrumentation would be installed to monitor, alarm, shut down, and isolate equipment and piping during process upsets or emergency conditions. Safety-instrumented systems would comply with ISA Standard 84.01 and other recommended and generally accepted good engineering practices. We also made recommendations on the final design, installation, and commissioning of instrumentation and emergency shutdown equipment to ensure appropriate cause-and-effect alarm or shutdown logic and enhanced representation of the emergency shutdown valves in the facility control system.

Safety relief valves and flares would be installed to protect the process equipment and piping. The safety relief valves would be designed to handle process upsets and thermal expansion within piping, per NFPA 59A (2001 edition) and ASME Section VIII; and would be designed in accordance with API Standards 520, 521, and 527 (2000 requirements); ASME Standards B31.3 and B31.5; and other recommended and generally accepted good engineering practices. In addition, we made recommendations to ensure that the design and installation of pressure and vacuum relief devices are adequate.

The security requirements for the proposed Project are governed by 33 CFR 105, 33 CFR 127, and 49 CFR 193, Subpart J – Security.

Requirements for maintaining security can also be found in the Coast Guard's 33 CFR 127 regulations. Title 33 CFR 105, as authorized by the Marine Transportation Security Act, requires all terminal owners and operators to submit a Facility Security Assessment and a Facility Security Plan to the Coast Guard for review and approval. Some of the responsibilities of the applicant include, but are not limited to:

- designating a Facility Security Officer with a general knowledge of current security threats and patterns, security assessment methodology, vessel and facility operations, conditions, security measures, emergency preparedness, response, and contingency plans, who would be responsible for implementing the Facility Security Assessment and Facility Security Plan and performing an annual audit for the life of the Project;
- conducting a Facility Security Assessment to identify site vulnerabilities, possible security threats and consequences of an attack, and facility protective measures; developing a Facility Security Plan based on the Facility Security Assessment, with procedures for: responding to transportation security incidents; notification and coordination with federal, state, and local authorities; prevention of unauthorized access; measures to prevent or deter entrance with dangerous substances or devices; training; and evacuation;
- defining the security organizational structure with facility personnel with knowledge or training in current security threats and patterns; recognition and detection of dangerous substances and devices, recognition of characteristics and behavioral patterns of persons who are likely to threaten security; techniques to circumvent security measures; emergency procedures and contingency plans; operation, testing, calibration, and maintenance of security equipment; and inspection, control, monitoring, and screening techniques;
- implementing scalable security measures to provide increasing levels of security at increasing maritime security levels for facility access control, restricted areas, cargo handling, vessel stores and bunkers, and monitoring; ensuring that the Transportation Worker Identification Credential program is properly implemented;

- ensuring coordination of shore leave for vessel personnel or crew change out as well as access through the facility for visitors to the vessel;
- conducting drills and exercises to test the proficiency of security and facility personnel on a quarterly and annual basis; and
- reporting all breaches of security and transportation security incidents to the National Response Center.

Under 33 CFR 105, Golden Pass would be required to submit an updated Facility Security Plan to the Coast Guard for review and approval before commencement of operations of the proposed Project facilities. Golden Pass would also be required to control and restrict access, patrol and monitor the facility, detect unauthorized access, and respond to security threats or breaches under Title 33 CFR 105. Title 33 CFR 127 also has requirements for access controls, lighting, security systems, security personnel, protective enclosures, communications, and emergency power.

Title 49 CFR 193 Subpart J also specifies security requirements for the onshore component of LNG facilities, including requirements for conducting security inspections and patrols, liaison with local law enforcement officials, design and construction of protective enclosures, lighting, monitoring, alternative power sources, and warning signs.

Golden Pass must comply with all of the requirements specified in the Coast Guard and the DOT regulations and has proposed to provide additional qualified security personnel, access control systems, lighting, security cameras, intrusion detection systems, communication systems, and emergency power. Golden Pass also indicated adherence to ISA Standards 99.01.01 and 99.02.01.

In the event of a release, sloped areas under storage and process facilities would direct a spill away from equipment and into the impoundment system. This arrangement would minimize the dispersion of flammable vapors into confined, occupied, or public areas and minimize the potential for heat from a fire to impact adjacent equipment, occupied buildings, or public areas if ignition were to occur. The spacing of vessels and equipment between each other, from ignition sources, and to the property line would meet the requirements of NFPA Standards 30 and 59A (2001 edition) as referenced in 49 CFR 193.2401.

Golden Pass performed a preliminary fire protection evaluation to ensure that adequate hazard detection, hazard control, and firewater coverage would be installed to detect and address any flammable releases. Structural fire protection to prevent failure of structural supports of equipment and pipe racks would comply with NFPA 59A (2001 edition) and other recommended and generally accepted good engineering practices. Golden Pass would also install hazard detection systems to detect, alarm, and alert personnel in the area and control room to initiate an emergency shutdown and/or initiate appropriate procedures, and would meet NFPA Standard 72, ISA Standard 12.13, and other recommended and generally accepted good engineering practices. Hazard control devices would be installed to extinguish or control incipient fires and releases, and would meet NFPA 59A; NFPA 10, 11, 12, 15, 17, and 2001; API 2030, 2218, and 2510A; as well as other recommended and generally accepted good engineering practices. Golden Pass would provide firewater systems, including monitors for use during an emergency to cool the surface of storage vessels, piping, and equipment exposed to heat from a fire, and would meet NFPA 59A, 13, 14, 15, 20, 22, 24, 25, 307, and 1961 requirements. We have made recommendations for Golden Pass to provide a final fire protection evaluation and more information on the final design, installation, and commissioning of hazard detection, hazard control, and firewater systems as Golden Pass would further develop this information during the final design phase.

Golden Pass would also have emergency procedures in accordance with 49 CFR 193 and 33 CFR 127. The emergency procedures would provide for the protection of personnel and the public as well as the prevention of property damage that may occur as a result of incidents at the facility. Golden Pass would

also be required to update its ERP in accordance with the EPCRA 2005, as discussed further in section 4.12.1.7.

As a result of the technical review of the information provided by Golden Pass in the submittal documents, we identified a number of concerns in an information request letter issued on April 16, 2015, relating to the reliability, operability, and safety of the proposed design. Golden Pass provided written responses to the information requests on May 5, 2015. Some of these responses indicated that Golden Pass would correct or modify its design in order to address issues raised in the information request. As a result, **we recommend that:**

- **The final design shall provide information/revisions pertaining to Golden Pass' response numbers 6, 9, 10, 11, 16, 19, 23, 24, 25, 26, 27, 28, 29, 30, 38, 40, and 43 of its May 5, 2015 filing, which indicated features to be included or considered in the final design.**

The FEED and specifications submitted for the proposed facilities to date are preliminary but would serve as the basis for any detailed design to follow. If authorization is granted by the Commission, the next phase of the proposed Project would include development of the final design, including final selection of equipment manufacturers, process conditions, and resolution of some safety-related issues. We do not expect that the detailed design information to be developed would result in changes to the basis of design, operating conditions, major equipment selections, equipment design conditions, or safety system designs that were presented as part of the FEED.

A more detailed and thorough hazard and operability review (HAZOP) analysis would be performed by Golden Pass during the final design phase to identify the major hazards that may be encountered during the operation of facilities. The HAZOP study would be intended to address hazards of the process, engineering and administrative controls and would provide a qualitative evaluation of a range of possible safety, health, and environmental effects that may result from the design or operation of the facility. Recommendations to prevent or minimize these hazards would be generated from the results of the HAZOP review. We have included a recommendation that Golden Pass should file the HAZOP study on the completed final design.

Once the design has been subjected to a HAZOP review, the design development team tracks changes in the facility design, operations, documentation, and personnel. Golden Pass would evaluate these changes to ensure that the safety, health, and environmental risks arising from these changes are addressed and controlled. Resolutions of the recommendations generated by the HAZOP review would be monitored by the FERC staff.

Information regarding the development of the final design, as detailed below, would need to be filed with the Secretary, for review and written approval by the Director of OEP, before equipment construction at the site would be authorized. To ensure that the concerns we have identified relating to the reliability, operability, and safety of the proposed design are addressed by Golden Pass, and to ensure that the facility is subject to the Commission's construction and operational inspection program, **we recommend that the following measures should apply to the Golden Pass LNG Export Project. Information pertaining to these specific recommendations should be filed with the Secretary, for review and written approval by the Director of OEP, either prior to initial site preparation, prior to construction of final design, prior to commissioning, prior to introduction of hazardous fluids, or prior to commencement of service, as indicated by each specific condition. Specific engineering, vulnerability, or detailed design information meeting the criteria specified in Order No. 683 (Docket No. RM06-24-000), including security information, should be submitted as critical energy infrastructure information pursuant to 18 CFR 388.112. See Critical Energy Infrastructure Information, Order No. 683, 71 Fed. Reg. 58,273 (October 3, 2006), FERC Stats. & Regs. ¶31,228 (2006). Information pertaining to items such as offsite emergency response, procedures for public**

notification and evacuation, and construction and operating reporting requirements would be subject to public disclosure. All information should be filed a minimum of 30 days before approval to proceed is requested.

- **Prior to initial site preparation**, Golden Pass should file an overall Project schedule, which includes the proposed stages of the commissioning plan.
- **Prior to initial site preparation**, Golden Pass should provide quality assurance and quality control procedures for construction activities.
- **Prior to initial site preparation**, Golden Pass should provide procedures for controlling access during construction.
- The **final design** should include change logs that list and explain any changes made from the FEED provided in Golden Pass' application and filings. A list of all changes with an explanation for the design alteration should be provided and all changes should be clearly indicated on all diagrams and drawings.
- The **final design** should provide a plot plan of the final design showing all major equipment, structures, buildings, and impoundment systems.
- The **final design** should provide an up-to-date complete equipment list, process and mechanical data sheets, and specifications.
- The **final design** should include three-dimensional plant drawings to confirm plant layout for maintenance, access, egress, and congestion.
- The **final design** should provide up-to-date Process Flow Diagrams with heat and material balances and Piping and Instrumentation Diagrams (P&ID), which include the following information:
  - a. equipment tag number, name, size, duty, capacity, and design conditions;
  - b. equipment insulation type and thickness;
  - c. storage tank pipe penetration size and nozzle schedule;
  - d. valve high pressure side and internal and external vent locations;
  - e. piping with line number, piping class specification, size, and insulation type and thickness;
  - f. piping specification breaks and insulation limits;
  - g. all control and manual valves numbered;
  - h. relief valves with size and set points; and
  - i. drawing revision number and date.
- The **final design** should provide P&IDs, specifications, and procedure that clearly show and specify the tie-in details required to safely connect the Golden Pass LNG Export Project to the existing Golden Pass Import Terminal.
- The **final design** should include a list of all car-sealed and locked valves consistent with the P&IDs.
- The **final design** should include a hazard and operability review of the completed design prior to issuing the P&IDs for construction. A copy of the review, a list of recommendations, and actions taken on the recommendations, should be filed.



- The **final design** should include the cause-and-effect matrices for the process instrumentation, fire and gas detection system, and emergency shutdown system. The cause-and-effect matrices should include alarms and shutdown functions, details of the voting and shutdown logic, and set points.
- The **final design** should include an analysis of the system for draining the LNG loading and circulating lines that clearly demonstrates that the LNG drain drums (11-MBD69001 and 12-MBD69001) are correctly sized for the surge events and that the emergency shutdown system will prevent overflow of LNG into the boil off system.
- The **final design** of all molecular sieve beds should specify the blowdown conditions required to be taken into consideration when sizing the molecular sieve support system.
- The **final design** should ensure that the LNG storage tank piping supports are adequately designed for the higher rated in-tank pump flow rates.
- The **final design** should demonstrate that, for hazardous fluids, piping and piping nipples 2 inches or less in diameter are designed to withstand external loads, including vibrational loads in the vicinity of rotating equipment and operator live loads in areas accessible by operators.
- The **final design** should include the sizing basis and capacity for the final design of the flares and/or vent stacks as well as the pressure and vacuum relief valves for major process equipment, vessels, and storage tanks.
- The **final design** should include drawings and details of how process seals or isolations installed at the interface between a flammable fluid system and an electrical conduit or wiring system meet the requirements of NFPA 59A (2001 edition).
- The **final design** should provide an air gap or vent installed downstream of process seals or isolations installed at the interface between a flammable fluid system and an electrical conduit or wiring system. Each air gap should vent to a safe location and be equipped with a leak detection device that should continuously monitor for the presence of a flammable fluid, alarm the hazardous condition, and shut down the appropriate systems.
- The **final design** should provide electrical area classification drawings.
- The **final design** should specify that all emergency shutdown valves are to be equipped with open and closed position switches connected to the Distributed Control System /Safety Instrumented System.
- The **final design** should include a drawing showing the location of the emergency shutdown buttons. Emergency shutdown buttons should be easily accessible, conspicuously labeled, and located in an area which would be accessible during an emergency.
- The **final design** should include an updated fire protection evaluation of the proposed facilities carried out in accordance with the requirements of NFPA 59A (2001 edition), Chapter 9.1.2 as required by 49 CFR 193. A copy of the evaluation, a list of recommendations and supporting justifications, and actions taken on the recommendations should be filed. Specific consideration should be given to the use of low expansion foam and other automatic fire protection measures in the condensate and hazardous fluid storage areas.

- The **final design** should provide detailed calculations to confirm that the final fire water volumes would be accounted for when evaluating the capacity of the impoundment system during a spill and fire scenario.
- The **final design** should provide spill containment system drawings with dimensions and slopes of curbing, trenches, and impoundments, as well as the sizing and design of the down-comer that would transfer spills from the tank top to the ground-level impoundment system.
- The **final design** should provide complete drawings and a list of the hazard detection equipment. The drawings should clearly show the location and elevation of all detection equipment. The list should include the instrument tag number, type and location, alarm indication locations, and shutdown functions of the hazard detection equipment.
- The **final design** should include a list of alarm and shutdown set points for all hazard detectors that account for the calibration gas when determining the lower flammability limit set points for methane, propane, and ethylene, and condensate.
- The **final design** should include a list of alarm and shutdown set points for all hazard detectors that account for the calibration gas when determining the toxic concentration set points for condensates, ammonia, and hydrogen sulfide.
- The **final design** should provide complete plan drawings and a list of the fixed and wheeled, dry-chemical, and hand-held fire extinguishers, and other hazard control equipment. Drawings should clearly show the location by tag number of all fixed, wheeled, and hand-held extinguishers. The list should include the equipment tag number, type, capacity, equipment covered, discharge rate, and automatic and manual remote signals initiating discharge of the units.
- The **final design** should provide facility plans and drawings that show the location of the firewater and foam systems. Drawings should clearly show: firewater and foam piping; post indicator valves; and the location, and area covered by, each monitor, hydrant, deluge system, foam system, water-mist system, and sprinkler. The drawings should also include piping and instrumentation diagrams of the firewater and foam system.
- The **final design** should provide the procedures for pressure/leak tests which address the requirements of ASME VIII and ASME B31.3.
- The **final design** should include a plan for clean-out, dry-out, purging, and tightness testing. This plan should address the requirements of the American Gas Association's Purging Principles and Practice required by 49 CFR 193, and should provide justification if not using an inert or non-flammable gas for clean-out, dry-out, purging, and tightness testing.
- **Prior to commissioning**, Golden Pass should provide a detailed schedule for commissioning through equipment startup. The schedule should include milestones for all procedures and tests to be completed: prior to introduction of hazardous fluids and during commissioning and startup. Golden Pass should file documentation certifying that each of these milestones has been completed before authorization to commence the next phase of commissioning and startup will be issued.
- **Prior to commissioning**, Golden Pass should file plans and detailed procedures for testing the integrity of onsite mechanical installation, functional tests, introduction of hazardous fluids, operational tests, and placing the equipment into service.

- **Prior to commissioning**, Golden Pass should tag all equipment, instrumentation, and valves in the field, including drain valves, vent valves, main valves, and car-sealed or locked valves.
- **Prior to commissioning**, Golden Pass should file a tabulated list and drawings of the proposed hand-held fire extinguishers. The list should include the equipment tag number, extinguishing agent type, capacity, number, and location. The drawings should show the extinguishing agent type, capacity, and tag number of all hand-held fire extinguishers.
- **Prior to commissioning**, Golden Pass should file updates, addressing the Golden Pass LNG Export Project facilities, in the existing operation and maintenance procedures and manuals, as well as safety procedures.
- **Prior to commissioning**, Golden Pass should maintain a detailed training log to demonstrate that operating staff has completed the required training.
- **Prior to introduction of hazardous fluids**, Golden Pass should complete all pertinent tests (Factory Acceptance Tests, Site Acceptance Tests, Site Integration Tests) associated with the Distributed Control System and the Safety Instrumented System that demonstrates full functionality and operability of the system.
- **Prior to introduction of hazardous fluids**, Golden Pass should complete a firewater pump acceptance test and firewater monitor and hydrant coverage test. The actual coverage area from each monitor and hydrant should be shown on facility plot plan(s).
- **Prior to commencement of service**, Golden Pass should update procedures for off-site contractors' responsibilities, restrictions, and limitations and for supervision of these contractors by Golden Pass staff.
- **Prior to commencement of service**, Golden Pass should label piping with fluid service and direction of flow in the field, in addition to the pipe labeling requirements of NFPA 59A (2001 edition).
- **Prior to commencement of service**, Golden Pass should notify the FERC staff of any proposed revisions to the security plan and physical security of the facility.
- **Prior to commencement of service**, progress on the construction of the proposed systems should be reported in monthly reports filed with the Secretary. Details should include a summary of activities, problems encountered, contractor non-conformance/deficiency logs, remedial actions taken, and current Project schedule. Problems of significant magnitude should be reported to the FERC within 24 hours.

In addition, we recommend that the following measures should apply throughout the life of the Golden Pass LNG Export Project facilities:

- The facility should be subject to regular FERC staff technical reviews and site inspections on at least an annual basis or more frequently as circumstances indicate. Prior to each FERC staff technical review and site inspection, Golden Pass should respond to a specific data request, including information relating to possible design and operating conditions that may have been imposed by other agencies or organizations. Up-to-date detailed piping and instrumentation diagrams reflecting facility modifications and provision of other pertinent information not included in the semi-annual reports described below, including facility events that have taken place since the previously submitted semi-annual report, should be submitted.

- **Semi-annual operational reports should be filed with the Secretary to identify changes in facility design and operating conditions; abnormal operating experiences; activities (e.g., ship arrivals, quantity and composition of imported and exported LNG, liquefied and vaporized quantities, boil off/flash gas); and plant modifications, including future plans and progress thereof. Abnormalities should include, but not be limited to, unloading/loading/shipping problems, potential hazardous conditions from offsite vessels, storage tank stratification or rollover, geysering, storage tank pressure excursions, cold spots on the storage tanks, storage tank vibrations and/or vibrations in associated cryogenic piping, storage tank settlement, significant equipment or instrumentation malfunctions or failures, non-scheduled maintenance or repair (and reasons therefore), relative movement of storage tank inner vessels, hazardous fluids releases, fires involving hazardous fluids and/or from other sources, negative pressure (vacuum) within a storage tank, and higher than predicted boil off rates. Adverse weather conditions and the effect on the facility also should be reported. Reports should be submitted within 45 days after each period ending June 30 and December 31. In addition to the above items, a section entitled “Significant Plant Modifications Proposed for the Next 12 Months (dates)” should be included in the semi-annual operational reports. Such information would provide the FERC staff with early notice of anticipated future construction/maintenance at the LNG export Project facilities.**
- **Significant non-scheduled events, including safety-related incidents (e.g., LNG, condensate, refrigerant, or natural gas releases; fires; explosions; mechanical failures; unusual over pressurization; and major injuries) and security-related incidents (e.g., attempts to enter site, suspicious activities) should be reported to the FERC staff. In the event that an abnormality is of significant magnitude to threaten public or employee safety, cause significant property damage, or interrupt service, notification should be made immediately, without unduly interfering with any necessary or appropriate emergency repair, alarm, or other emergency procedure. In all instances, notification should be made to the FERC staff within 24 hours. This notification practice should be incorporated into the LNG facility’s emergency plan. Examples of reportable hazardous fluids-related incidents include:**
  - a. **fire;**
  - b. **explosion;**
  - c. **estimated property damage of \$50,000 or more;**
  - d. **death or personal injury necessitating in-patient hospitalization;**
  - e. **release of hazardous fluids for 5 minutes or more;**
  - f. **unintended movement or abnormal loading by environmental causes, such as an earthquake, landslide, or flood, that impairs the serviceability, structural integrity, or reliability of an LNG facility that contains, controls, or processes hazardous fluids;**
  - g. **any crack or other material defect that impairs the structural integrity or reliability of an LNG facility that contains, controls, or processes hazardous fluids;**
  - h. **any malfunction or operating error that causes the pressure of a pipeline or LNG facility that contains or processes hazardous fluids to rise above its maximum allowable operating pressure (or working pressure for LNG facilities) plus the build-up allowed for operation of pressure-limiting or control devices;**

- i. a leak in an LNG facility that contains or processes hazardous fluids that constitutes an emergency;
- j. inner tank leakage, ineffective insulation, or frost heave that impairs the structural integrity of an LNG storage tank;
- k. any safety-related condition that could lead to an imminent hazard and cause (either directly or indirectly by remedial action of the operator), for purposes other than abandonment, a 20 percent reduction in operating pressure or shutdown of operation of a pipeline or an LNG facility that contains or processes hazardous fluids;
- l. safety-related incidents to hazardous fluids vessels occurring at or en route to and from the LNG facility; or
- m. an event that is significant in the judgment of the operator and/or management even though it did not meet the above criteria or the guidelines set forth in an LNG facility's incident management plan.

**In the event of an incident, the Director of OEP has delegated authority to take whatever steps are necessary to ensure operational reliability and to protect human life, health, property, or the environment, including authority to direct the LNG facility to cease operations. Following the initial company notification, the FERC staff would determine the need for a separate follow-up report or follow up in the upcoming semi-annual operational report. All company follow-up reports should include investigation results and recommendations to minimize a reoccurrence of the incident.**

In addition to the final design review, we would conduct inspections during construction and would review additional materials, including quality assurance and quality control plans, nonconformance reports, and cooldown and commissioning plans, to ensure that the installed design is consistent with the safety and operability characteristics of the FEED. We would also conduct inspections during operation to ensure that the facility is operated and maintained in accordance with the filed design throughout the life of the facility. Based on our analysis and the recommendations presented above, we believe that the Project FEED would include acceptable layers of protection or safeguards which would reduce the risk of a potentially hazardous scenario from developing into an event that could impact the offsite public.

#### **4.12.1.4 Siting Requirements for the Proposed Facilities**

The principal hazards associated with the Golden Pass LNG Export Project would result from potential cryogenic and flashing liquid releases, flammable and toxic vapor dispersion, vapor cloud ignition, pool and jet fires, BLEVEs, and overpressures. As discussed in section 4.12.1.3, our FEED review indicates that sufficient layers of protection would be incorporated into the facility design to mitigate the potential for an initiating event to develop into an incident that could impact the safety of the offsite public. Siting of the facilities with regard to potential offsite consequences is also required by the DOT's regulations in 49 CFR 193, Subpart B to ensure that impact on the public would be minimized. The Commission's regulations under 18 CFR 380.12(o)(14) require Golden Pass to identify how the proposed design complies with the siting requirements of the DOT's regulations in 49 CFR 193, Subpart B. As part of our review, we used Golden Pass' information, developed to comply with the DOT's regulations, to assess whether the facility would impact public safety. The Part 193 requirements state that an operator or government agency must exercise control over the activities that can occur within an "exclusion zone," defined as the area around an LNG facility that could be exposed to specified levels of thermal radiation or flammable vapor in the event of a release. Approved mathematical models must be used to calculate the dimensions of these exclusion zones. The 2001 edition of NFPA 59A, an industry consensus safety standard for the siting, design, construction, operation, maintenance, and security of LNG facilities, is incorporated into Part 193

by reference, with regulatory preemption in the event of conflict. The following sections of Part 193 specifically address the siting requirements applicable to each LNG container and LNG transfer system:

- Part 193.2001 (b)(3), Scope of part, excludes any matter other than siting provisions pertaining to marine cargo transfer systems between the marine vessel and the last manifold or valve immediately before a storage tank;
- Part 193.2051, Scope, states that each LNG facility designed, replaced, relocated, or significantly altered after March 31, 2000, must be provided with siting requirements in accordance with Subpart B and NFPA 59A (2001 edition). In the event of a conflict with NFPA 59A (2001 edition), the regulatory requirements in Part 193 prevail;
- Part 193.2057, Thermal radiation protection, requires that each LNG container and LNG transfer system have thermal exclusion zones in accordance with Section 2.2.3.2 of NFPA 59A (2001 edition); and
- Part 193.2059, Flammable vapor-gas dispersion protection, requires that each LNG container and LNG transfer system have a dispersion exclusion zone in accordance with Sections 2.2.3.3 and 2.2.3.4 of NFPA 59A (2001 edition).

For the Golden Pass LNG Export Project, these Part 193 siting requirements would be applicable to the following equipment:

- ten 8,800-gpm in-tank pumps (two higher-rated pumps per existing LNG storage tank) and associated piping and appurtenances – Parts 193.2057 and 2059 require thermal and flammable vapor exclusion zones. NFPA 59A (2001 edition) Section 2.2.3.2 specifies the thermal exclusion zones, and Sections 2.2.3.3 and 2.2.3.4 specify the flammable vapor exclusion zones based on design spills; and
- six 6,900-gpm LNG Product Rundown Pumps and associated piping and appurtenances, including three 18-inch-diameter LNG rundown lines – Parts 193.2057 and 2059 require thermal and flammable vapor exclusion zones. NFPA 59A (2001 edition) Section 2.2.3.2 specifies the thermal exclusion zones, and Section 2.2.3.4 specifies the flammable vapor exclusion zones based on design spills.

Previous FERC environmental assessments/impact statements for past projects have identified inconsistencies and areas of potential conflict between the requirements in Part 193 and NFPA 59A (2001 edition). Sections 193.2057 and 193.2059 require exclusion zones for each LNG container and LNG transfer system; an “LNG transfer system” is defined in Section 193.2007 to include cargo transfer system and transfer piping, and does not distinguish between permanent or temporary. However, NFPA 59A (2001 edition) requires exclusion zones only for “transfer areas,” defined as the part of the plant where the facility introduces or removes the liquids, such as truck loading or ship-unloading areas. The NFPA 59A (2001 edition) definition does not include permanent plant piping, such as cargo transfer lines. Section 2.2.3.1 of NFPA 59A (2001 edition) also states that transfer areas at the water edge of marine terminals are not subject to the siting requirements in that standard.

The DOT has addressed some of these issues in a March 2010 letter of interpretation. For flammable vapors, the extent of the affected area and the severity of the impacts on objects within a vapor cloud would primarily depend on the material, quantity, and duration of the initial release; the surrounding terrain; and the environmental conditions present during the dispersion of the cloud. Although H<sub>2</sub>S is a flammable material, it is present at this facility only in small quantities and in mixtures with other materials, and always at concentrations less than its LFL. Therefore, toxicity would be the governing hazard for a release of H<sub>2</sub>S. Vapor dispersion distances for the proposed Project are evaluated in section 4.12.1.8.

In its 2010 letter, the DOT stated that (1) the requirements in the NFPA 59A (2001 edition) for transfer areas for LNG apply to the marine cargo transfer system at a proposed waterfront LNG facility, except where preempted by the regulations in Part 193; (2) the regulations in Part 193 for LNG transfer systems conflict with NFPA 59A (2001 edition) on whether an exclusion zone analysis is required for transfer piping or permanent plant piping; and (3) the regulations in Part 193 prevailed as a result of that conflict. The DOT has determined that an exclusion zone analysis of the marine cargo transfer system is required.

In FERC environmental assessments/impact statements for past projects, we have also noted that when the DOT incorporated NFPA 59A into its regulations, it removed the regulation that required impounding systems around transfer piping. As a result of that change, it is unclear whether Part 193 or the adopted sections of NFPA 59A (2001 edition) require impoundments for LNG transfer systems. We believe that Part 193 requires exclusion zones for LNG transfer systems, and that those zones were historically calculated based on impoundment systems. We also believe that the omission of containment for transfer piping is not a sound engineering practice. For these reasons, we consider it prudent design practice to provide containment for all LNG transfer piping within a plant's property lines.

Federal regulations issued by the Occupational Safety and Health Administration (OSHA) under 29 CFR 1910.119, *Process Safety Management of Highly Hazardous Chemicals* (PSM), and the EPA under 40 CFR 68, *Chemical Accident Prevention Provisions* cover hazardous substances such as methane, propane, and ethylene at many facilities in the United States. However, the OSHA and EPA regulations are not applicable to facilities regulated under 49 CFR 193. On October 30, 1992, shortly after the promulgation of the OSHA PSM regulations, OSHA issued a letter of interpretation that precluded the enforcement of PSM regulations over gas transmission and distribution facilities. In a subsequent letter on December 9, 1998, OSHA further clarified that this letter of interpretation applies to LNG distribution and transmission facilities.

In addition, EPA's preamble to its final rule in Federal Register, Volume 63, Number 3, 639 645, clarified that exemption from the requirements in 40 CFR 68 for regulated substances in transportation, including storage incident to transportation, is not limited to pipelines. The preamble further clarified that the transportation exemption applies to LNG facilities subject to oversight or regulation under 49 CFR 193, including facilities used to liquefy natural gas or used to transfer, store, or vaporize LNG in conjunction with pipeline transportation. Therefore, the above OSHA and EPA regulations are not applicable to facilities regulated under 49 CFR 193. As stated in Section 193.2051, LNG facilities must be provided with the siting requirements of NFPA 59A (2001 edition). The siting requirements for flammable liquids within an LNG facility are contained in NFPA 59A, Chapter 2:

- NFPA 59A (2001 edition) Section 2.1.1 requires consideration of clearances between flammable refrigerant storage tanks, flammable liquid storage tanks, structures, and plant equipment, both with respect to plant property lines and each other. This section also requires that other factors applicable to the specific site that have a bearing on the safety of plant personnel and surrounding public be considered, including an evaluation of potential incidents and safety measures incorporated into the design or operation of the facility.
- NFPA 59A (2001 edition) Section 2.2.2.2 requires impoundments serving flammable refrigerants or flammable liquids to contain a 10-minute spill of a single accidental leakage source or during a shorter time period based upon demonstrable surveillance and shutdown provisions acceptable to the DOT. In addition, NFPA Section 2.2.2.5 requires impoundments and drainage channels for flammable liquid containment to conform to NFPA 30, *Flammable and Combustible Liquids Code*.

- NFPA 59A (2001 edition) Section 2.2.3.2 requires provisions to minimize the damaging effects of fire from reaching beyond a property line, and requires provisions to prevent a radiant heat flux level of 1,600 Btu/ft<sup>2</sup>-hr from reaching beyond a property line that can be built upon. The distance to this flux level is to be calculated with LNGFIRE or using models that have been validated by experimental test data appropriate for the hazard to be evaluated and that are acceptable to the DOT.
- NFPA 59A (2001 edition) Section 2.2.3.4 requires provisions to minimize the possibility of any flammable mixture of vapors from a design spill from reaching a property line that can be built upon and that would result in a distinct hazard. Determination of the distance that the flammable vapors extend is to be determined with DEGADIS or alternative models that take into account physical factors influencing LNG vapor dispersion. Alternative models must have been validated by experimental test data appropriate for the hazard to be evaluated and must be acceptable to the DOT. NFPA 59A (2001 edition) Section 2.2.3.5 requires the design spill for impounding areas serving vaporization and process areas to be based on the flow from any single accidental leakage source.

The above siting requirements from Part 193 and NFPA 59A (2001 edition) would be applicable to the following Project facilities:

- all piping and equipment associated with the pre-treatment and liquefaction processes;
- all piping and equipment associated with the storage and trucking of refrigerants, condensates and other hazardous fluids; and
- all impoundment systems serving hazardous fluids.

#### **4.12.1.5 Impoundment Sizing**

Under NFPA 59A (2001 edition) Section 2.2.2.2, the capacity of impounding areas for vaporization, process, or LNG transfer areas must equal the greatest volume that can be discharged from any single accidental leakage source during a 10-minute period or during a shorter time period based upon demonstrable surveillance and shutdown provisions acceptable to the DOT. We consider it prudent design practice to size impoundments based on the greatest flow capacity from a single pipe for 10 minutes or the capacity of the largest vessel served, whichever is greater, while recognizing that different spill scenarios may be used for the single accidental leakage sources for the hazard calculations required by Part 193.

Potential spills from the existing 36-inch-diameter ship loading header would be directed to the existing Tank Area Containment Sump. Although this header was constructed previously, the discharge from the larger proposed in-tank pumps would flow through this line. The sizing spill from the ship loading header for the proposed Project would be a full guillotine failure at the pump run out rates of the larger proposed in-tank pumps for 10 minutes. This results in a sizing spill of 862,962 gallons. As discussed in the final EIS for the Golden Pass LNG Terminal and Pipeline Project (Docket No. CP04-386), the Tank Area Containment Sump has dimensions of 150 feet by 50 feet by 11 feet of usable depth and has a usable capacity of 617,143 gallons under the trough intersection. However, information provided by Golden Pass on September 25, 2015, indicates that the existing sump dimensions include an extra 5 feet above that height, potentially allowing for a total 897,662-gallon volume plus the trough system, to adequately contain the sizing spill. Information provided by Golden Pass on October 21, 2015, indicates that this sump may be even deeper. We included a recommendation to provide as-built drawings.

The troughs appear to be 5 feet deep with variable widths, but the slopes of the trough system have not been fully clarified for the FERC staff. In addition, Golden Pass should determine whether the liquid



volume inside the piping system would be de-inventoried within the spill duration minus the typical valve closure time. Therefore, **we recommend that:**

- **Prior to the end of the draft EIS comment period, Golden Pass should file with the Secretary:**
  - a. **an evaluation of the spill time needed to de-inventoried the largest isolatable section around a ship loading header sizing spill;**
  - b. **as-built drawings for the existing Tank Area Containment Sump, depicting the overall dimensions and the height of the trough intersection;**
  - c. **trough system drawings defining the specific trough slopes, along with the trough sizing philosophy for the Project; and**
  - d. **a detailed analysis of the areas that the sizing spill for the Tank Area Containment Sump would reach after exceeding that sump's usable volume underneath the trough intersection.**

The Trains 1–3 Process Area Sump would contain an LNG or refrigerant spill from any of the three liquefaction trains. The dimensions of the Trains 1–3 Process Area Sump would be 55 feet by 55 feet, with a depth of 10 feet below the trough intersection. This provides a usable sump capacity of 226,286 gallons. The largest sizing spill to the Trains 1–3 Process Area Sump would result from the rupture of an individual LNG rundown line. Golden Pass estimated this volume to be 82,104 gallons, which includes 10 minutes at a minimum of 120 percent design flow to account for pump run out. The Trains 1–3 Process Area Sump would be adequately sized to contain a spill from an LNG rundown line.

The Truck Loading LNG Spill Containment Sump would contain spills from LNG truck loading operations. Golden Pass designed this sump to hold 110 percent volume of one 8,000-gallon truck, totaling 8,800 gallons. The dimensions of the Truck Loading LNG Spill Containment Sump would be 10 feet by 10 feet with a depth of 15 feet under the trough intersection, which provides a usable sump capacity of 11,221 gallons. This sump would be adequately sized to contain a spill from a full LNG truck with an 8,000-gallon capacity. However, larger LNG delivery trucks of up to 13,000 gallons are being used and sold in the United States; therefore, **we recommend that:**

- **Prior to the end of the draft EIS comment period, Golden Pass should file with the Secretary an indication of whether it would limit truck deliveries to those with a maximum capacity not exceeding the impoundment capacity or whether it would accommodate larger trucks and supply a larger impoundment capacity.**

The Refrigerant Storage Area Sump would contain spills from the propane, ethylene, and off-spec condensate storage systems. The dimensions of the Refrigerant Storage Sump would be 50 feet by 50 feet with a usable depth of 20 feet, providing a sump capacity of 374,026 gallons. The largest sizing spill to the Refrigerant Storage Area Sump would result from loss of containment of a propane storage vessel with a capacity of 242,510 gallons. Golden Pass indicates that the Refrigerant Storage Area Sump would be adequately sized to contain 110 percent of the contents of a full propane vessel, or 266,761 gallons, even though the entire contents may not remain liquid during a release scenario.

The amine make-up, amine drain collector, aqueous ammonia, and hydrocarbon condensate storage vessels would have their own dedicated impoundment systems to contain 110 percent of the vessel capacity, as listed in table 4.12.1-3. Golden Pass indicated that all containment areas serving hazardous liquid vessels would be sized to contain 110 percent of the volume of the vessel instantaneously.

TABLE 4.12.1-3			
Impoundment Area Sizing			
Largest Sizing Spill Source	Spill Size (gallons)	Impoundment System	Impoundment Size (gallons)
36-inch Ship Loading Header	862,962	Tank Area Containment Sump	see text discussion (617,143-897,662)
18-inch LNG Rundown Line	82,104	Trains 1–3 Process Area Sump	226, 286
LNG Truck	see text discussion (8,800-13,000)	Truck Loading LNG Spill Containment Sump	11,221
Propane Storage Vessel	266,761	Refrigerant Storage Area Sump	374,026
Amine Drain Collector	3,860	Amine Area Sump	101,735
Condensate Storage Vessel	96,941	Condensate Storage Tank Spill Containment Area	109,964
Make-up Amine Storage Tank	174,504	Amine Storage Tank Spill Containment Area	201,880
Aqueous Ammonia Storage Vessel	80,992	Ammonia Storage Vessel Spill Containment Area	92,291

Table 4.12.1-3 lists the governing sizing spill volumes and their corresponding impoundment systems.

Golden Pass has not yet provided sizing spills for all sumps that could contain hazardous liquids and has not clarified the usable volume of sumps that would have tanks within them. Therefore, we recommend that:

- Prior to the end of the draft EIS comment period, Golden Pass should file with the Secretary, as public information, sizing spills for the diesel area, nitrogen, oil, ammonia day tanks, thermal oxidizer/flare, compressor turbine drives, and any other sumps that could contain flammable or potentially toxic fluids. Golden Pass should include the detailed dimensions and usable volumes for all hazardous fluid sumps that would have tank(s) within them, including for liquid nitrogen. Golden Pass should also include a detailed explanation of how hydrocarbon condensate releases in the process area would be contained.**

#### 4.12.1.6 Design Spills

Design spills are used in the determination of the hazard calculations required by Part 193. Prior to the incorporation of NFPA 59A in 2000, the design spill in Part 193 assumed the full rupture of “a single transfer pipe which has the greatest overall flow capacity” for not less than 10 minutes (old Part 193.2059[d]). With the adoption of NFPA 59A, the basis for the design spill for impounding areas serving only vaporization, process, or LNG transfer areas became the flow from any single accidental leakage source. Neither Part 193 nor NFPA 59A (2001 edition) define “single accidental leakage source.”

In a letter to the FERC staff, dated August 6, 2013, the DOT requested that LNG facility applicants contact the Office of Pipeline Safety’s Engineering and Research Division regarding the Part 193 siting

requirements.<sup>50</sup> Specifically, the letter stated that the DOT required a technical review of the applicant's design spill criteria for single accidental leakage sources on a case-by-case basis to determine compliance with Part 193.

In response, Golden Pass provided the DOT with its design spill criteria and identified leakage scenarios for the proposed equipment. The DOT reviewed the data and methodology Golden Pass used to determine the single accidental leakage sources for the design spills, which were based on the flow from various leakage sources including piping, containers, and equipment containing LNG, refrigerants, and other hazardous fluids. On June 11, 2015, the DOT provided a letter to the FERC staff stating that the DOT had no objection to Golden Pass' methodology for determining the single accidental leakage sources for candidate design spills to be used in establishing the Part 193 siting requirements for the proposed facilities.<sup>51</sup> The design spills produced by this method were identified in the documents reviewed by the DOT and have been filed in the FERC docket for this Project. These are the same design spills described in the following sections.

The DOT's conclusions on the candidate design spills used in the siting calculations required by Part 193 were based on preliminary design information which may be revised as the engineering design progresses. If Golden Pass' design or operation of the proposed facilities differs from the details provided in the documents on which the DOT based its review, the facilities may not comply with the siting requirements of Part 193. As a result, **we recommend that:**

- **Golden Pass should certify that the final design is consistent with the information provided to the DOT as described in the design spill determination letter dated June 11, 2015 (Accession Number 20150616-5185). In the event that any modification to the design alters the candidate design spills on which the 49 CFR 193 siting analysis was based, Golden Pass should consult with the DOT on any actions necessary to comply with Part 193.**

A different subset of design spills would be applicable to each type of hazard. Therefore, the specific design spills used for each part of the Golden Pass LNG Export Project siting analysis are listed in the applicable section, including "Flammable Vapor Dispersion Analysis," "Overpressure Analysis," "Toxic Dispersion Analysis," and "Thermal Radiation Analysis."

#### **4.12.1.7 Flammable Vapor Dispersion Analysis**

As discussed in section 4.12.1.2, a large quantity of flammable material released without ignition would form a flammable vapor cloud that would travel with the prevailing wind until it dispersed below the flammable limit or encountered an ignition source. To address these hazards, 49 CFR 193.2051 and 193.2059 require an evaluation of both vapor dispersion from potential incidents and vapor dispersion exclusion zones in accordance with applicable sections of NFPA 59A (2001 edition). Taken together, Part 193 and NFPA 59A (2001 edition) require that flammable vapors either from an LNG tank impoundment or a single accidental leakage source do not extend beyond areas in which the operator or a government agency legally controls all activities. In addition, NFPA 59A Section 2.1.1 requires that factors applicable to the specific site with a bearing on the safety of plant personnel and surrounding public be considered, including an evaluation of potential incidents and safety measures incorporated into the design or operation of the facility. NFPA 59A Section 2.2.3.4 also requires provisions to minimize the possibility of any

---

<sup>50</sup> August 6, 2013 letter from Kenneth Lee, Director of Engineering and Research Division, Office of Pipeline Safety to Terry Turpin, LNG Engineering and Compliance Branch, Office of Energy Projects. Filed in Docket No. PF13-14 on August 13, 2013. Accession Number 20130813-4015.

<sup>51</sup> June 11, 2015 letter "Re: Golden Pass Products, LLC, FERC Docket No. CP14-517-000, Design Spill Determination" from Kenneth Lee to Terry L. Turpin. Filed in Docket Number CP14-517 on June 16, 2015. Accession Number 20150616-5185.

flammable mixture of vapors from a design spill reaching a property line that can be built upon and that would result in a distinct hazard.

Title 49 CFR 193.2059 requires that dispersion distances be calculated for a 2.5 percent average gas concentration (one-half the LFL of LNG vapor) under meteorological conditions that result in the longest downwind distances at least 90 percent of the time. Alternatively, maximum downwind distances may be estimated for stability Class F, a wind speed of 4.5 mph, 50 percent relative humidity, and the average regional temperature. Similar factors to account for model uncertainty (i.e., one-half the LFL of other flammable materials) and parameters (i.e., Class F stability, 2 meters/second [m/sec] wind speed, 50 percent relative humidity, average regional temperature, and 0.03 meter [m] surface roughness) have also been specified for other hazardous fluids.

The regulations in Part 193 specifically approve the use of two models for performing these dispersion calculations: DEGADIS and FEM3A. The use of alternative models is also allowed but must be specifically approved by the DOT. Although Part 193 does not require the use of a particular source term model, modeling of the spill and resulting vapor production is necessary prior to the use of vapor dispersion models. In August 2010, the DOT issued Advisory Bulletin ADB-10-07 to provide guidance on obtaining approval of alternative vapor-gas dispersion models under Subpart B of 49 CFR 193. In October 2011, two dispersion models were approved by the DOT for use in vapor dispersion exclusion zone calculations: PHAST-UDM Version 6.6 and Version 6.7 (submitted by Det Norske Veritas) and FLACS Version 9.1 Release 2 (submitted by GexCon). Golden Pass used PHAST 6.7 and FLACS 9.1, with their built-in source term models, to calculate dispersion distances.

As discussed under “Design Spills,” failure scenarios must be selected as the basis for the Part 193 dispersion analyses. Process conditions at the failure location would affect the resulting vapor dispersion distances. In determining the spill conditions for these leakage sources, process flow diagrams for the proposed design, used in conjunction with the heat and material balance information (i.e., flow, temperature, and pressure), can be used to estimate the flow rates and process conditions at the location of the spill. In general, higher flow rates would result in larger spills and longer dispersion distances, higher temperatures would result in higher rates of flashing, and higher pressures would result in higher rates of jetting and aerosol formation that may be located far away from the sump. Therefore, two different pressure scenarios may be considered for each design spill:

1. The pressure in the line is assumed to be maintained by pumps and/or hydrostatic head to produce the highest rate of flashing and jetting (i.e., flashing and jetting scenario).
2. The pressure in the line is assumed to be depressurized by the breach and/or emergency shutdowns to produce the highest rate of liquid flow within a curbed, trenched, or impounded area (i.e., liquid scenario).

Alternatively, a single scenario for each design spill could be selected if adequately supported with an assessment of the depressurization calculations and/or an analysis of process instrumentation and shutdown logic acceptable to the DOT.

In addition, the location and orientation of the leakage source must be considered. The closer a leakage source is to the property line, the higher the likelihood that the vapor cloud would extend offsite. As most flashing and jetting scenarios would not have appreciable liquid rainout and accumulation, the siting of impoundment systems would be driven by liquid scenarios, while siting of piping and other remaining portions of the plant would be driven by flashing and jetting scenarios.

Golden Pass reviewed multiple releases for the liquid scenarios and for the flashing and jetting scenarios. Golden Pass used the following conditions for the vapor dispersion calculations: ambient temperature of 70.0°F, relative humidity of 50 percent, wind speeds of 1-2 m/sec in various directions,

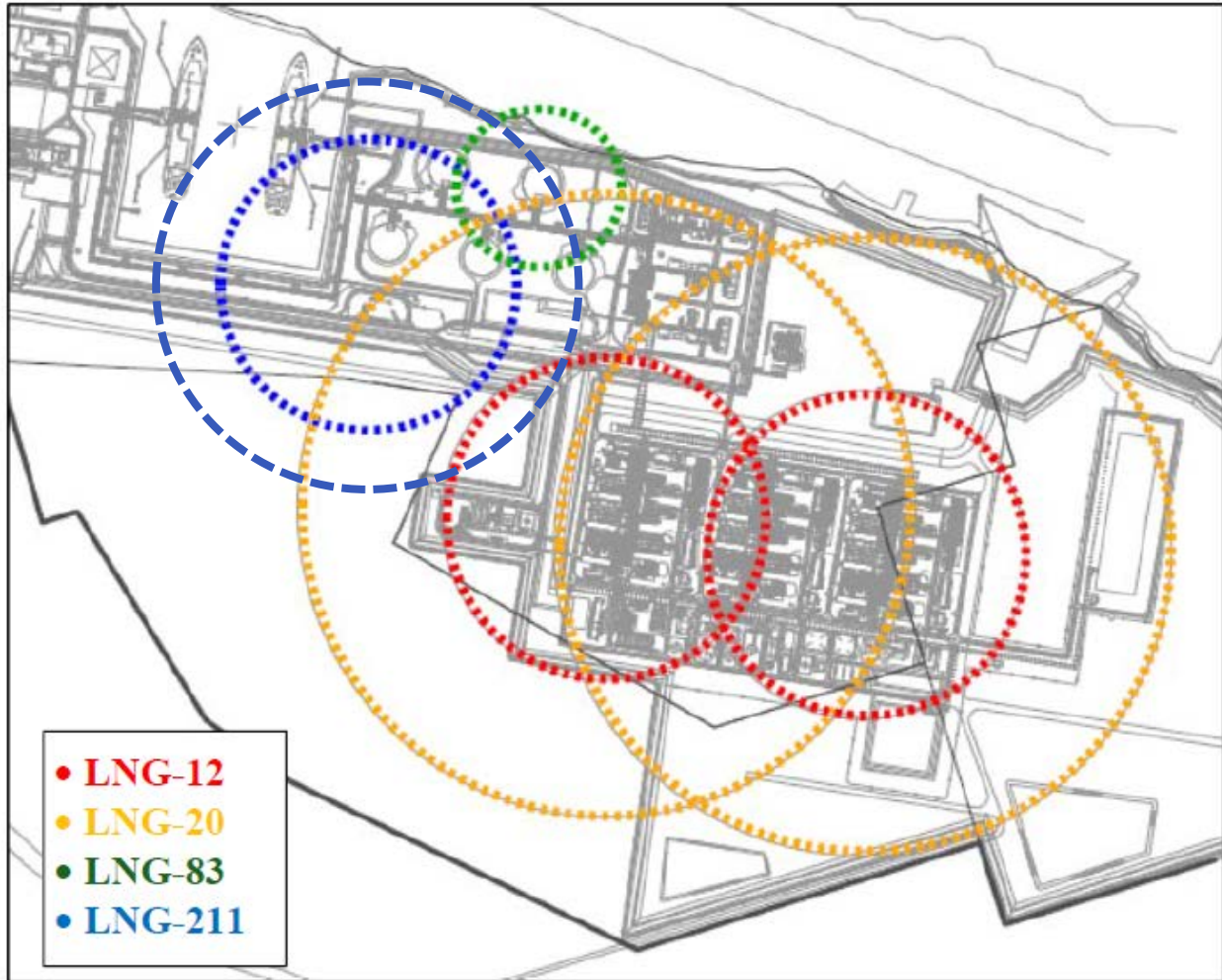
atmospheric stability class of F, and a ground surface roughness of 0.03 m. In addition, a sensitivity analysis for wind speed, and for FLACS wind directions, was provided to demonstrate the longest predicted downwind dispersion distances, as discussed in the PHAST and FLACS Final Decisions.

### Flammable Vapor Dispersion Design Spill Analyses for LNG

The design spill selection methodology discussed under “Design Spills” was applied to the LNG facilities to determine the flashing and jetting design spill cases that would produce the greatest LNG vapor flow rate in each area of the plant. The results are presented in table 4.12.1-4.

<b>Scenario</b>	<b>Location</b>	<b>Hole Diameter (inches)</b>	<b>Line Diameter (inches)</b>	<b>Liquid Rainout (%)</b>	<b>Total Vapor Flow Rate (lb/hr)</b>
LNG-12	LNG liquefaction area	2	20	0	564,142
LNG-20	LNG liquefaction area	4	4	1	2,256,571
LNG-52	LNG rundown line – <i>max liquid</i>	18	18	100	0
LNG-52	LNG rundown line – <i>max vapor horizontal release</i>	7	18	96	74,490
LNG-52	LNG rundown line – <i>max vapor vertical release</i>	7	18	0	1,886,541
LNG-83	LNG storage area	1	24	0	60,683
LNG-211(1)	LNG truck loading	2.5	3	73	49,130
LNG-211(2)	LNG truck loading	3	3	96	81,458

With exception of Scenario LNG-52, all LNG scenarios were modeled using PHAST. The FERC staff performed its own hole-sensitivity analysis for the LNG truck loading scenario LNG-211(2) that resulted in a larger rainout percentage and a larger vapor flow rate. The PHAST modeling results, shown in figure 4.12.1-1, demonstrate that the flammable dispersion, modeled to one-half the LFL, would not extend over a property line that could be built upon.

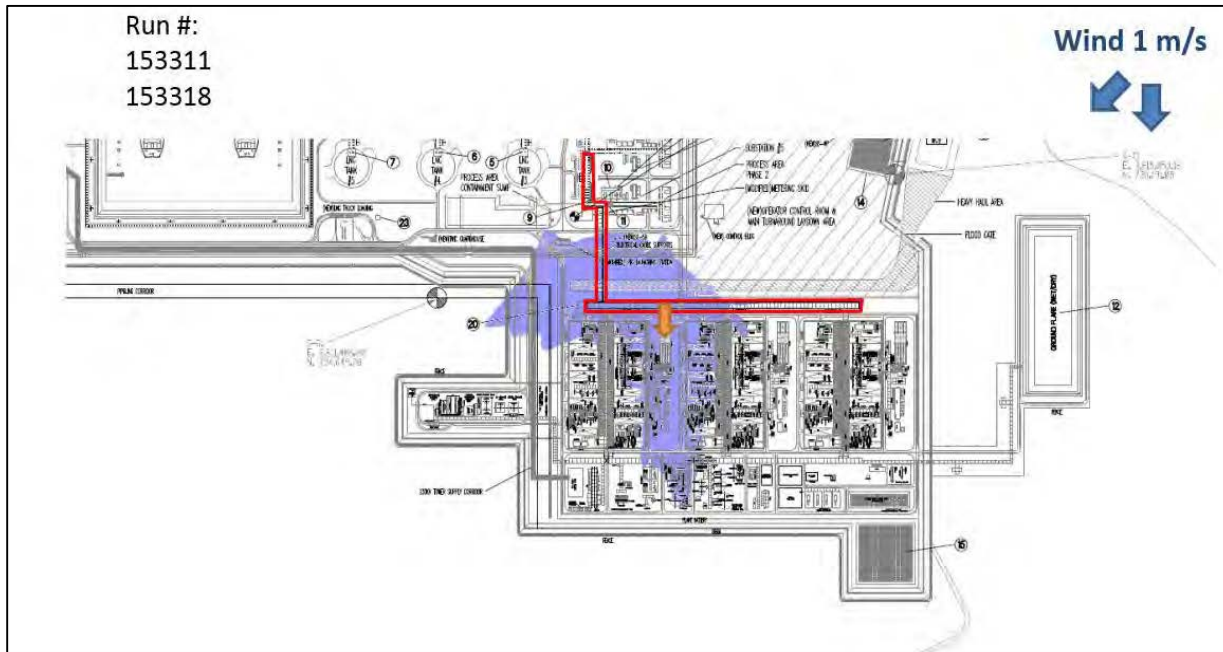


**Figure 4.12.1-1 Maximum Flammable Vapor Dispersion from LNG Scenarios 12, 20, 83 and 211(1) AND 211(2) (*property line shown in bold*)**

FLACS was used to model the vapor dispersion from scenario LNG-52, because FLACS can account for mitigation features and facility geometry within the dispersion cloud. Golden Pass proposes to install a series of 8-foot-high vapor barriers centered vertically along the sides of the elevated LNG rundown line from the liquefaction trains to the tie-in point of the existing facility, which is near the LNG storage tanks. This vapor barrier is represented by a red line in figures 4.12.1-2 and 4.12.1-3. Other 12-foot-high vapor barriers would be installed along the north shore of the terminal site, shown as a green line in figure 4.12.1-4, and additionally along the south side of the plant, shown as yellow lines in figure 4.12.1-5. All of the vapor barriers would have a porosity of 10 percent. The vapor barriers would be designed to the requirements of 49 CFR 193.2067.

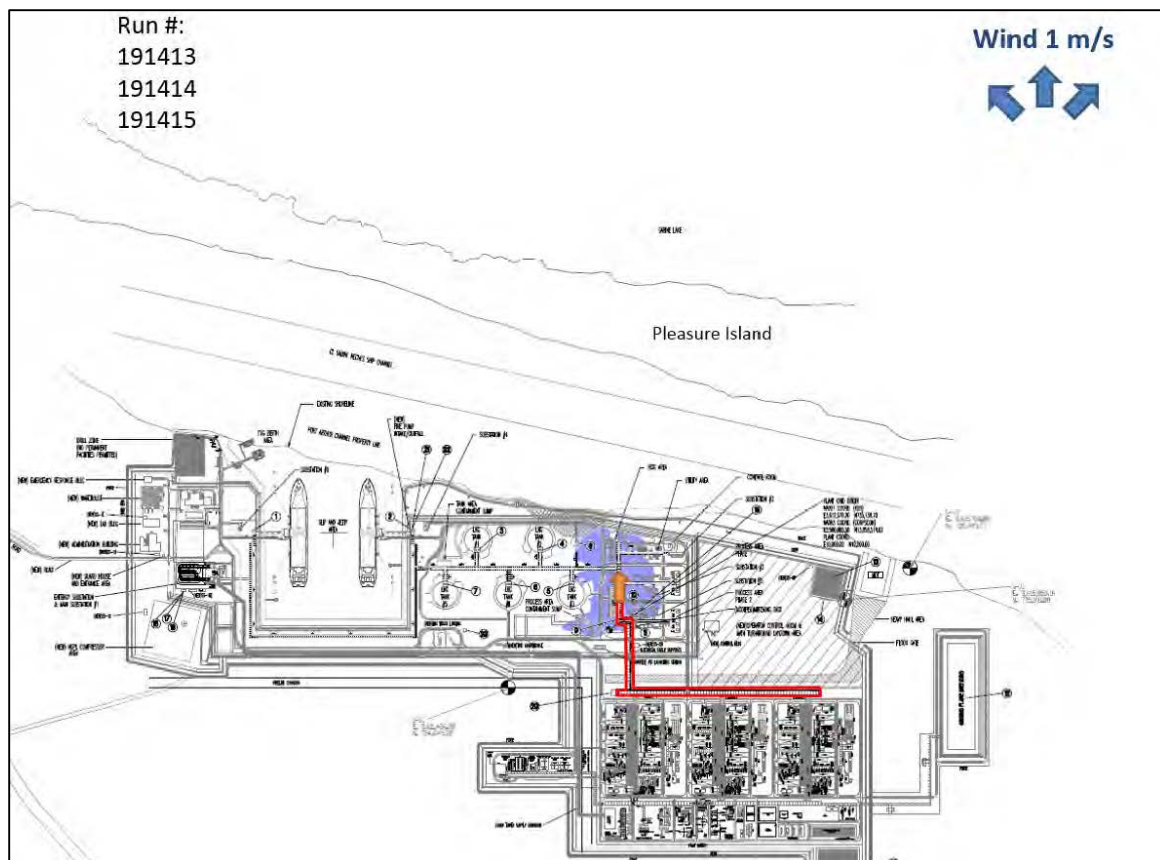
The release points for scenario LNG-52 were chosen at Liquefaction Trains 1 and 3, as well as the tie-in point with the existing facility. Both horizontal and vertical release orientations were considered. The air cooler operation, which could pull dense vapor upward, causing cloud dilution, was not included. In addition, differing wind speeds and directions were modeled to determine the most significant dispersion distances. The releases were initiated after sufficient time had passed in the model simulations to allow the

wind profile to stabilize from effects due to the presence of buildings and other onsite obstructions. Figures 4.12.1-2 and 4.12.1-3 show the maximum extent of the one-half LFL vapor dispersion for horizontal releases from scenario LNG-52.



**Figure 4.12.1-2** Maximum Flammable Vapor Dispersion from LNG Scenario 52 Released Horizontally toward the South (*8-foot-high vapor fences shown as red lines*)





**Figure 4.12.1-3 Maximum Flammable Vapor Dispersion for LNG Scenario 52 Released Horizontally to the North (8-foot-high vapor fences shown as red lines)**

The figures show that the one-half LFL dispersion from horizontal LNG design spills from the rundown line would remain within the facility property boundary. However, because the vapor barriers are close to the horizontal release, the percentage of liquid rainout should be confirmed using a computational fluid dynamics model appropriate for performing those calculations with an obstacle in close range. Therefore, **we recommend that:**

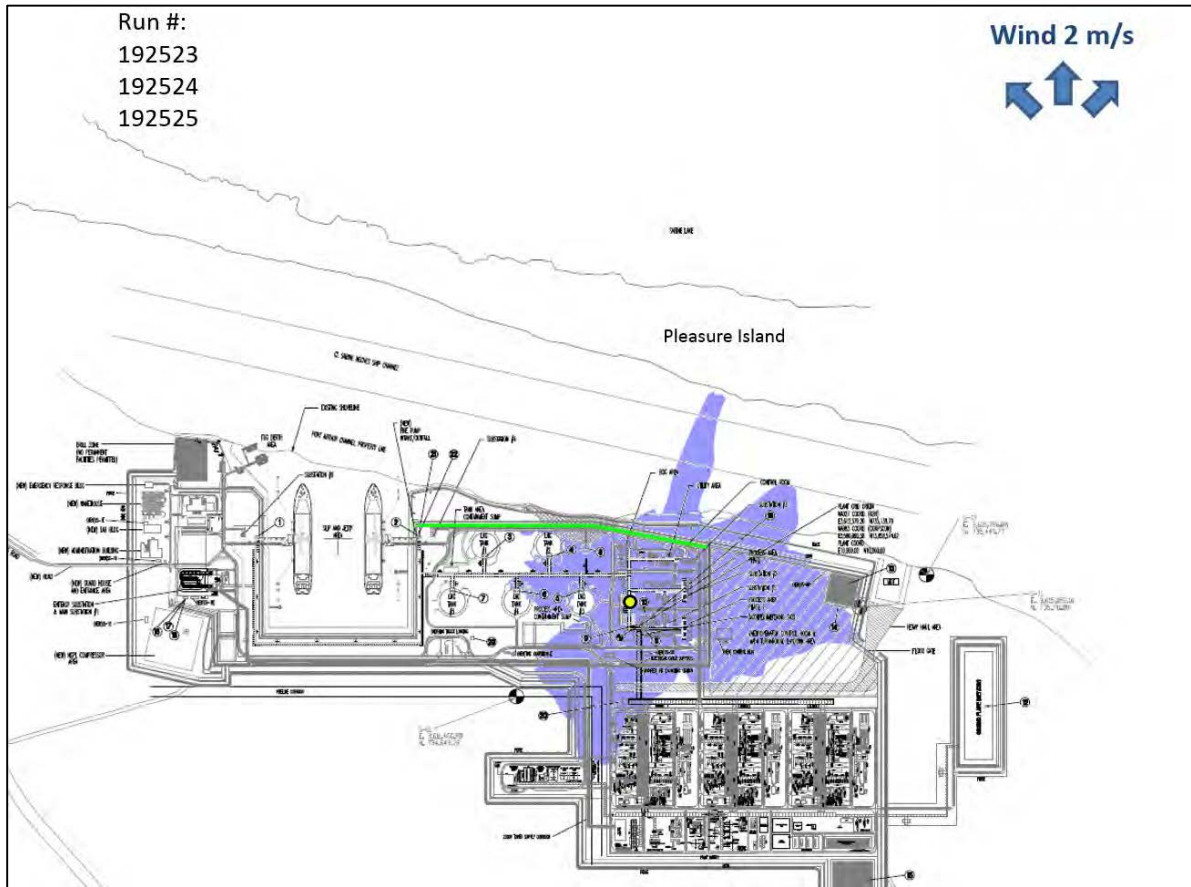
- **Prior to initial site preparation, Golden Pass should file a comparative analysis to support the rainout results using a computational fluid dynamics model that is able to account for the presence of the pipe rack barriers.**

In addition, the mechanical forces and thermal effects of the release onto the barrier have not been confirmed for the FERC staff, therefore **we recommend that:**

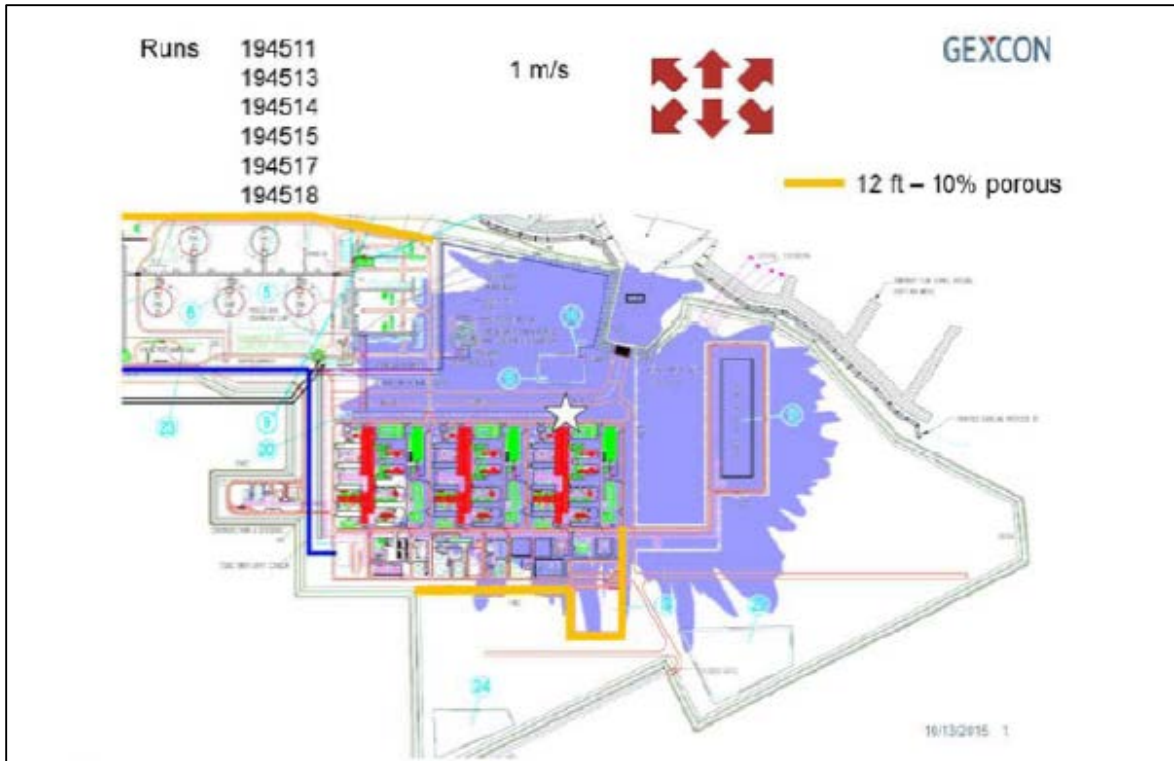
- **The final design should provide the design details of the pipe rack vapor barriers for the rundown line, along with a demonstration that the thermal effects and mechanical forces from a design spill release would not compromise these barriers.**



For vertical releases of scenario LNG-52, the vapor dispersion would be mitigated in some areas by the vapor barriers installed near edges of the plant. Due to the proposed installation of these vapor barriers, the one-half LFL vapor dispersion in these cases would not extend over a property line that could be built upon, as shown in figures 4.12.1-4 and 4.12.1-5.



**Figure 4.12.1-4 Maximum Flammable Vapor Dispersion from LNG Scenario 52 Released Vertically near the Northern End of the Rundown Line (12-foot-high vapor barrier shown in green)**



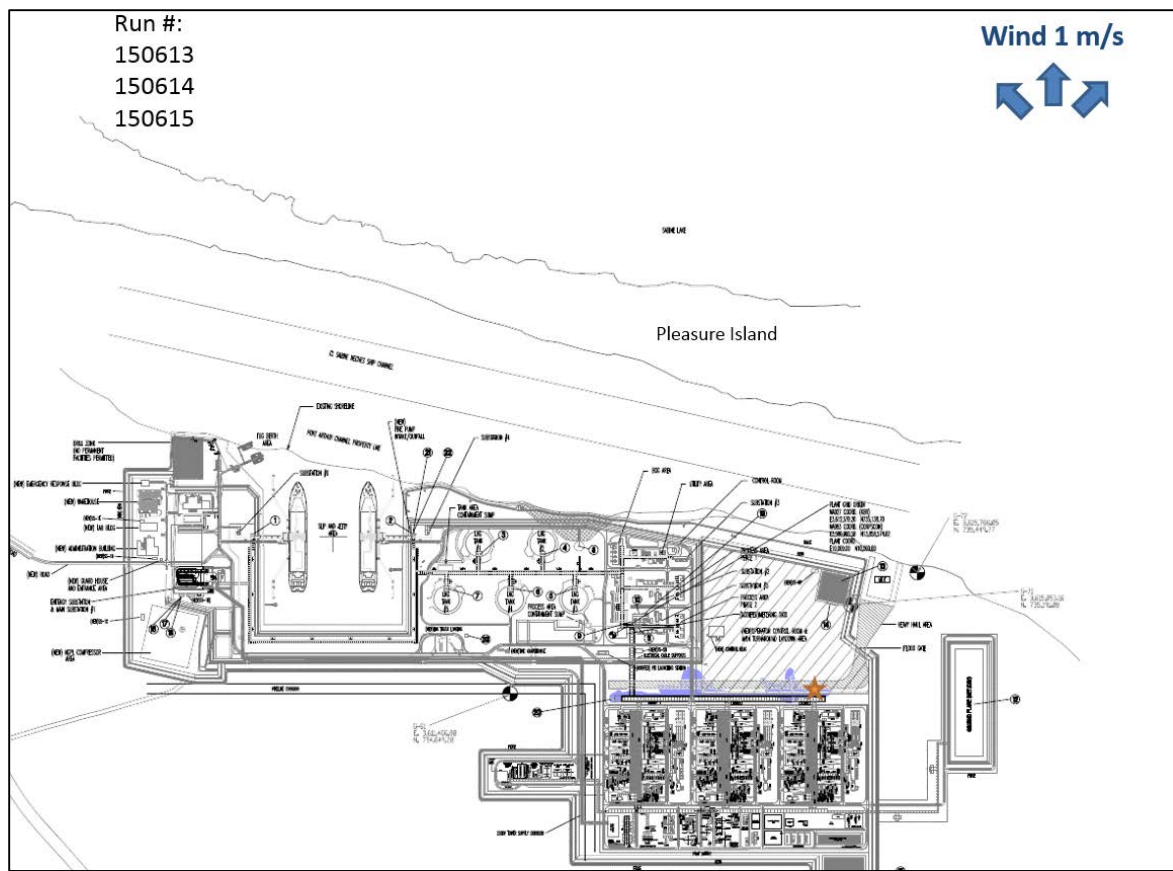
**Figure 4.12.1-5 Maximum Flammable Vapor Dispersion from LNG Scenario 52 Released Vertically near the Southeastern End of the Rundown Line (12-foot-high vapor barriers shown in yellow)**

The proposed vapor barriers would be necessary for compliance with the flammable vapor dispersion requirements in 49 CFR 193.2059. To ensure the integrity of the vapor barriers throughout the life of the facility, Golden Pass indicated that a visual inspection would be conducted, at a minimum, on a weekly basis for metal vapor barriers or after a tropical storm or hurricane. For concrete barriers or soil-filled berms that contribute to vapor dispersion mitigation, the inspection would occur once every quarter year or after a tropical storm or hurricane.

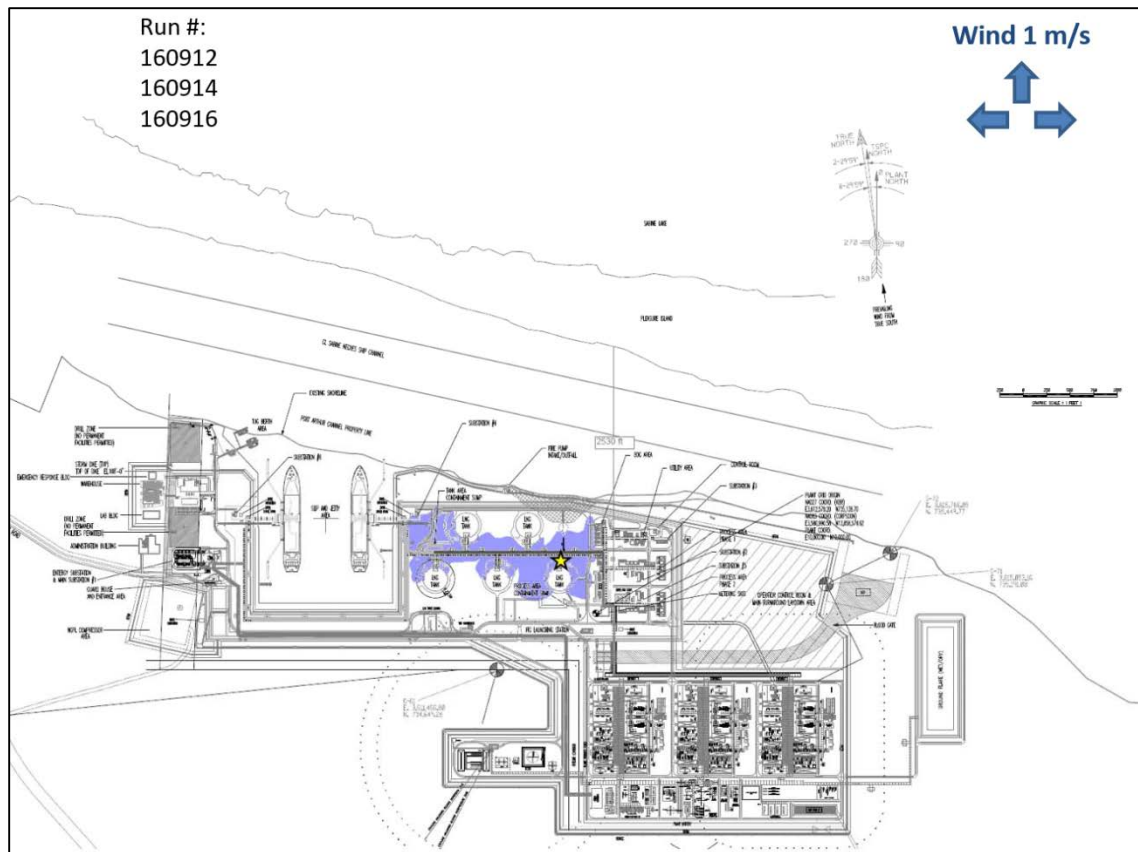
In addition to the flashing and jetting LNG design spills, the LNG facilities also resulted in the largest liquid design spills, including in locations near process areas. The governing liquid spill cases considered by Golden Pass included the full guillotine of:

- an LNG liquefaction rundown line at approximately 1,886,541 pounds per hour (lbs/hr); and
- an LNG storage tank withdrawal header at approximately 5,359,350 lbs/hr.

Golden Pass used FLACS to simulate the vapor dispersion from the LNG liquid spills into impoundments. Both the sumps and the ground-level troughs collecting LNG spills would be lined with insulated concrete. Figures 4.12.1-6 and 4.12.1-7 show that the one-half LFL dispersion results from these liquid scenarios with various wind directions and speeds would be much less significant than the dispersion from the flashing and jetting LNG cases.



**Figure 4.12.1-6** Maximum Flammable Vapor Dispersion from a Full Release from the LNG Liquefaction Rundown Line (*released at the star*)



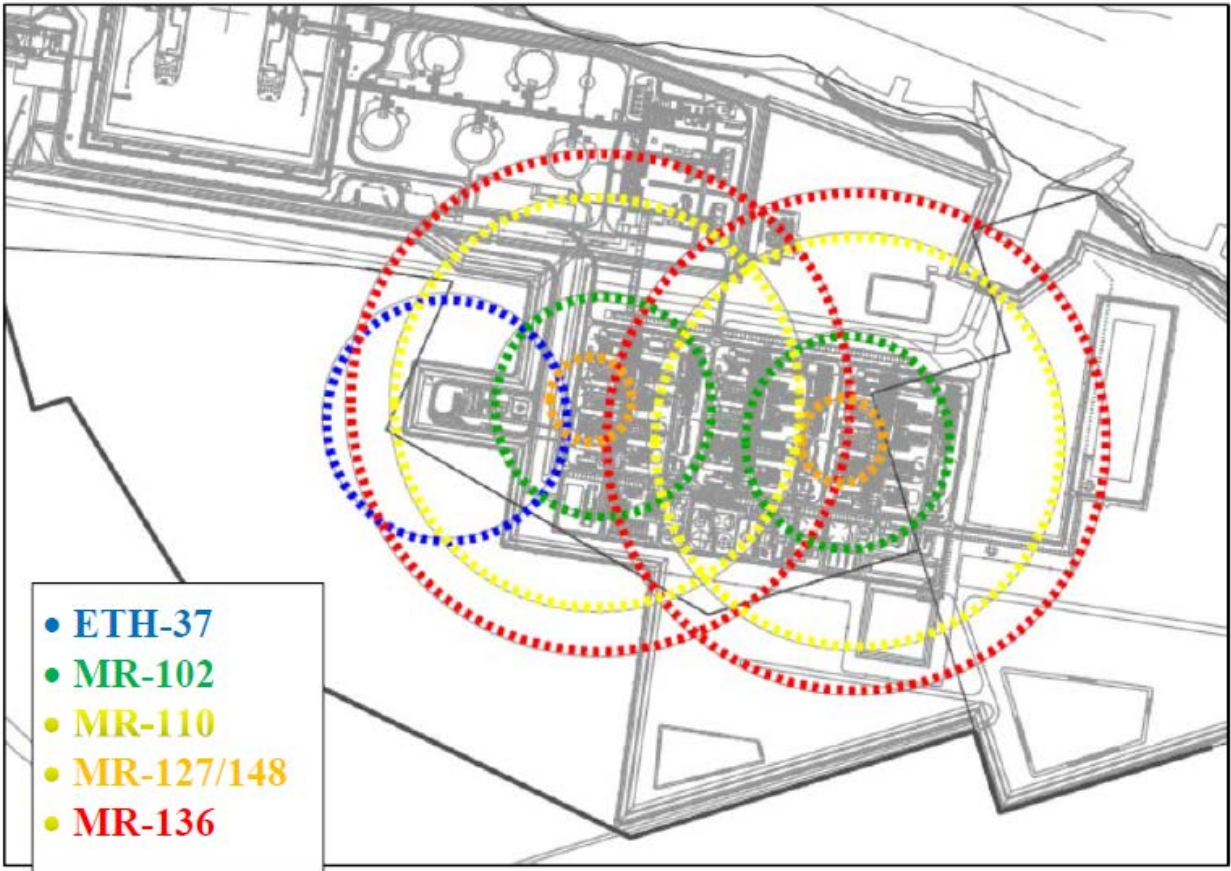
**Figure 4.12.1-7 Maximum Flammable Vapor Dispersion from a Full Release from the LNG Storage Tank Withdrawal Header Design Spill (released at the star)**

### Flammable Vapor Dispersion Design Spill Analyses for Other Process Fluids

Similar to the LNG vapor dispersion discussed in the previous subsection, Golden Pass modeled flammable vapor dispersion from design spill releases of refrigerants and condensate. The design spills determined for these fluids, as discussed under “Design Spills,” are listed in table 4.12.1-5.

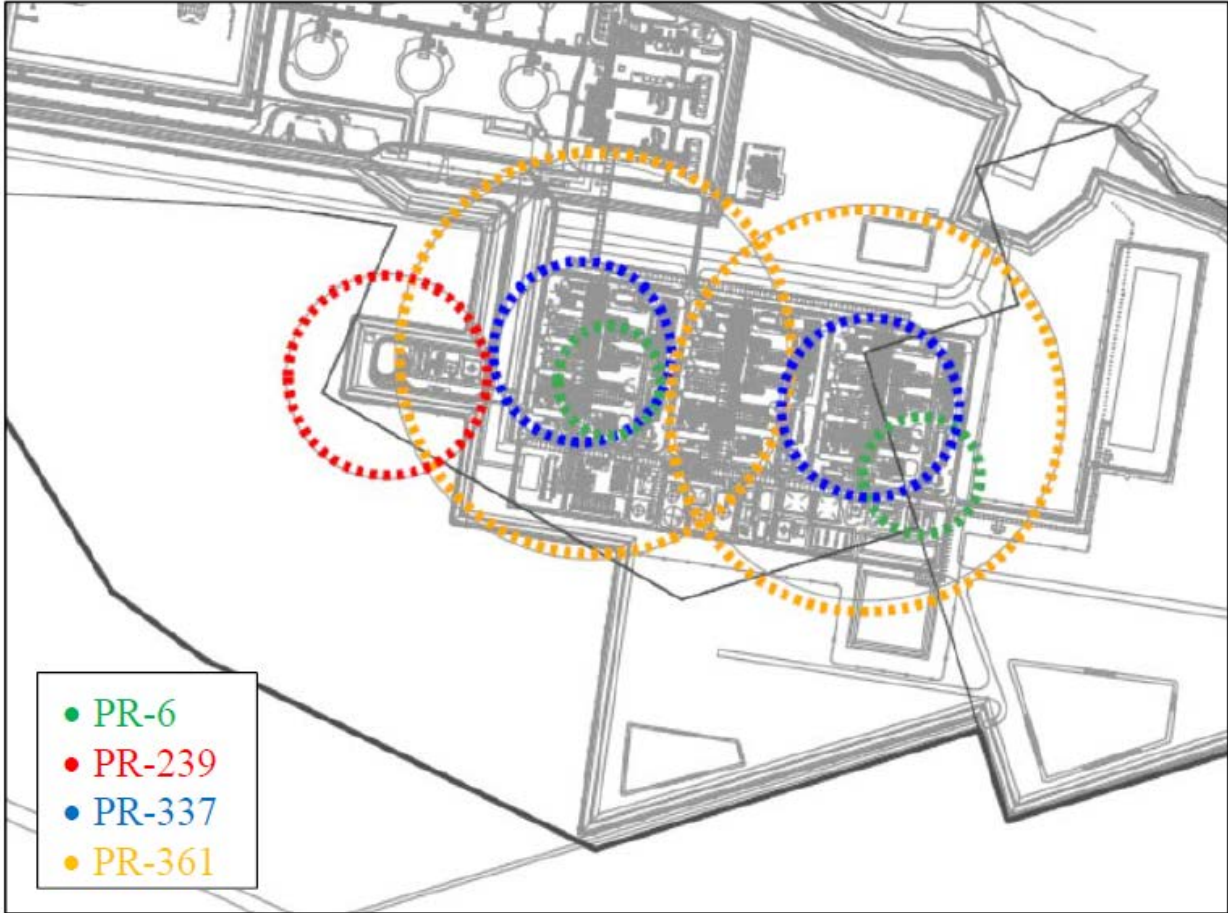
<b>TABLE 4.12.1-5</b>					
<b>Mixed Refrigerant, Ethylene, Propane, and Condensate Design Spills</b>					
<b>Scenario</b>	<b>Location</b>	<b>Hole Diameter (inches)</b>	<b>Line Size (inches)</b>	<b>Liquid Rainout (%)</b>	<b>Total Vapor Flow Rate (lb/hr)</b>
MR-102	Liquefaction area	2	30	0	630,213
MR-110	Liquefaction area	3	24	0	1,417,430
MR-127	Liquefaction area	4	24	0	2,771,870
MR-136	Liquefaction area	3	3	0	806,444
MR-148	Liquefaction area	4	4	0	2,771,870
ETH-37	Refrigerant storage area	2	2	0	295,376
PR-6	Liquefaction area	1.2	12	0	145,287
PR-239	Refrigerant storage area	2	2	0	384,996
PR-337	Liquefaction area	2	2	0	378,412
PR-361	Liquefaction area	4	4	0	1,359,900
CD-41	Liquefaction area	4	4	91	2,773
CD-55	Refrigerant storage area	4	4	92	10,925

Golden Pass used PHAST to model the flammable vapor dispersion for each of these scenarios. As shown in figures 4.12.1-8, 4.12.1-9 and 4.12.1-10, the maximum extent of the one-half LFL for these releases would remain within the facility property boundary. However, scenarios MR-127, MR-136, and MR-148 were not modeled for a 10 minute release duration. FERC staff re-modeled the scenarios for a 10 minute release duration, and the results indicated a 1 percent or less difference in dispersion distance, which would still remain within the facility property boundary.

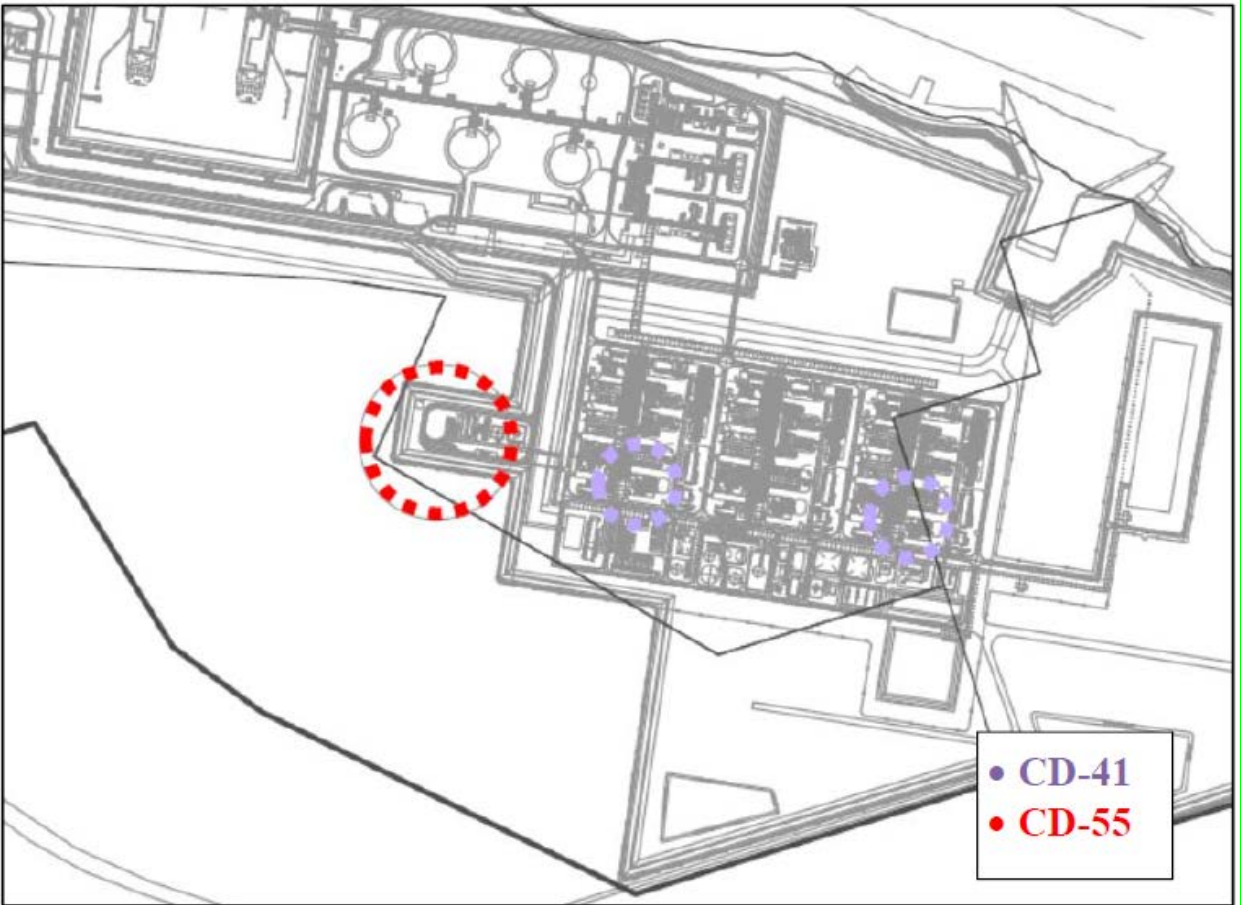


**Figure 4.12.1-8** Maximum Flammable Vapor Dispersion from Ethylene and Mixed Refrigerant Design Spills (*property line shown in bold*)





**Figure 4.12.1-9** Maximum Flammable Vapor Dispersion from Propane Design Spills (*property line shown in bold*)



**Figure 4.12.1-10 Maximum Flammable Vapor Dispersion from Hydrocarbon Condensate Design Spills (*property line shown in bold*)**

In addition, Golden Pass would take measures to mitigate flammable vapor dispersion from reaching occupied buildings. Golden Pass would install gas detection devices at the air intakes of buildings to enable isolation and deactivation of equipment. However, the proposed control room could potentially be located farther away to further reduce the risk of flammable vapors from entering the building. Therefore, **we recommend that:**

- **The final design should provide a technical review of its proposed facility design that evaluates other potential locations for the proposed control room that would increase the time available to shutdown before flammable vapors would reach the building.**

Conclusion on Flammable Vapor Dispersion

Based on the dispersion analysis presented in this section and our recommendations, we conclude that the siting of the proposed Project, with respect to flammable vapor dispersion, would not cause a significant impact on public safety or reliability. If the facility is constructed and operated, compliance with the requirements of 49 CFR 193 would be addressed as part of the DOT’s inspection and enforcement program. All vapor fences would need to be maintained to meet the regulations in 49 CFR 193.



#### 4.12.1.8 Toxic Dispersion Analysis

As discussed in section 4.1.12.2, a release of condensate, ammonia, or acid gas may form a toxic cloud. To address these hazards, 49 CFR 193.2051 requires a vapor dispersion evaluation of potential incidents in accordance with applicable sections of NFPA 59A (2001 edition). NFPA 59A, Section 2.1.1 requires that factors applicable to the specific site with a bearing on the safety of plant personnel and surrounding public be considered, including an evaluation of potential incidents and safety measures incorporated into the design or operation of the facility. Taken together, Part 193 and NFPA 59A (2001 edition) require that potential incidents (e.g., toxic releases) must be considered.

The design spills, as discussed under “Design Spills,” with toxic components are listed in table 4.12.1-6.

Scenario	Location	Hole Diameter (inches)	Line Diameter (inches)	Liquid Rainout (%)	Total Vapor Flow Rate (lb/hr)
AM-2	Liquefaction area	2	2	0	4,005
AM-33	Refrigerant storage area	0.4	vessel	90	1,018
AG-1	Liquefaction area	6.7	20	0	75,328
CD-41	Liquefaction area	4	4	91	2,773
CD-55	Refrigerant storage area	4	4	92	10,925

For the flammable vapor dispersion analysis, 49 CFR 193.2059 requires that dispersion distances be calculated for a 2.5 percent average gas concentration (one-half the LFL of LNG vapor) under meteorological conditions that result in the longest downwind distances at least 90 percent of the time. Alternatively, maximum downwind distances may be estimated for stability Class F, a wind speed of 4.5 mph, 50 percent relative humidity, and the average regional temperature. Similar uncertainty factors (e.g., one-half the AEGL of toxic materials) and similar parameters (i.e., F stability, 1–2 m/sec wind speed, 50 percent relative humidity, average regional temperature, and 0.03 m surface roughness) were used to model the dispersion from toxic fluid releases.

Table 4.12.1-7 lists the dispersion distances calculated by Golden Pass to the one-half AEGL for releases of ammonia, hydrogen sulfide, benzene, and toluene. Golden Pass stated that it considered exposure durations of 10 minutes for all releases.

TABLE 4.12.1-7

Maximum Distance to Acute Exposure Guideline Levels (in ppm) for 10-Minute Exposures

Substance	AEGL-1 (feet)	AEGL-2 (feet)	AEGL-3 (feet)
Ammonia (AM-2)	1,108	400	No hazard
Ammonia (AM-33)	414	153	59
Hydrogen sulfide (AG-1)	742	No hazard	No hazard
Benzene (CD-41)	922	270	132
Benzene (CD-55)	1,572	534	258
Toluene (CD-41)	570	188	87
Toluene (CD-55)	1,118	373	156

Golden Pass indicated that the dispersion of other toxic components in the hydrocarbon condensate, such as methyl mercaptan, were too minor to be analyzed. Golden Pass also indicated that no consideration was given to the simultaneous dispersion of benzene, toluene, xylenes, hexanes and methyl mercaptan during a condensate release, which may have cumulative effects, because no AEGL level is available for the summation of the mixture. In addition, justification was not provided for the use of 10-minute exposure times for all releases, including those with significant liquid rainout. Therefore, **we recommend that:**

- **Prior to the end of the draft EIS comment period, Golden Pass should file with the Secretary detailed technical justifications to demonstrate that exposure durations would not exceed the AEGL time used in each case.**
- **Prior to the end of the draft EIS comment period, Golden Pass should file with the Secretary technical justification to confirm that no significant cumulative toxic effects could occur due to the simultaneous dispersion of benzene, toluene, xylenes, hexanes, methyl mercaptan, and other toxic components in a hydrocarbon condensate release. Alternatively, Golden Pass should include dispersion modeling using a method that can account for the maximum extent of the potential cumulative toxic impacts from a hydrocarbon condensate release.**

All of the distances listed in table 4.12.1-7 for AEGL-2 and AEGL-3 would remain within the facility boundary. As seen in figures 4.12.1-11 through 4.12.1-14, the AEGL-1 distances would extend offsite slightly in certain areas, but any effects from these levels would not be disabling and would be transient and reversible upon cessation of the exposure. As a result, if Golden Pass adequately resolves the above technical recommendation, we would conclude that the siting of the proposed Project would not cause a significant impact on public safety with respect to the presence of the toxic components. If the facility is constructed and operated, compliance with the requirements of 49 CFR 193 would be addressed as part of the DOT's inspection and enforcement program.



**Figure 4.12.1-11** Maximum Distances to AEGL-1 for Ammonia Design Spills  
*(property line shown in bold)*

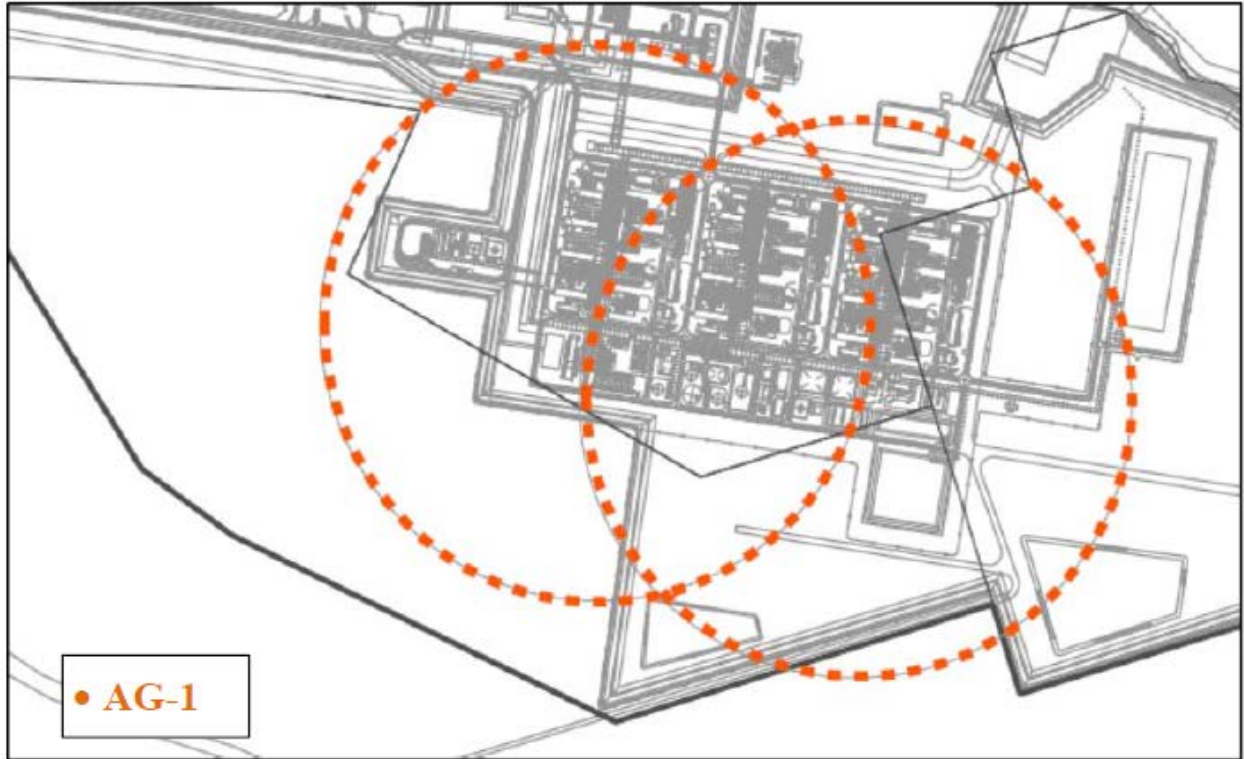
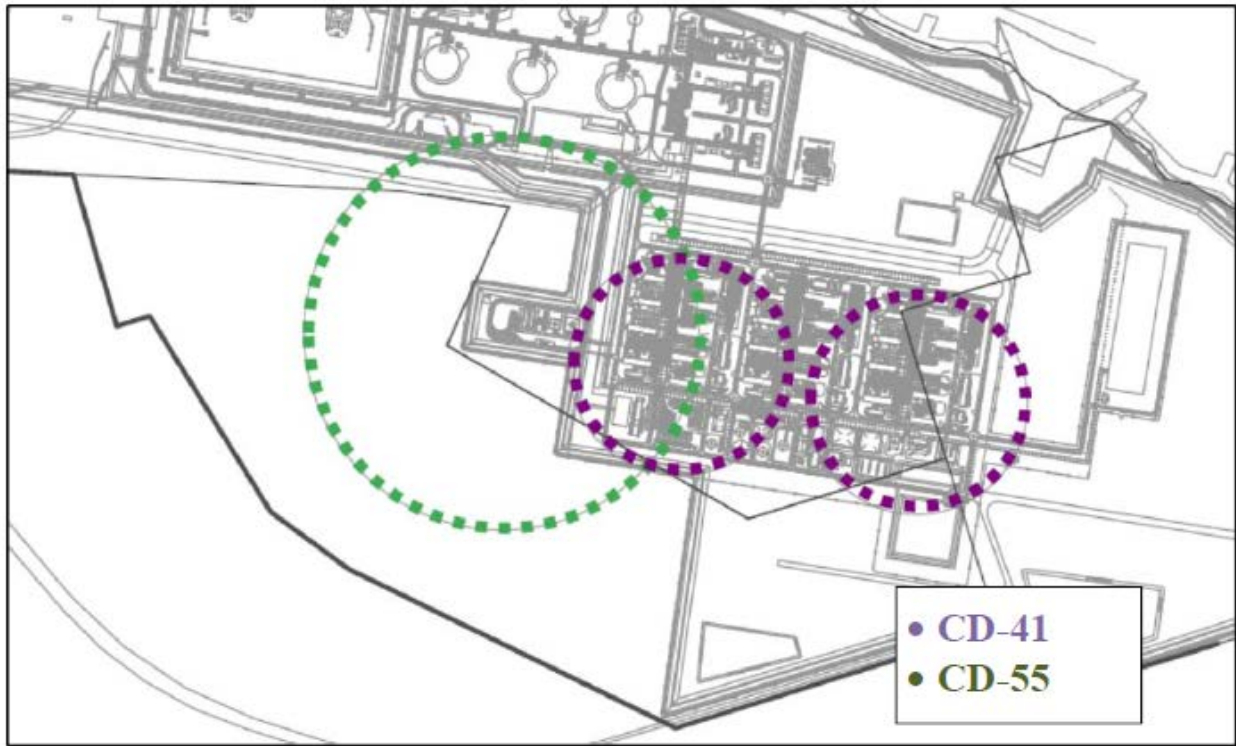
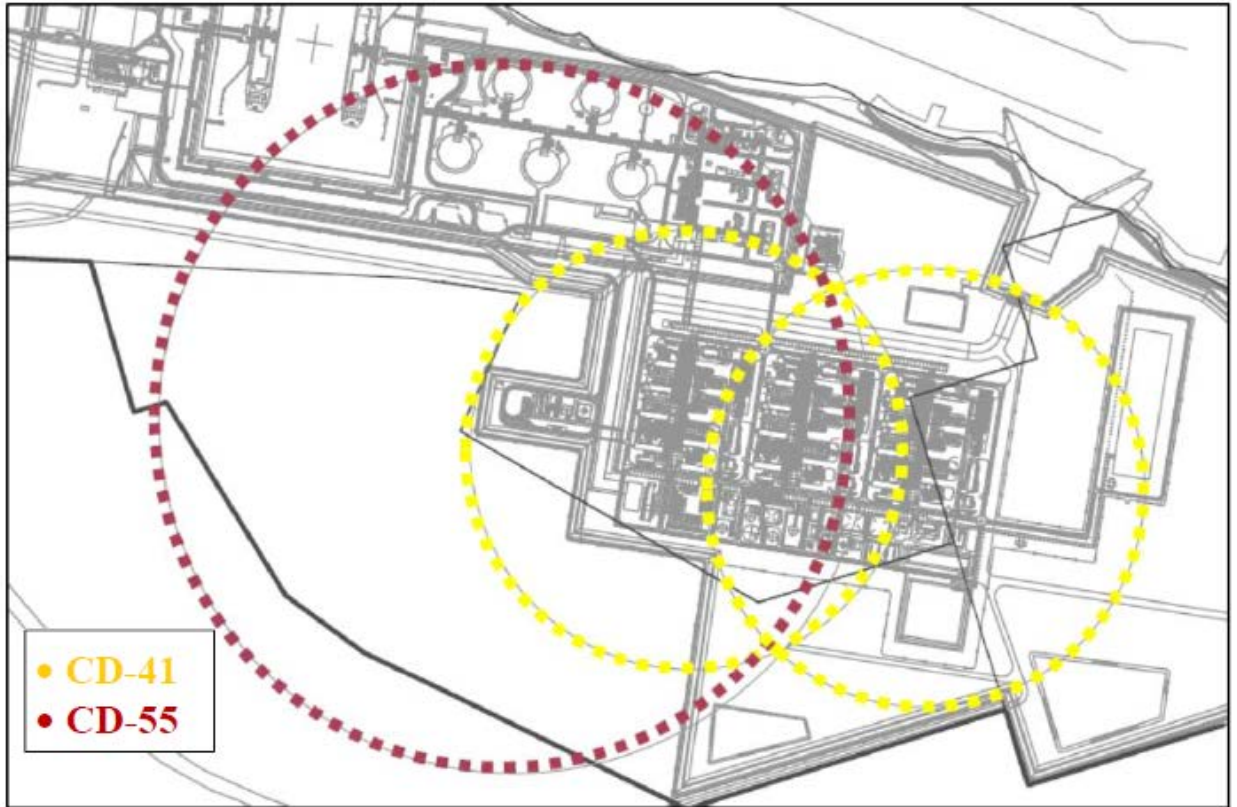


Figure 4.12.1-12 Maximum Distances to AEGL-1 for Hydrogen Sulfide in the Acid Gas Design Spill (*property line shown in bold*)



**Figure 4.12.1-13** Maximum Distances to AEGL-1 for Toluene in the Condensate Design Spills (*property line shown in bold*)



**Figure 4.12.1-14 Maximum Distances to AEGL-1 for Benzene in the Condensate Design Spills (*property line shown in bold*)**

In addition to considering toxic effects, Golden Pass would install oxygen sensors near the liquid nitrogen storage impoundment to protect operators from a localized asphyxiation hazard. The number and location of these sensors would be selected to account for the extent of the potentially oxygen-deficient atmosphere. Therefore, **we recommend that:**

- **The final design should provide vapor dispersion modeling for a release of liquid nitrogen as well as the number and location of oxygen sensors to be installed in the dispersion area.**

#### **4.12.1.9 Vapor Cloud Overpressure Analysis**

As discussed in section 4.12.1.2, the propensity of a vapor cloud to detonate or produce damaging overpressures is influenced by the reactivity of the material, the level of confinement and congestion surrounding and within the vapor cloud, and the flame travel distance. It is possible that the prevailing wind direction may cause the vapor cloud to travel into a partially confined or congested area. Section 2.1.1 of NFPA 59A (2001 edition), as adopted by 49 CFR 193, requires consideration of these factors applicable to the specific site with a bearing on the safety of plant personnel and the surrounding public.

#### **LNG Vapor Clouds**

The potential for unconfined LNG vapor cloud detonations was investigated by the Coast Guard in the late 1970s at the Naval Weapons Center in China Lake, California. Using methane, the primary component of natural gas, several experiments were conducted to determine whether unconfined LNG vapor clouds would detonate. Unconfined methane vapor clouds ignited with low-energy ignition sources

(13.5 joules) and produced flame speeds ranging from 12 to 20 mph. These flame speeds are much lower than the flame speeds associated with a deflagration with damaging overpressures or a detonation.

Additional tests were conducted to study the influence of confinement and congestion on the propensity of a vapor cloud to detonate or produce damaging overpressures. The tests used obstacles to create a partially confined and turbulent scenario but found that flame speeds developed for methane were not significantly higher than the unconfined case and were not in the range associated with detonations.

To examine the potential for detonation of an unconfined natural gas cloud containing heavier hydrocarbons that are more reactive, such as ethane and propane, the Coast Guard conducted further tests on ambient-temperature fuel mixtures of methane-ethane and methane-propane. Explosive charges were used as ignition sources for these tests. For the vapor clouds containing from 86 to 96 percent methane in near stoichiometric proportions, the Coast Guard indicated that the overpressures produced during those tests were the same overpressures produced by the ignition source alone. However, the Coast Guard found that less processed natural gas with greater amounts of heavier hydrocarbons and less methane would be more sensitive to detonation.

Although it has been possible to produce damaging overpressures and detonations of unconfined LNG vapor clouds, the Golden Pass LNG Export Project would be designed to receive feed gas with methane concentrations as low as 88.4 percent, which are not in the range shown to exhibit overpressures and flame speeds associated with high-order explosions and detonations in excess of the initiating charge. The substantial amount of initiating explosives needed to create the shock initiation during the limited range of ignitable vapor-air concentrations also renders the possibility of detonation of these vapors at an LNG plant as unrealistic.

Ignition of a confined LNG vapor cloud could result in higher overpressures. In order to prevent such an occurrence, Golden Pass would take measures to mitigate flammable vapor dispersion and ignition in confined areas, such as buildings and fired equipment. Golden Pass would install gas detection devices at the air intakes of buildings and the gas-fired turbines to enable isolation and deactivation of equipment whose continued operation could add to, or sustain, an emergency. Golden Pass indicates that other combustion equipment is located far from potential sources of natural gas, even though these intakes fall within the flammable vapor dispersion zones for both LNG and refrigerants. Therefore, to ensure that the detection and shutdown plan would be adequate, **we recommend that:**

- **The final design should provide a technical review of its proposed facility design that:**
  - a. **identifies all combustion/ventilation air intake equipment and the distances to any possible hazardous fluid release (LNG, flammable refrigerants, flammable liquids and flammable gases); and**
  - b. **demonstrates that these areas are adequately covered by hazard detection devices and indicates how these devices would isolate or shut down any combustion or ventilation equipment whose continued operation could add to or sustain an emergency.**

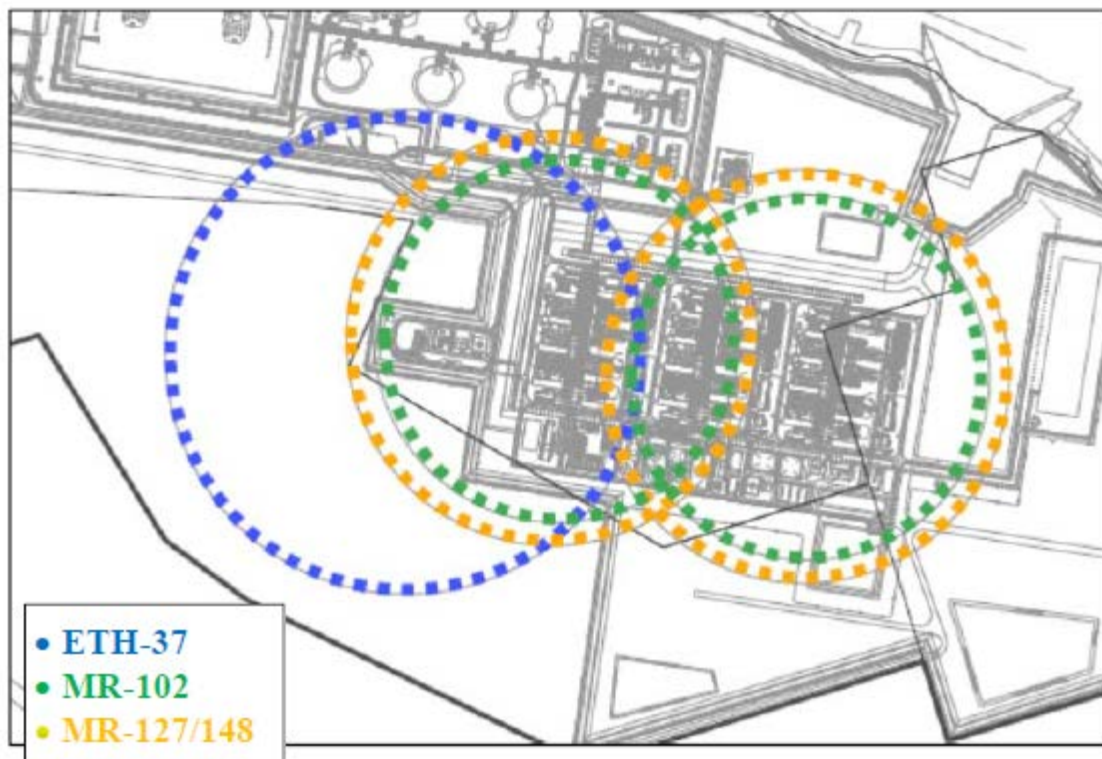
### **Vapor Clouds from Other Hazardous Fluids**

In comparison with LNG vapor clouds, there is a higher potential for unconfined propane clouds to produce damaging overpressures, and an even higher potential for unconfined ethylene vapor clouds to produce damaging overpressures. Unconfined ethylene vapor clouds also have the potential to transition to a detonation much more readily than propane. This has been shown by multiple experiments conducted by the Explosion Research Cooperative to develop predictive blast wave models for low-, medium-, and high-reactivity fuels and varying degrees of congestion and confinement (Pierorazio et al., 2005). The



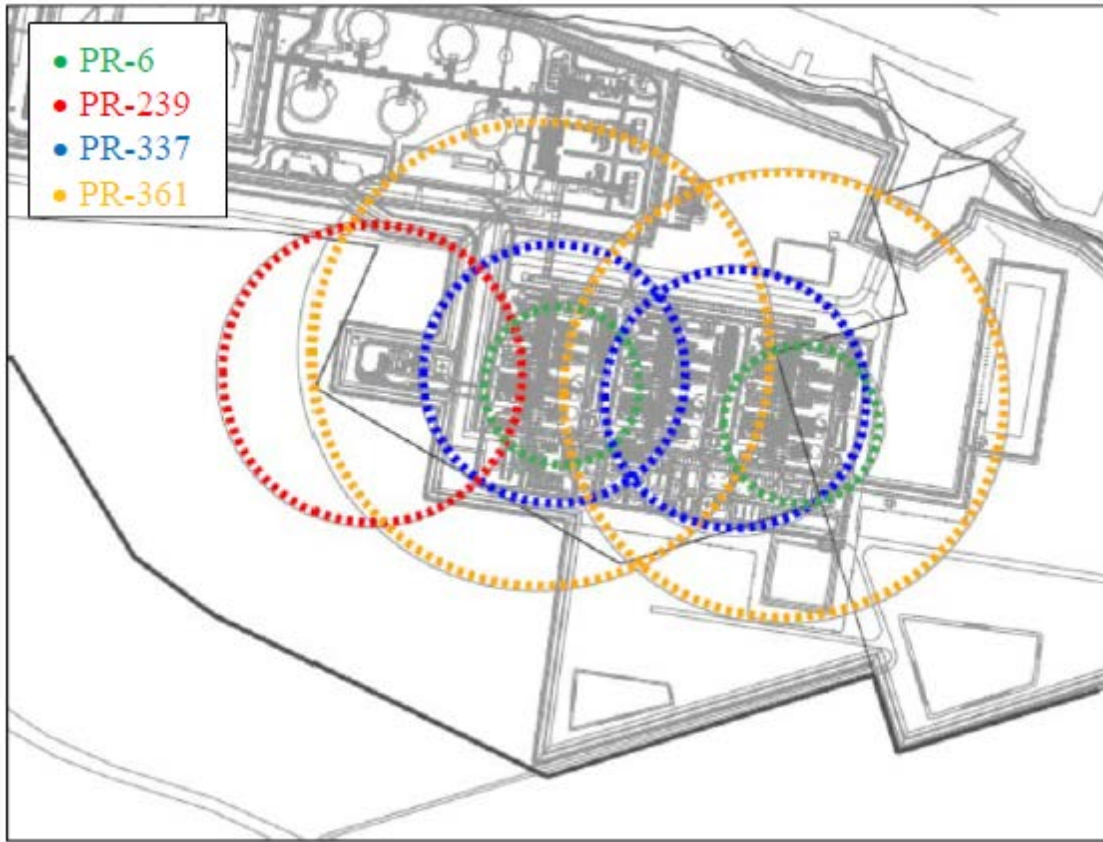
experiments used methane, propane, and ethylene, as the respective low-, medium-, and high-reactivity fuels. In addition, the tests showed that if methane, propane, or ethylene is ignited within a confined space they all have the potential to produce damaging overpressures. The mixed refrigerant (MR) and condensate process streams would contain a mixture of components such as the ones discussed above (i.e., ethylene and propane). Therefore, a potential exists for these process streams to produce unconfined vapor clouds that could produce damaging overpressures in the event of a release.

Golden Pass used the Baker-Strehlow-Tang (BST) Explosion Model in PHAST (v6.7) to estimate the distances to the 1 psi overpressure threshold resulting from the ethylene, propane, condensate, MR-127, and MR-148 design spill dispersion scenarios. The flammable vapor cloud was ignited at the maximum extent of the predicted LFL dispersion. Golden Pass indicated that a medium obstacle density was assumed, which is conservative particularly for the hose break scenarios because the truck unloading area is located in a remote area away from other congestion. For additional conservatism, the obstructed volume was assumed to include the entire vapor cloud. Figures 4.12.1-15 through 4.12.1-17 show the results of the overpressure analyses using PHAST, which demonstrate that the 1 psi overpressure threshold would not extend beyond a plant property line.



**Figure 4.12.1-15** Maximum Extent of 1 psi from Ethylene and Two Mixed Refrigerant Overpressure Scenarios (*property line shown in bold*)



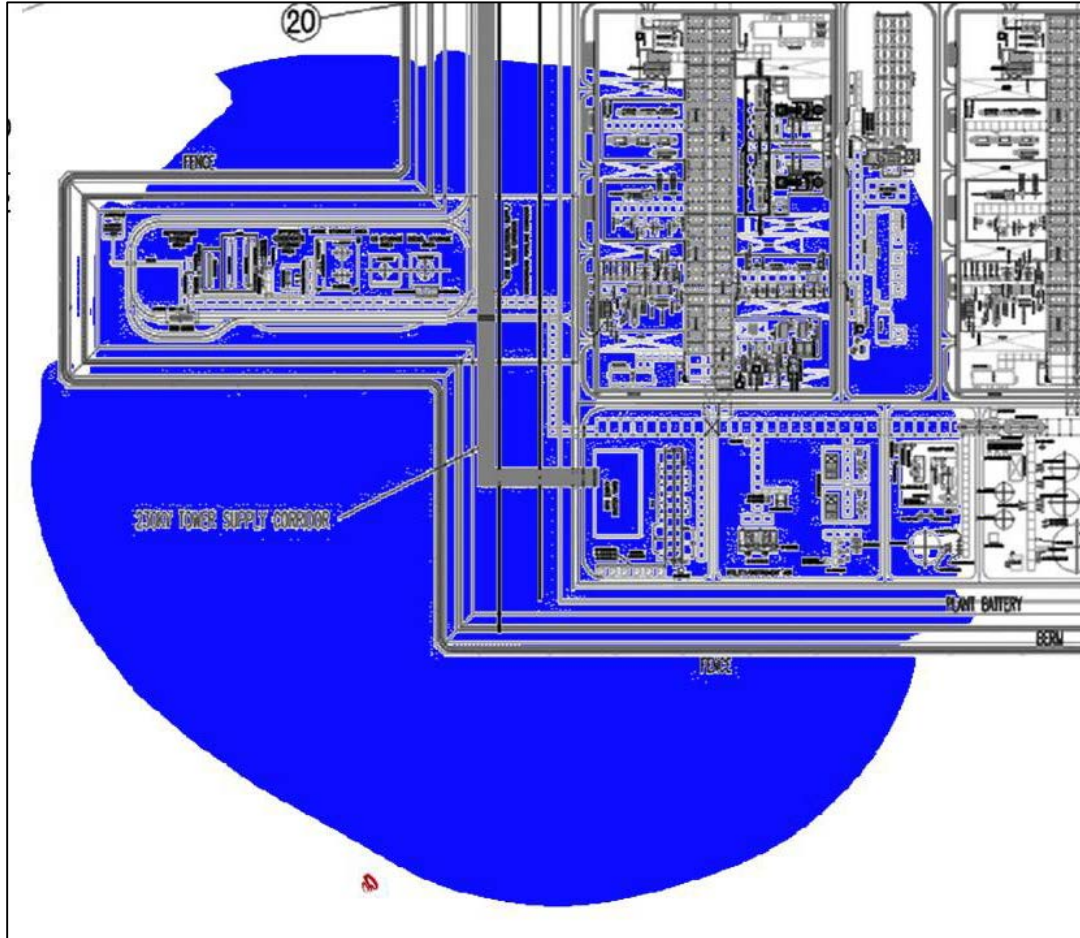


**Figure 4.12.1-16** Maximum Extent of 1 psi from Propane Overpressure Scenarios  
*(property line shown in bold)*

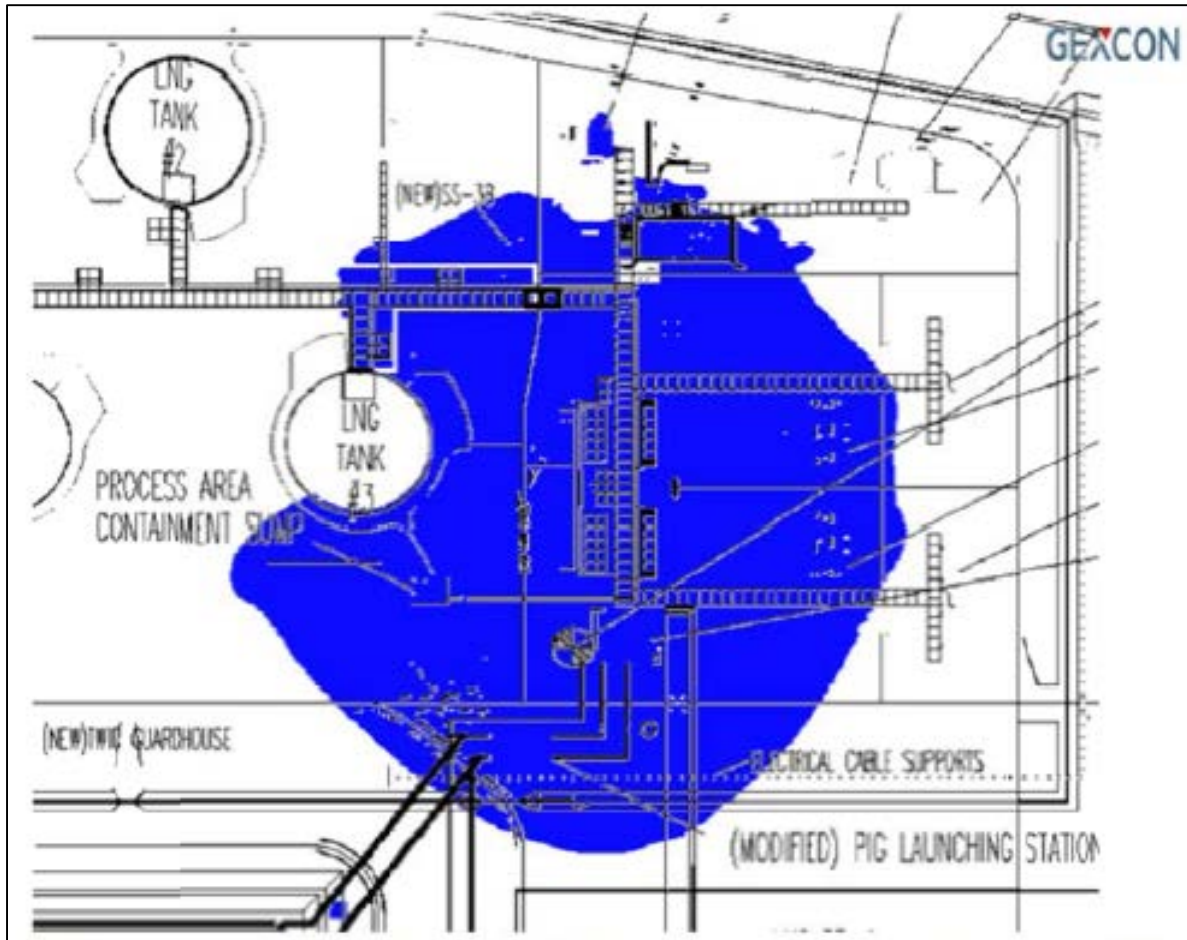


**Figure 4.12.1-17 Maximum Extent of 1 psi from Condensate Overpressure Scenarios**  
*(property line shown in bold)*

Golden Pass used FLACS to model overpressures from mixed refrigerant scenarios MR-110 and MR-136. These mixed refrigerant vapor dispersion scenarios were evaluated to determine the most significant amount of flammable vapor that would occur in a congested area. An equivalent stoichiometric cloud was determined using a Q9 mapping method, which converts realistic inhomogeneous vapor clouds from the dispersion simulations into ideal homogeneous stoichiometric clouds by taking into account that both the reactivity of a mixture and its gas expansion ratio are functions of the local stoichiometry. Ignition of the equivalent stoichiometric volume was modeled in FLACS to demonstrate the potential overpressure from that congested area. Various congested areas and ignition locations were evaluated. To account for the uncertainty in the FLACS model, the distance to 1 psi overpressure was modeled using one-half psi overpressure (an uncertainty factor of 2). Figures 4.12.1-18 through 4.12.1-20 show the results of the FLACS overpressure analyses (with an uncertainty factor of 2), which demonstrate that the 1 psi overpressure threshold would not extend beyond a plant property line.

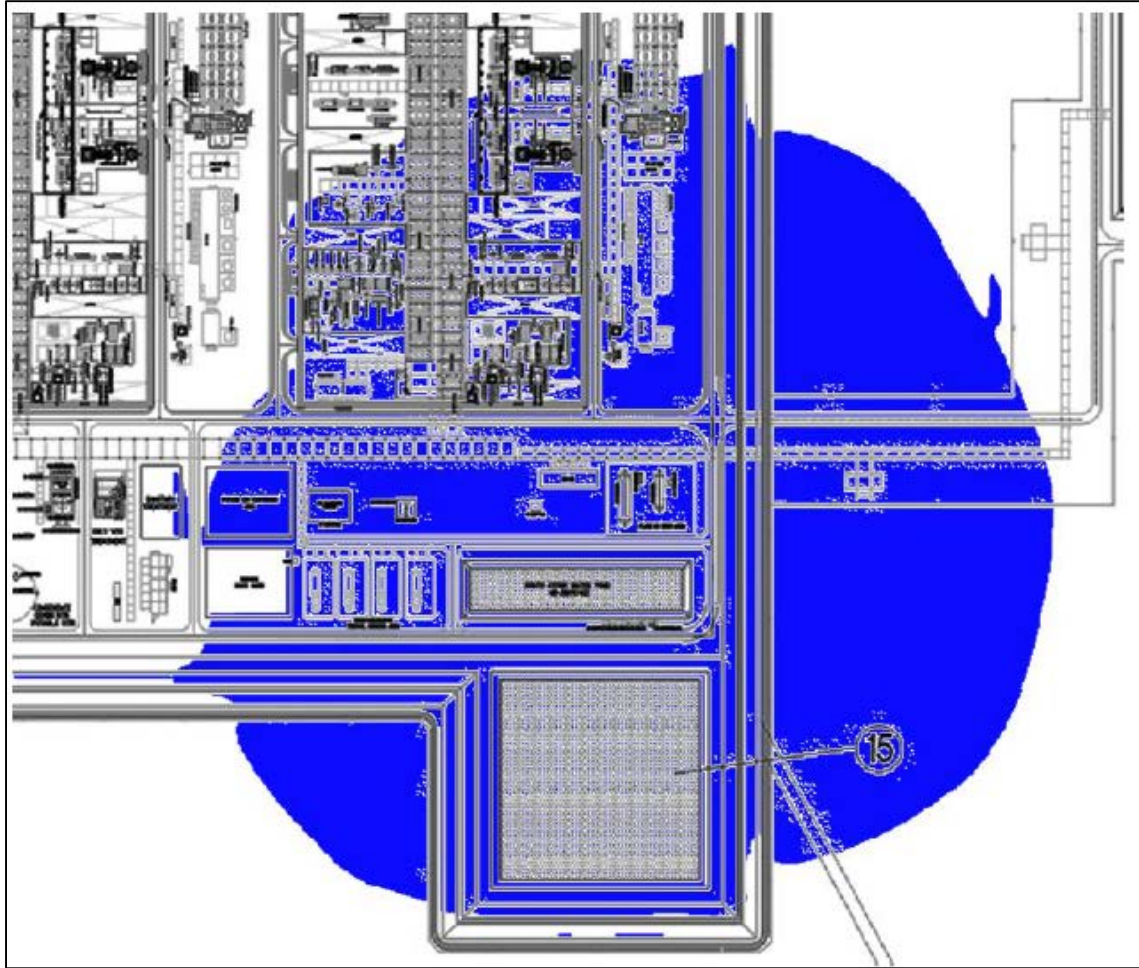


**Figure 4.12.1-18** Maximum Extent of 1 psi from Condensate Overpressure Scenarios at the Southwest Corner of the Liquefaction Area (*using an uncertainty factor of 2*) (*property line shown as a bold line in figure 4.12.1-17*)



**Figure 4.12.1-19** Maximum Extent of 1 psi from Mixed Refrigerant Scenario MR-136 from the Congested Area of Train 1 nearest to the LNG Storage Tanks (using an uncertainty factor of 2) (property line shown as a bold line in figure 4.12.1-17)





**Figure 4.12.1-20** Maximum Extent of 1 psi from Mixed Refrigerant Scenario MR-136 in the Congested Area Nearest to the Property Line (*considering an uncertainty factor of 2*) (*property line shown as a bold line in figure 4.12.1-17*)

Due to the scenario in figure 4.12.1-19, a peak reflected overpressure of 2.6 psi would be experienced at a full-containment LNG tank, but this would not be expected to be significant. However, figure 4.12.1-16 indicates that overpressures due to scenario PR-361 could also impact an existing LNG storage tank and the proposed control room building. Further, scenario PR-361 appears to have been inadvertently modeled using an inappropriate TNT method in PHAST, rather than the BST method stated. Using the BST method may increase the maximum distance to 1 psi in this case by approximately 520 feet. Scenario MR-136 may also have the ability to produce overpressures at the proposed control room. Therefore, **we recommend that:**

- **Prior to the end of the draft EIS comment period, Golden Pass should file with the Secretary an analysis demonstrating that the existing LNG storage tank and the proposed new control room building are adequately designed to withstand the overpressures predicted by design spill overpressure modeling for scenario PR-361 as well as potential overpressures from scenario MR-136 in nearby congested areas. The filing should include the results of overpressure modeling for scenario PR-361 using an appropriate**

**model. Overpressures calculated by FLACS should include an assessment of the uncertainty in the results.**

Because using the BST method appears to extend the maximum distance to 1 psi overpressures in scenario PR-361 by approximately 520 feet, this distance could extend offsite. This analysis did not account for all facility geometry, including fencing that may provide some amount of mitigation. Therefore, we recommend that:

- **Prior to the end of the draft EIS comment period, Golden Pass should file with the Secretary a revised overpressure analysis for scenario PR-361 that accounts for the geometry that would provide mitigation for the maximum distance to the 1 psi overpressure threshold.**

Based on the analysis presented in this section and upon satisfactory resolution of the above recommendations, we would conclude that the siting of the proposed facility, with respect to vapor cloud overpressures, would not cause a significant impact on public safety.

The overpressure analyses were based on the preliminary information contained in the FEED submitted by Golden Pass. Piping and equipment arrangements may differ in final design, potentially resulting in increased congestion or confinement in the liquefaction area and an increase in the overpressure distance. Therefore, we recommend that:

- **The final design should provide plant geometry models or drawings that verify the confinement and congestion represented in the FEED or provide revised overpressure calculations indicating that a 1 psi overpressure would not impact the public.**

#### **4.12.1.10 Thermal Radiation Analysis**

As discussed in section 4.12.1.2, if flammable vapors are ignited, the deflagration could propagate back to the spill source and result in a pool or jet fire causing high levels of thermal radiation (i.e., heat from a fire). In order to address this, 49 CFR 193.2057 requires each LNG container and LNG transfer system to have a thermal exclusion zone in accordance with Section 2.2.3.2 of NFPA 59A (2001 edition). NFPA 59A (2001 edition) specifies that, for design spills, the 1,600 Btu/ft<sup>2</sup>-hr flux level cannot extend beyond the facility's property line that can be built upon. The 1,600 Btu/ft<sup>2</sup>-hr flux level is associated with producing second degree burns in approximately 30 seconds, assuming no shielding from the fire. At distances farther away from the fire, the flux levels would be lower.

Part 193 requires the use of the LNGFIRE3 computer program model developed by the Gas Research Institute to determine the extent of the thermal radiation distances. Part 193 stipulates that the wind speed, ambient temperature, and relative humidity that produce the maximum exclusion distances must be used, except for conditions that occur less than 5 percent of the time based on recorded data for the area. Golden Pass selected the following ambient conditions to produce the maximum exclusion distances: wind speeds from 0 to 18.7 mph, an ambient temperature of 42°F, and a 45-percent relative humidity. We agree with Golden Pass' selection of ambient conditions, which were also used in the thermal radiation siting analysis for the original Golden Pass LNG terminal facilities.

For its analysis, Golden Pass used LNGFIRE3 to calculate thermal radiation distances for 1,600, 3,000, and 10,000 Btu/ft<sup>2</sup>-hr incident radiant heat levels for the sumps that could contain flammable liquids. Although LNGFIRE3 is specifically designed to calculate thermal radiation flux levels for LNG pool fires, LNGFIRE3 can also be used to conservatively calculate the thermal radiation flux levels for flammable hydrocarbons such as ethylene and propane. Two of the parameters used by LNGFIRE3 to calculate the thermal radiation flux are the mass burning rate of the fuel and the surface emissive power (SEP) of the

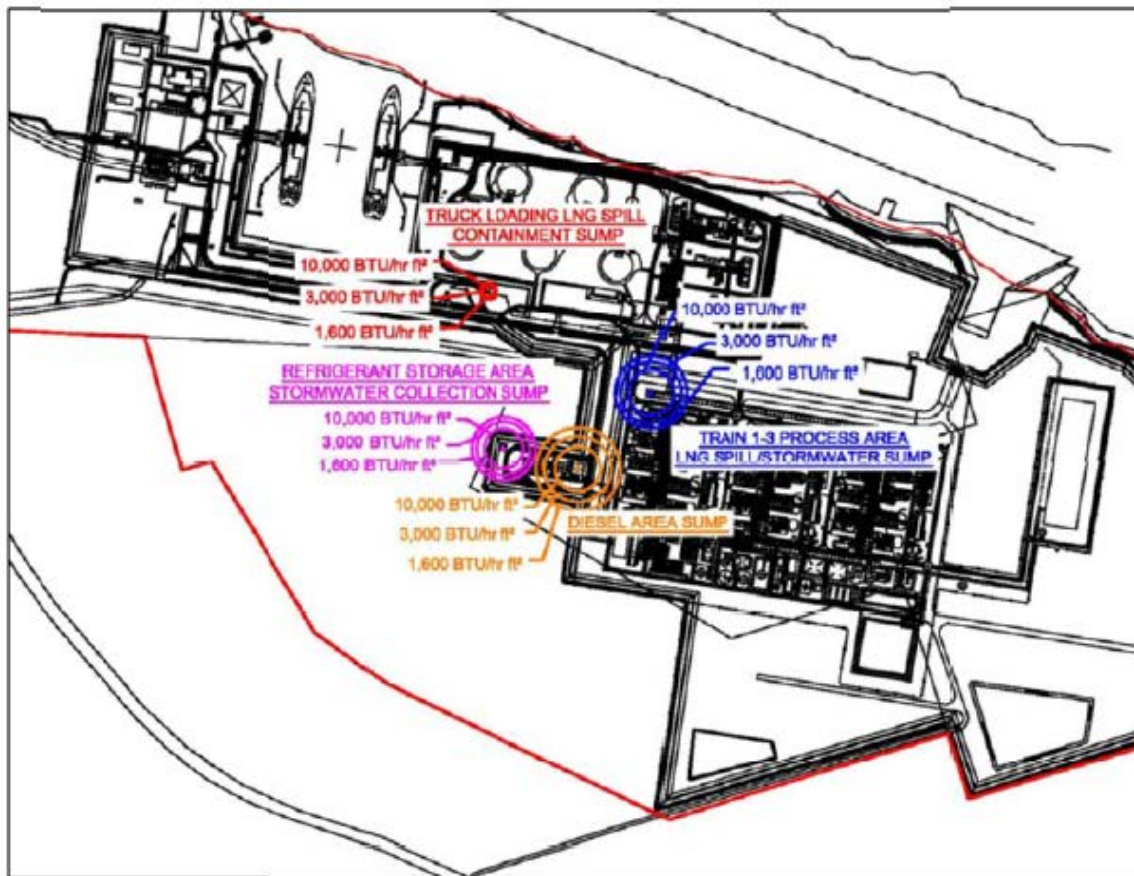
flame, which is an average value of the thermal radiation flux emitted by the fire. The mass burning rate and SEP of an ethylene or propane fire would be lower than an equally sized LNG fire. Because the thermal radiation from a pool fire depends on the mass burning rate and SEP, the thermal radiation distances required for ethylene and propane fires would not extend as far as distances calculated for an LNG fire in the same sump.

The resulting maximum thermal radiation distances are shown in table 4.12.1-8 and figure 4.12.1-21. The 1,600 Btu/ft<sup>2</sup>-hr incident radiant heat levels from all of the sumps would remain within the facility property lines.

<b>TABLE 4.12.1-8</b>			
<b>Thermal Radiation Zones for Impoundment Basins</b>			
	<b>Thermal Flux Level (Btu/ft<sup>2</sup>-hr)</b>		
	<b>10,000</b>	<b>3,000</b>	<b>1,600</b>
Distance from process area sump (ft)	187	252	298
Distance from truck loading sump (ft)	50	65	73
Distance from refrigerant storage sump (ft)	174	234	277
Distance from diesel area storage sump (ft)	195	286	359

FERC staff calculated a 5 percent longer distance to 1,600 Btu/ft<sup>2</sup>/hr from the diesel area sump, which would still remain well within the plant property line. Although Golden Pass provided thermal radiation modeling for the four sumps described in table 4.12.1-8, it is not clear why Golden Pass did not provide thermal radiation calculations for other Project sumps. Therefore, **we recommend that:**

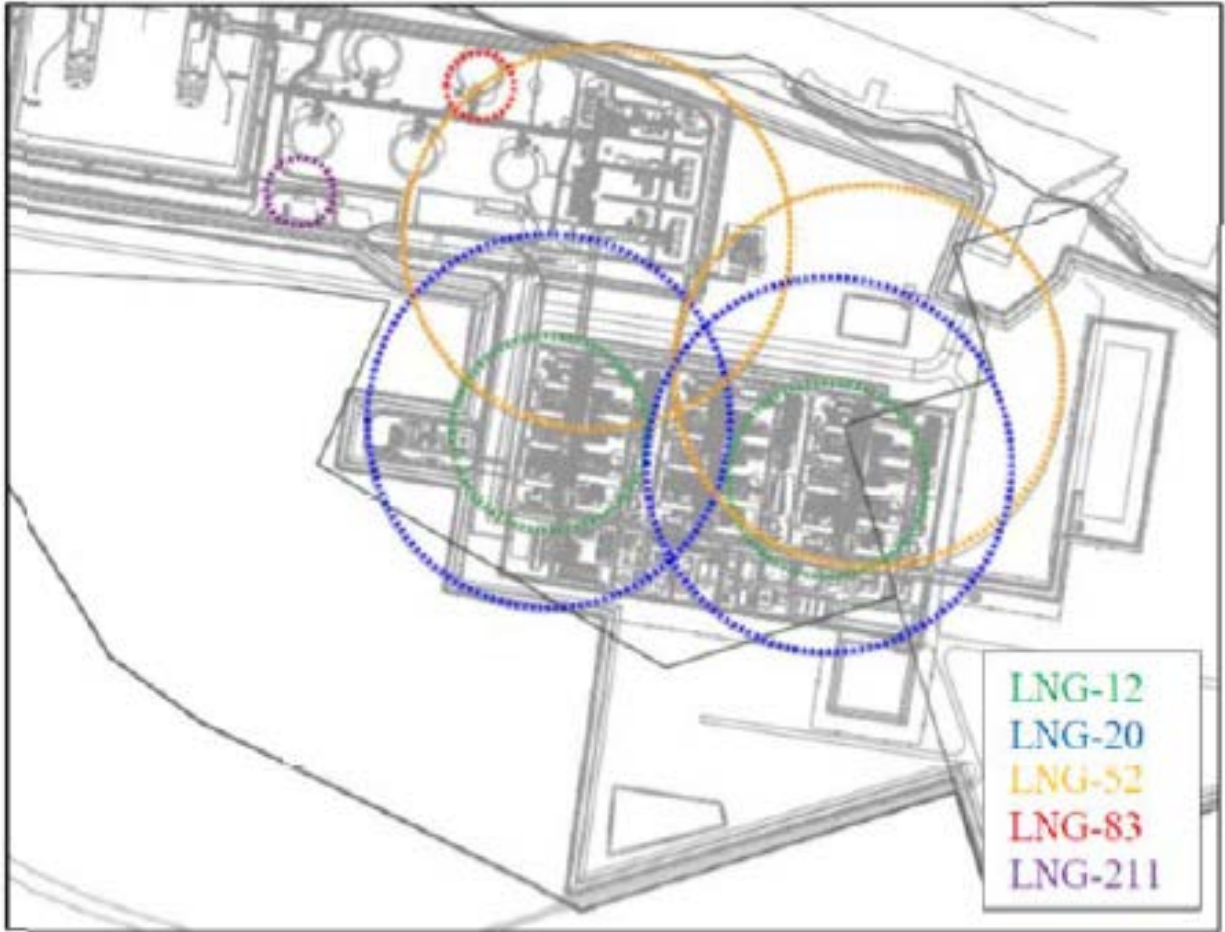
- **Prior to the end of the draft EIS comment period, Golden Pass should file with the Secretary thermal radiation calculations for all impoundment sumps other than the ones listed in table 4.12.1-8 that could contain flammable fluids, such as sumps for oil, the thermal oxidizer/flare area, or the compressor turbine drives, as listed in the drawings filed in Response 9 in the September 25, 2015 filing.**



**Figure 4.12.1-21 Maximum Distance to Thermal Radiation Levels from Impoundment Sumps**

Golden Pass also used PHAST to evaluate the thermal radiation from jet fires for all flammable design spills from their release locations. Out of all the flammable design spills, the LNG design spills produced the greatest distances to 1,600 Btu/ft<sup>2</sup>-hr, and these zones remained onsite, as shown in figure 4.12.1-22.





**Figure 4.12.1-22 Maximum Distance to 1,600 Btu/ft<sup>2</sup>-hr from Jet Fires from the LNG Design Spills (*property line shown in bold*)**

Fires may also cause failures of nearby storage vessels, piping, and equipment. The failure of a pressurized vessel could cause fragments of material to fly through the air at high velocities, posing damage to surrounding structures and a hazard for operating staff, emergency personnel, or other individuals in proximity to the event. In addition, failure of a pressurized vessel when the liquid is at a temperature significantly above its normal boiling point could result in a BLEVE. BLEVEs can produce overpressures when the superheated liquid rapidly changes from a liquid to a vapor upon the release from the vessel. BLEVEs of flammable liquids can produce a subsequent fireball if they are ignited upon their release. To mitigate the potential for BLEVEs and other failures, Golden Pass indicated that the proposed design includes numerous measures, including hazard detection equipment, emergency shutdowns that would isolate inventory and decrease pressure, firewater to cover areas where jet fires could impinge, dry chemical systems to suppress fires, and emergency planning and firefighting training. The layers of protection proposed by Golden Pass did not appear to include passive measures. Therefore, **we recommend that:**

- **Prior to initial site preparation, Golden Pass should file additional layers of protection in the form of passive mitigation to mitigate the potential for an initiating event to develop into a BLEVE incident.**

Based on the thermal radiation analysis presented in this section and upon satisfactory resolution of our recommendation to address thermal radiation from all applicable sumps, we would conclude that the

siting of the proposed Project, with respect to thermal radiation, would not cause a significant impact on public safety.

#### **4.12.1.11 LNG Marine Carriers**

In accordance with 33 CFR 127, the Coast Guard previously provided a LOR regarding the suitability of the Sabine-Neches Waterway for the type and frequency of LNG carrier traffic associated with the Golden Pass LNG terminal.<sup>52</sup> This LOR was considered by the Commission during the original siting review for the Golden Pass LNG terminal, which commenced service in 2011 as an LNG import facility. On September 27, 2012, Golden Pass received authorization from the DOE to export LNG by vessel to any nation with which the United States currently has, or in the future may enter into, a Free Trade Agreement (FTA). On October 26, 2012, Golden Pass submitted an additional application to the DOE requesting authorization to export domestically produced LNG to any country with which the United States does not have an FTA. This non-FTA application is still under review by the DOE. Golden Pass has not identified specific LNG export destinations for the proposed Project.

In spring 2013, Golden Pass notified and met with the Coast Guard regarding its intent to add liquefaction facilities and begin export operations. Golden Pass indicated that the LNG vessel traffic associated with the terminal during export operations would remain at approximately 200 per year, which is the same level outlined in its previous WSA for the existing terminal. In a letter dated May 13, 2013, the Captain of the Port (COTP) stated that, as this Project would not result in an increase in the size and/or frequency of marine traffic in the Sabine-Neches waterway, neither a revised WSA nor a Letter of Intent are needed for this Project.

However, the COTP specified that applicable amendments would need to be made to the current Operations Manual, Emergency Manual, and Facility Security Plan to capture changes to operations associated with the proposed Project.

#### **4.12.1.12 Emergency Response**

Section 3A(e) of the NGA, added by Section 311 of the EPAct 2005, stipulated that in any order authorizing an LNG terminal, the Commission shall require the LNG terminal operator to develop an ERP in consultation with the Coast Guard and state and local agencies. The existing Golden Pass terminal currently has an ERP. The existing ERP would need to be updated to include the proposed Golden Pass LNG Export Project facilities and emergencies related to handling the hazardous Project fluids. Therefore, **we recommend that:**

- **Prior to initial site preparation, Golden Pass should file an updated ERP to include the Golden Pass LNG Export Project facilities as well as instructions to handle onsite emergencies related to the hazardous Project fluids.**
- **Prior to initial site preparation, Golden Pass should file an updated Cost-Sharing Plan identifying the mechanisms for funding all Project-specific security/emergency management costs that would be imposed on state and local agencies. This comprehensive plan should include funding mechanisms for the capital costs associated with any necessary security/emergency management equipment and personnel base.**

---

<sup>52</sup> Letter of Recommendation dated April 10, 2009, from Captain Plunkett, Captain U.S. Coast Guard, to Tom Burger, Vice President of Golden Pass LNG Terminal Management LLC. Filed in Docket No. CP04-386 on April 10, 2009. Accession Number 20090410-4003.

#### **4.12.1.13 Conclusions on Facility Reliability and Safety**

As part of the NEPA review, Commission staff must assess whether the proposed facilities would be able to operate safely and securely. As a result of our technical review of the preliminary engineering design, we have made a number of recommendations to be implemented prior to initial site preparation, prior to construction of final design, prior to commissioning, prior to introduction of hazardous fluids, prior to commencement of service, and throughout the life of the facility to enhance the reliability and safety of the facility and to mitigate the risk of impact on the public. Based on our analysis and recommended mitigation, we believe that the Golden Pass LNG Export Project design would include acceptable layers of protection or safeguards that would reduce the risk of a potentially hazardous scenario from developing into an event that could impact the offsite public.

In addition, we analyzed whether Golden Pass would be sited consistently with federal regulations promulgated by the DOT in 49 CFR 193. As a cooperating agency, the DOT assisted the FERC staff in evaluating whether Golden Pass' proposed design would meet the DOT siting requirements. The DOT reviewed the data and methodology Golden Pass used to determine the design spills from various leakage sources, including piping, containers, and equipment containing hazardous liquids. Golden Pass used those design spills to model hazardous releases. On June 11, 2015, the DOT provided a letter to the FERC staff stating that the DOT had no objection to Golden Pass' methodology for determining the single accidental leakage sources for candidate design spills to be used in establishing the Part 193 siting requirements for the proposed LNG liquefaction facilities. Based on the hazardous area calculations we reviewed and upon satisfactory resolution of our recommendations, we would conclude that potential hazards from the siting of the facility at this location would not cause a significant impact on public safety. The areas impacted by these design spills also appear to meet the DOT's exclusion zone requirements by either being within the facility property boundary or over a navigable body of water. If the facility is constructed and becomes operational, the facility would be subject to the DOT's inspection and enforcement program. Final determination of whether a facility is in compliance with the requirements of 49 CFR 193 would be made by the DOT staff.

#### **4.12.2 Pipeline Expansion**

##### **4.12.2.1 Pipeline Safety Standards**

Transportation of natural gas by pipeline involves some risk to the public in the event of an accident and subsequent release of gas. The greatest hazard is a fire or explosion following a major pipeline rupture.

Methane, the primary component of natural gas, is colorless, odorless, and tasteless. It is not toxic but is classified as a simple asphyxiate, possessing a slight inhalation hazard. If breathed in high concentration, oxygen deficiency can result in serious injury or death.

Methane has an ignition temperature of 1,000 °F and is flammable at concentrations between 5 and 15 percent in air. Unconfined mixtures of methane in air are not explosive. However, a flammable concentration within an enclosed space in the presence of an ignition source can explode. It is buoyant at atmospheric temperatures and disperses rapidly in air.

The DOT is mandated to provide pipeline safety under 49 USC 601. The DOT PHMSA Office of Pipeline Safety (OPS) administers the national regulatory program to ensure the safe transportation of natural gas and other hazardous materials by pipeline. It develops safety regulations and other approaches to risk management that ensure safety in the design, construction, testing, operation, maintenance, and emergency response of pipeline facilities. Many of the regulations are written as performance standards that set the level of safety to be attained and allow the pipeline operator to use various technologies to achieve safety. The PHMSA ensures that people and the environment are protected from the risk of pipeline

incidents. This work is shared with state agency partners and others at the federal, state, and local level. Section 5(a) of the Natural Gas Pipeline Safety Act provides for a state agency to assume all aspects of the safety program for intrastate facilities by adopting and enforcing the federal standards, while Section 5(b) permits a state agency that does not qualify under Section 5(a) to perform certain inspection and monitoring functions. The States of Louisiana and Texas have Section 5(a) certifications.

The DOT pipeline standards are published in 49 CFR 190 to 199. Part 192 addresses natural gas pipeline safety issues. Under a Memorandum of Understanding on Natural Gas Transportation Facilities (Memorandum) dated January 15, 1993, between the DOT and the FERC, the DOT has the exclusive authority to promulgate federal safety standards used in the transportation of natural gas. Section 157.14(a)(9)(vi) of the FERC's regulations require an applicant to certify that the applicant will design, install, inspect, test, construct, operate, replace, and maintain the facility for which a certificate is requested in accordance with federal safety standards and plans for maintenance and inspection, or to certify that the applicant has been granted a waiver of the requirements of the safety standards by the DOT in accordance with Section 3(e) of the Natural Gas Pipeline Safety Act. Golden Pass has stated that it would design, construct, operate, and maintain its pipeline and aboveground facilities associated with the Pipeline Expansion in accordance with the DOT's Minimum Federal Safety Standards in 49 CFR 192.

The FERC accepts this certification and does not impose additional safety standards other than the DOT standards. If the Commission becomes aware of an existing or potential safety problem, there is a provision in the Memorandum to promptly alert the DOT. The Memorandum also provides for referring complaints and inquiries made by state and local governments and the general public involving safety matters related to pipelines under the Commission's jurisdiction. The FERC also participates as a member of the DOT's Technical Pipeline Safety Standards Committee, which determines whether proposed safety regulations are reasonable, feasible, and practicable.

The regulations at 49 CFR 192 are intended to ensure adequate protection for the public and to prevent natural gas facility accidents and failures. Part 192 specifies material selection and qualification; minimum design requirements; and protection from internal, external, and atmospheric corrosion. Part 192 also defines area classifications, based on population density in the vicinity of the pipeline, and specifies more rigorous safety requirements for populated areas. The class location unit is an area that extends 220 yards on either side of the centerline of any continuous 1-mile length of pipeline. The four area classifications are defined as follows:

- Class 1 – location with 10 or fewer buildings intended for human occupancy;
- Class 2 – location with more than 10 but fewer than 46 buildings intended for human occupancy;
- Class 3 – location with 46 or more buildings intended for human occupancy, or where the pipeline lies within 100 yards of any building or small well-defined outside area occupied by 20 or more people during normal use; and
- Class 4 – location where buildings with four or more stories aboveground are prevalent.

Class locations representing more populated areas require higher safety factors in pipeline design, testing, and operation. Buried pipelines constructed on land in Class 1 locations must be provided with a minimum coverage of 30 inches in normal soil and 18 inches in consolidated rock. Class 2, 3, and 4 locations, as well as drainage ditches of public roads and railroad crossings, require a minimum cover of 36 inches in normal soil and 24 inches in consolidated rock. All pipelines installed in navigable rivers, streams, and harbors must have a minimum cover of 48 inches in normal soil or 24 inches in consolidated rock.

The entire length of the proposed Pipeline Expansion would be within a Class 1 location. Therefore, the pipeline would be constructed to meet the Class 1 standards of a minimum coverage of 30 inches in normal soil and 18 inches in consolidated rock.

Part 192.179 specifies the maximum distance from a point on a pipeline to a sectionalizing block valve: each point on a pipeline in a Class 1 location must be within 10 miles of a block valve. In Class 2 locations, the distance is 7.5 miles; in Class 3 and 4 locations, the distance is 4 and 2.5 miles respectively. Pipe wall thickness and pipeline design pressures, hydrostatic test pressures, MAOP, inspection and testing of welds, and frequency of pipeline patrols and leak surveys also must conform to higher standards in more populated areas.

If a subsequent increase in population density adjacent to the right-of-way indicates a change in class location above the existing design for the pipeline, Golden Pass would reduce the MAOP or replace the segment with pipe of sufficient grade and wall thickness, if required, to comply with the DOT code of regulations for the new class location.

In 2002, Congress passed an act to strengthen the nation's pipeline safety laws. The Pipeline Safety Improvement Act of 2002 (HR 3609) was passed by Congress on November 15, 2002, and signed into law by the President in December 2002. Since December 17, 2004, gas transmission operators are required to develop and follow a written integrity management program that contains all the elements described in 49 CFR 192.911 and addresses the risks for each covered transmission pipeline segment. Specifically, the law establishes an integrity management program that applies to all high-consequence areas (HCA). The DOT (68 FR 69778, 69 FR 18228, and 69 FR 29903) defines HCAs as they relate to the different class zones, potential impact circles, or areas containing an identified site as defined in 49 CFR 192.903.

The OPS published a series of rules from August 6, 2002, to May 26, 2004 (69 FR 29903), that defines HCAs as areas where a gas pipeline accident could do considerable harm to people and their property and requires an integrity management program to minimize the potential for an accident. This definition satisfies, in part, the Congressional mandate in 49 USC 60109 for the OPS to prescribe standards that establish criteria for identifying each gas pipeline facility in a high-density population area.

An HCA may be defined in one of two ways. In the first method, an HCA includes:

- current Class 3 and 4 locations;
- any area in Class 1 or 2 locations where the potential impact radius<sup>53</sup> is greater than 660 feet and 20 or more buildings are intended for human occupancy within the potential impact circle;<sup>54</sup> or
- any area in Class 1 or 2 locations where the potential impact circle includes an identified site.

In the second method, an HCA includes any area within a potential impact circle that contains:

- 20 or more buildings intended for human occupancy; or
- an identified site.

---

<sup>53</sup> The potential impact radius is calculated as the product of 0.69 and the square root of the MAOP of the pipeline in pounds per square inch multiplied by the pipeline diameter in inches.

<sup>54</sup> The "potential impact circle" is a circle with a radius equal to the potential impact radius.

Once a pipeline operator has determined the HCAs on its pipeline, it must apply the elements of its integrity management program to those segments of the pipeline within the HCAs. The DOT regulations specify the requirements for the integrity management plan in 49 CFR 192.911.

The entirety of the proposed route of the Pipeline Expansion is located in a Class 1 area, and no potential HCAs occur in proximity to the proposed Pipeline improvements. Therefore, the Pipeline Expansion would be designed, constructed, operated, and maintained in accordance with the DOT Minimum Federal Safety Standards in 49 CFR 192.

The minimum standards for operating and maintaining pipeline facilities are prescribed in 49 CFR 192, including the requirement to establish a written plan governing these activities. Golden Pass would patrol and inspect its pipeline on a periodic basis in accordance with the DOT requirements or better. The frequency of these inspections would be affected by activity along the pipeline route, such as construction or possible encroachment. These inspections would identify conditions indicative of pipeline leaks, evidence of pipeline damage or deterioration, damage to erosion controls, loss of cover, third party activities, or conditions that may presently or in the future affect pipeline integrity, safety, or operation of the pipeline. Golden Pass would include the Pipeline Expansion in the Texas and Louisiana “One Call” programs.

Under 49 CFR 192.615, each pipeline operator also must establish an emergency plan that includes procedures to minimize the hazards in a natural gas pipeline emergency. Golden Pass has an ERP that conforms to these requirements and would update and modify the plan to include the Pipeline Expansion. Key elements of the ERP include procedures for the following:

- receiving, identifying, and classifying emergency events, gas leakage, fires, explosions, and natural disasters;
- establishing and maintaining communications with local fire, police, and public officials, and coordinating emergency response;
- emergency shutdown of the system and safe restoration of service;
- making personnel, equipment, tools, and materials available at the scene of an emergency; and
- protecting people first and then property, and making them safe from actual or potential hazards.

Part 192 requires that each operator establish and maintain liaison with appropriate fire, police, and public officials to learn the resources and responsibilities of each organization that may respond to a natural gas pipeline emergency, and to coordinate mutual assistance. The operator also must establish a continuing education program to enable customers, the public, government officials, and those engaged in excavation activities to recognize a gas pipeline emergency and report it to appropriate public officials. Golden Pass would provide the appropriate training to local emergency service personnel before the Pipeline Expansion is placed in service. No additional specialized local fire protection equipment would be required to handle pipeline emergencies.

#### 4.12.2.2 Pipeline Accident Data

The DOT requires all operators of natural gas transmission pipelines to notify the DOT of any significant incidents and to submit a report within 20 days. “Significant incidents” are defined as any leaks that:

- cause a death or personal injury requiring hospitalization; or
- involve property damage of more than \$50,000 in 1984 dollars.<sup>55</sup>

During the 20-year period from 1994 through 2013, a total of 1,238 significant incidents were reported on the more than 300,000 total miles of natural gas transmission pipelines nationwide (PHMSA, 2014). Additional insight into the nature of service incidents may be gained by examining the primary factors that caused the failures. Table 4.12.2-1 provides a distribution of the causal factors, as well as the number of incidents by cause. The two most dominant incident causes are (1) corrosion [rust]; and (2) pipeline material, weld, or equipment failure; these two causes constitute 48.1 percent of all significant incidents. The pipelines included in the data set in table 4.12.2-1 vary widely in terms of age, pipe diameter, and level of corrosion control. Each variable influences the incident frequency that may be expected for a specific segment of pipeline. The frequency of significant incidents is strongly dependent on pipeline age. Older pipelines have a higher frequency of corrosion incidents because corrosion is a time-dependent process.

<b>TABLE 4.12.2-1</b>		
<b>Significant Incidents for Natural Gas Transmission Pipelines (1994 through 2013) <u>a</u></b>		
<b>Cause</b>	<b>Number of Incidents</b>	<b>Percent of Total Incidents <u>b</u></b>
Corrosion	293	23.6
Pipeline material, weld, or equipment failure	304	24.5
Excavation <u>c</u>	211	16.9
Natural force damage	143	11.4
Other outside forces <u>d</u>	74	5.4
Incorrect operation	34	2.7
All other causes <u>e</u>	179	14.4
<b>TOTAL</b>	<b>1,238</b>	<b>98.9</b>
<b>Notes:</b>		
<u>a</u> All data gathered from PHMSA Significant Incident Files, July 16, 2014. ( <a href="http://primis.phmsa.dot.gov/comm/reports/safety/SigPSIDet_1994_2013_US.html?nocache=8649#_ngtrans">http://primis.phmsa.dot.gov/comm/reports/safety/SigPSIDet_1994_2013_US.html?nocache=8649#_ngtrans</a> ).		
<u>b</u> Due to rounding, column does not equal 100 percent.		
<u>c</u> Includes third-party damage.		
<u>d</u> Fire, explosion, vehicle damage, previous damage, intentional damage.		
<u>e</u> Miscellaneous causes or unknown causes.		

<sup>55</sup> \$50,000 in 1984 dollars is about \$114,087 as of June 5, 2014 (Bureau of Labor Statistics 2014).

The use of both an external protective coating and a cathodic protection system (a technique to reduce corrosion of the natural gas pipeline), required on all pipelines installed after July 1971, significantly reduces the corrosion rate compared to unprotected or partially protected pipe.

Outside forces, including excavations and natural events, are the cause in 33.7 percent of significant pipeline incidents. These mostly result from encroachment of mechanical equipment such as bulldozers and backhoes; earth movements caused by soil settlement, washouts, or geologic hazards; weather effects such as winds, storms, and thermal strains; and willful damage. Table 4.12.2-2 provides the types of significant incidents caused by outside forces, including the number of incidents for each type and the percent of total outside forces incidents it represents.

<b>TABLE 4.12.2-2</b>		
<b>Significant Incidents for Natural Gas Transmission Pipelines by Outside Forces (1994 through 2013) <u>a</u></b>		
<b>Cause</b>	<b>Number of Incidents</b>	<b>Percent of Total Incidents <u>b</u></b>
Third-party excavation damage	176	41.1
Operator excavation damage	25	5.8
Unspecified equipment damage/previous damage	10	2.3
Heavy rain/floods	72	16.8
Earth movement	35	8.2
Lightning/temperature/high winds	21	4.9
Other/unspecified natural force	15	3.5
Vehicle (not engaged with excavation)	45	10.5
Fire/explosion	8	1.9
Previous mechanical damage	6	1.4
Fishing or maritime activity	7	1.6
Intentional damage	1	0.2
Other/unspecified outside force	7	1.6
<b>TOTAL</b>	<b>428</b>	<b>99.8</b>
<b>Notes:</b>		
<b><u>a</u></b> Data for excavation, other outside forces, and natural forces damage are from table 4.12.2-1.		
<b><u>b</u></b> The numbers in this report have been rounded for presentation purposes. As a result, the totals do not reflect the sum of the addends.		

Older pipelines have a higher frequency of outside forces incidents, in part because their locations may be less well known and less well marked than newer lines. In addition, the older pipeline systems contain a disproportionate number of smaller diameter pipelines, which have a greater rate of outside forces incidents because they are more easily crushed or broken by mechanical equipment or earth movements.

Since 1982, operators have been required to participate in “One Call” public utility programs in populated areas to minimize unauthorized excavation activities in the vicinity of pipelines. The “One Call” program is a service used by public utilities and some private sector companies (e.g., oil pipelines and cable television) to provide pre-construction information to contractors or other maintenance workers on the underground location of pipes, cables, and culverts.



### 4.12.2.3 Impacts on Public Safety

The incident data summarized in tables 4.12.2-1 and 4.12.2-2 include pipeline failures of all magnitudes, with widely varying consequences. Table 4.12.2-3 presents the average annual injuries and fatalities that occurred on natural gas transmission lines between 2009 and 2013. The data have been separated into employees and nonemployees, to better identify a fatality rate experienced by the general public. In addition, PHMSA (2014) reported that fatalities for natural gas transmission lines averaged two per year over the 20-year period from 1994 through 2013.

Year	Injuries		Fatalities	
	Employees	Public	Employees	Public
2009	4	7	0	0
2010 <sup>b</sup>	10	51	2	8
2011	1	0	0	0
2012	3	4	0	0
2013	0	2	0	0
<b>TOTAL</b>	<b>18</b>	<b>64</b>	<b>2</b>	<b>8</b>

**Notes:**

<sup>a</sup> Source: DOT PHMSA, Pipeline Safety Stakeholder Communications, Significant Pipeline Incidents; [http://primis.phmsa.dot.gov/comm/reports/safety/cpi.html?nocache=4675#\\_ngtrans](http://primis.phmsa.dot.gov/comm/reports/safety/cpi.html?nocache=4675#_ngtrans). Accessed July 16, 2014.

<sup>b</sup> All of the public injuries and fatalities in 2010 resulted from the Pacific Gas and Electric Company pipeline rupture and fire in San Bruno, California, on September 9, 2010.

The majority of fatalities from pipelines involve local distribution pipelines. These are natural gas pipelines that are not regulated by the FERC and that distribute natural gas to homes and businesses after transportation through interstate natural gas transmission pipelines. In general, these distribution lines are smaller diameter pipes, often made of plastic or cast iron rather than welded steel, and tend to be older pipelines that are more susceptible to damage. In addition, distribution systems do not have large rights-of-way and pipeline markers common to the FERC-regulated natural gas transmission pipelines.

The nationwide totals of accidental fatalities from various manmade and natural hazards are listed in table 4.12.2-4 to provide a relative measure of the industry-wide safety of natural gas transmission pipelines. Direct comparisons between accident categories should be made cautiously, however, because individual exposures to hazards are not uniform among all categories. This comparison indicates that the number of fatalities resulting from natural gas pipeline incidents is more than 25 times lower than the total fatalities from natural hazards such as lightning, tornados, floods, and earthquakes.

The available data show that natural gas transmission pipelines continue to be a safe, reliable means of energy transportation. From 1994 through 2013, there was an average of 62 significant incidents and 2 fatalities per year. The number of significant incidents over the more than 300,000 miles of natural gas transmission lines indicates that the risk is low for an incident at any given location. As described above, the Pipeline Expansion would be constructed and operated in accordance with the DOT requirements; therefore, we believe that operation of the Pipeline Expansion would be safe and would represent only a slight increase in risk to the nearby public.

**TABLE 4.12.2-4**

**Nationwide Accidental Deaths**

Type of Accident	Annual Number of Deaths
All accidents <u>a</u>	122,777
Motor vehicle <u>a</u>	34,677
Falls <u>a</u>	26,631
Drowning <u>b</u>	3,555
Fire, smoke inhalation, burns <u>b</u>	2,621
Poisoning <u>a</u>	33,554
Floods <u>b</u>	113
Tornado <u>b</u>	553
Lightning <u>b</u>	26
Natural gas transmission pipelines <u>c</u>	2
<p><b>Notes:</b></p> <p><u>a</u> National Vital Statistics Reports, Deaths: Preliminary Data for 2011, Vol. 61, No 6, October 10, 2012.</p> <p><u>b</u> NOAA National Weather Service, Office of Climate, Water and Weather Services, Summary of Natural Hazard Statistics for 2011 in the United States, May 8, 2012, <a href="http://www.nws.noaa.gov/om/hazstats/sum11.pdf">http://www.nws.noaa.gov/om/hazstats/sum11.pdf</a></p> <p><u>c</u> DOT PHMSA, Significant Pipeline Incidents Summary Statistics: 1994–2013, May 2, 2013, <a href="http://primis.phmsa.dot.gov/comm/reports/safety/sigpsi.html?nocache=3174#_ngtrans">http://primis.phmsa.dot.gov/comm/reports/safety/sigpsi.html?nocache=3174#_ngtrans</a>.</p>	

**4.13 CUMULATIVE IMPACTS**

Cumulative impacts may result when the environmental effects associated with a proposed project are added to impacts associated with past, present, or reasonably foreseeable future projects. Although the individual impact of each separate project might not be significant, the additive or synergistic effects of multiple projects could be significant.

This cumulative impacts analysis uses an approach consistent with the methodology set forth in relevant guidance (CEQ, 1997b, 2005; EPA, 1999), and focuses on potential impacts from the proposed projects on resource areas or issues where their incremental contribution would be potentially significant when added to the potential impacts of other actions. To avoid unnecessary discussions of insignificant impacts and projects and to adequately address and accomplish the purposes of this analysis, an action must first meet the following three criteria to be included in the cumulative analysis:

- affect a resource potentially affected by the proposed Project;
- cause this impact within all, or part of, the geographic Project area; and
- cause an impact within all, or part of, the time span for the potential impact from the proposed Project.

Table 4.13.1-1 lists present and reasonably foreseeable future actions that may, when added to the effects of past actions and the effects of construction and operation of the Project, result in a cumulative effect on environmental resources. These actions were identified based on information provided by Golden Pass; internet research; stakeholder comments; and communications with federal, state, and local agencies.

**TABLE 4.13.1-1**

**Past, Present, and Reasonably Foreseeable Actions Considered in the Cumulative Impact Analysis for the Golden Pass LNG Export Project a b**

Action	Description	Distance from Project	Timeframe			Primary Relevant Resources
			Past	Present	Future	
Golden Pass LNG Terminal and Pipeline	LNG terminal and pipeline system in Jefferson and Orange Counties, TX, and Calcasieu Parish, LA	0 mile from Terminal	X			AR, GS, GW, LS, LU, SW, VW, W
Cameron LNG Terminal	LNG terminal and pipeline system in Cameron, Calcasieu, and Beauregard Parishes, LA	40 miles from Terminal	X	X	X	None anticipated
Cameron Liquefaction Project	LNG export terminal, 21-mile-long pipeline, and Holbrook Compressor Station consisting of 12 natural gas-driven compressors in Cameron, Calcasieu, and Beauregard Parishes, LA	40 miles from Terminal 17 miles from MP 66			X	A
Sabine Pass LNG Terminal	LNG terminal and pipeline system in Cameron Parish, LA	2 miles from Terminal	X	X	X	N, AR, RT, S, VT
Sabine Pass Liquefaction Project	Addition of liquefaction and associated facilities to the Sabine Pass LNG Terminal in Cameron Parish, LA, including Gillis Compressor Station	2 miles from Terminal 30 miles from MP 66		X	X	N, AR, RT, S, VT
Sabine Pass Liquefaction Expansion Project	Construction of two additional liquefaction trains at the facilities of the Sabine Pass LNG Terminal in Cameron Parish, LA	2 miles from Terminal		X	X	N, AR, RT, S, VT

**TABLE 4.13.1-1 (continued)**

**Past, Present, and Reasonably Foreseeable Actions Considered in the Cumulative Impact Analysis for the Golden Pass LNG Export Project a b**

Action	Description	Distance from Project	Timeframe			Primary Relevant Resources
			Past	Present	Future	
Lake Charles LNG Terminal	LNG terminal and pipeline system in Calcasieu Parish, LA	46 miles from Terminal 24 miles from MP 66	X	X	X	A
Lake Charles Liquefaction Project	Addition of liquefaction and associated facilities to the Trunkline LNG Terminal; three new pipelines ranging from 0.47 to 16.4 miles in length, new compressor station, and upgraded compressor stations; in Calcasieu and Beauregard Parishes, LA	46 miles from Terminal		X	X	None anticipated
Magnolia LNG Export Terminal	LNG export terminal in Calcasieu Parish, LA	43 miles from Terminal			X	None Anticipated
Tennessee Gas Pipeline	Interconnection and compressor station at MP 63	0 mile from MP 63	X	X	X	A, N, GS, GW, LS, LU, N, SW, VW, W
Transcontinental Gas Pipeline	Interconnection at MP 68	0 mile from MP 68	X	X	X	A, N, GS, GW, LS, LU, N, SW, VW, W
Texoma Pipeline Company Pipeline	Interconnection and compressor station at MP 33	0 mile from MP 33	X	X	X	A, N, GS, GW, LS, LU, N, SW, VW, W
Natural Gas Pipeline Company of America Pipeline	Interconnection at MP 1	0 mile from MP 1	X	X	X	A, N, GS, GW, LS, LU, N, SW, VW, W
Texas Eastern Transmission Company Pipeline	Interconnection and compressor station at MP 66	0 mile from MP 66	X	X	X	A, N, GS, GW, LS, LU, N, SW, VW, W

**TABLE 4.13.1-1 (continued)**

**Past, Present, and Reasonably Foreseeable Actions Considered in the Cumulative Impact Analysis for the Golden Pass LNG Export Project a b**

Action	Description	Distance from Project	Timeframe			Primary Relevant Resources
			Past	Present	Future	
Chevron Philips Chemical Company Facility	Receives liquefied petroleum gas and light blending aromatics by barge in Port Arthur, TX	5.7 miles from Terminal	X	X	X	A
Port Arthur Valero Refinery	Refinery to process heavy sour crude oil, with throughput capacity of 310,000 barrels per day (bpd) and a coker able to produce 85,000 bpd, in Port Arthur, TX	6.8 miles from Terminal	X	X	X	A
Enterprise Products Marine Terminal	Export terminal for refined petroleum products in Beaumont, TX	19 miles from Terminal 3 miles from MP 33	X	X	X	A
G2X Energy Natural Gas-to-Gasoline Plant	Plant to convert natural gas-to-gasoline in Lake Charles, LA	44 miles from Terminal 22 miles from MP 66			X	A
Natgasoline Methanol Production Plant	Methanol production plant with a capacity of 1.75 million tons per year in Beaumont, TX	18 miles from Terminal 4 miles from MP 33			X	A
Sabine Neches Waterway Channel Deepening Project	Channel dredging in Sabine-Neches Waterway	0 mile from Terminal			X	AR, LS, R, SW, VT, W
Chennault International Airport Expansion	Aircraft maintenance, repair, and overhaul facility at Chennault International Airport in Lake Charles, LA	28 miles from MP 66 51 miles from MP 33 56 miles from Terminal			X	A

**TABLE 4.13.1-1 (continued)**

**Past, Present, and Reasonably Foreseeable Actions Considered in the Cumulative Impact Analysis for the Golden Pass LNG Export Project a b**

Action	Description	Distance from Project	Timeframe			Primary Relevant Resources
			Past	Present	Future	
Farm to Market Road 299	New 6.2-mile-long, two-lane location arterial roadway from Vidor to Rose City in Orange County, TX	4 miles from MP 33			X	RT
Land transportation	I-10, SH-73, SH-82, SH-87	25, 10, 8, and 0 miles from Terminal, respectively	X	X	X	RT
Natural gas liquid transport by truck from Golden Pass LNG Export Terminal	Non-jurisdictional truck traffic outside of the Terminal Expansion transporting natural gas liquid from the site; truck volume is expected to be less than five trucks per day	0 mile from Terminal			X	RT
Tie-in to City of Port Arthur Water Supply	Non-jurisdictional tie-in to water supply for the proposed Terminal Expansion	0 mile from Terminal			X	GW
Notes:						
<b>a</b> This table is not intended to provide an all-inclusive listing of projects; however, it does list those projects with the most potential to contribute to cumulative impacts in the vicinity of the Project.						
<b>b</b>						
A – Air						
AR – Aquatic Resources						
GS – Geology and Soils						
GW – Groundwater						
LS – Listed Species						
LU – Land Use						
N – Noise						
R – Recreation						
RT – Road Traffic						
S – Socioeconomics						
SW – Surface Water						
VW – Vegetation and Wildlife						
VT – Vessel Traffic						
W – Wetlands						

The assessment (or geographic) area of potential cumulative impacts includes the area directly affected by Project construction, in addition to the area of potential cumulative effects to the same resource from other projects. The cumulative impact area assessed varies by resource. Effects to geology and soil resources are not likely to extend beyond the immediate vicinity of the Project area boundaries. Therefore, the cumulative impact area for geology and soil resources would be limited to areas adjacent to the Project area boundaries. Cumulative impacts on air quality are likely to extend beyond the Project area's boundaries. Cumulative impacts on water quality would extend to watershed boundaries. The cumulative impact area for socioeconomics would include the counties in which the proposed Project would be constructed and operated.

For the purposes of this analysis, the temporal extent of cumulative actions would start in the recent past and extend out for the expected physical operational service life of the projects considered (50 years). "Reasonably foreseeable actions" are proposed actions or developments that have applied for a permit from local, state, or federal authorities or that are publicly known.

#### **4.13.1 Projects and Activities Considered**

There are many existing, under construction, planned, and reasonably foreseeable projects in the vicinity of the Golden Pass LNG Export Project. There are also agriculture and silviculture activities that occur in the Project area. Table 4.13.1-1 lists the substantial projects and activities we considered in this cumulative impact analysis.

CEQ regulations require agencies to consider environmental effects of proposed actions, including direct and indirect effects, if these effects are reasonably foreseeable. The FERC does not consider effects from production associated with additional shale gas development as "reasonably foreseeable." We also do not evaluate end user cumulative impacts of the LNG exports as it is not possible to know who those end users would be, or for the FERC to realistically be able to characterize those impacts (especially in foreign countries, where environmental constraints would be different from the U.S. permitting process). Thus determining the end users and associated impacts is not reasonably foreseeable.

#### **4.13.2 Potential Cumulative Impacts by Resource**

The following sections address the potential cumulative impacts of the Golden Pass LNG Export Project and the other projects identified within the cumulative impact area for specific environmental resources. The other projects considered in each section are those for which impacts on the resource(s) discussed would be within the cumulative impact areas of the Golden Pass LNG Export Project and would occur within the same timeframe.

##### **4.13.2.1 Geologic Conditions**

The cumulative impact area for geologic resources and hazards was considered to be the area adjacent to construction areas for the Terminal Expansion and the Pipeline Expansion.

At the Terminal Expansion site, Golden Pass would modify the existing topographic contours to accommodate its equipment and facilities and to maintain adequate drainage from the site. This would result in contours similar to those of the adjacent existing Golden Pass Import Terminal and would not differ substantially from the existing topography. However, shoreline erosion due to waves, currents, and the wake of large vessels transiting the channel is prevalent along the Terminal Expansion site and the shoreline of the SNWW. To attempt to maintain the existing topographic contours along the shoreline, the existing shoreline protection system would be expanded, and areas of the existing protection system would

be upgraded and/or retrofitted. We conclude that these proposed mitigation measures would minimize erosion and scour impacts.

Construction and operation of the Pipeline Expansion would occur largely within previously disturbed areas, and Golden Pass does not anticipate any blasting along the right-of-way. The Pipeline Expansion would minimally affect geological resources because Golden Pass would restore topographic contours along the right-of-way to pre-construction conditions, to the extent practicable. These contours would tie-in to the existing easements that Golden Pass would parallel. No other projects adjacent to the construction area for the Pipeline Expansion would result in changes of topography. Therefore, the cumulative impact of the Pipeline Expansion on geologic resources would be minor.

In addition, the Project would not affect marketable mineral resources and therefore would not contribute to cumulative impacts on those resources.

#### **4.13.2.2 Soils**

The cumulative impact area for soils was considered to be the area adjacent to construction areas for the Terminal Expansion and the Pipeline Expansion. Past impacts on soils resources in the vicinity of the Project have resulted from events such as construction of the existing Golden Pass Import Terminal and existing Golden Pass Pipeline; dredging, widening, and deepening of the SNWW; construction and maintenance of existing roads, railroads, and natural gas and oil pipelines; and agricultural and commercial forestry processes.

Various components of the SNWW Deepening Project and the Terminal Expansion would entail dredging the SNWW in the vicinity of the Terminal Expansion site. Dredging during Terminal Expansion construction and operation would be required for installation of the shoreline protection revetment and Supply Dock; maintenance dredging for the Supply Dock and Ship Slip; and development of the access channel and temporary float channels (see sections 2.2.1.5 and 2.2.1.7). Dredging is a routine and ongoing practice along the SNWW. Given the relative size of the dredging activities proposed, the amount of increased sediment removal resulting from Project-related dredging would be minor relative to what is common in the SNWW. Consequently, any potential cumulative effects to the SNWW sediments are anticipated to be minor.

Clearing and grading associated with construction of the Terminal Expansion and the Pipeline Expansion could result in soil loss from erosion, which could reduce soil fertility and impair revegetation. However, Golden Pass would implement the measures required by FERC's Plan and Procedures to minimize erosion as a result of water and wind and aid in reestablishment of vegetation in work areas that would not be maintained in an industrial state after construction. In addition, the Terminal Expansion and Pipeline Expansion facilities would be adjacent to and integrated with the existing Golden Pass Import Terminal and Golden Pass Pipeline footprints and with existing third-party natural gas infrastructure and rights-of-way, thereby minimizing impacts on previously undisturbed areas to the extent practicable. As a result, we do not anticipate a significant cumulative impact on soils or sediments from construction and operation of the Project.

#### **4.13.2.3 Water Resources**

The cumulative impact area established for groundwater resources was limited to the aquifers from which the Project would withdraw water. The cumulative impact area associated with surface water resources extends about 2 miles upstream and downstream of the Terminal Expansion site boundaries. This distance was selected as the distance within which suspended sediments would be expected to settle within the water column and be re-deposited, and is considered a conservative estimate based on the relatively low



flow rates of the SNWW. Potential cumulative impacts on surface water are related to dredging, shoreline erosion, and marine traffic with associated ballast water discharges.

Golden Pass would obtain water for construction of the Terminal Expansion from the City of Port Arthur municipal line or by purchasing raw water. Construction needs would include water required for hydrostatic testing of the facility piping to verify the integrity of the facilities prior to placing them into service. According to the East Texas Regional Water Plan, the southeast region of Texas as a whole appears to have enough supply to meet demands through 2040, and recommended water management strategies result in additional water supply available to meet most projected needs for the region by 2060 (TWDB, 2012). Thus, adequate water is available for the planned uses at the Terminal Expansion, and we conclude that the cumulative impact on water supplies during construction would not be significant.

During operation, Golden Pass also would obtain water from the City of Port Arthur. However, operation of the Project would require substantially less water than construction. In addition, no other cumulative project listed in table 4.13.1-1 is known to require water from the City of Port Arthur. Consequently, we conclude that the Project would not result in a significant cumulative impact on the municipal water system.

Construction of the shoreline protection revetment would include dredging about 86,700 yd<sup>3</sup> of material to provide access channels for construction equipment. Golden Pass would expand the existing shoreline protection system by constructing about 5,500 feet of new rock revetment to stabilize the actively eroding shoreline. The expansion of the shoreline protection system would entail clearing and grading the shoreline where the new revetment would be installed. Golden Pass also would dredge an access channel about 14 feet deep and 200 feet wide parallel to the shoreline immediately west of the Supply Dock to position a barge that would be used as a floating dock at the shoreline. The access channel would be dredged or excavated on an as-needed basis for the duration of construction of the Terminal Expansion.

Construction of the Supply Dock and access channel would include dredging about 368,750 yd<sup>3</sup> of substrate in waters adjacent to the shoreline. Dredging for the shoreline protection revetment, Supply Dock, and the access channel would result in impacts similar to those that occurred during construction of the existing terminal's ship berthing area and turning basin by Golden Pass and during routine maintenance dredging of the SNWW by the COE. Golden Pass would adhere to the measures included in FERC's Procedures and COE permits to minimize impacts from dredging. The impact would be minor and temporary when it did occur, and we conclude that turbidity would return to pre-dredging levels soon after dredging is completed.

Additional dredging would occur in the SNWW in the vicinity of the Terminal Expansion as part of the SNWW Deepening Project and maintenance dredging associated with the construction dock and marine berth of the Sabine Pass LNG Terminal. If the SNWW Deepening Project or routine maintenance dredging of the SNWW or the Sabine Pass LNG Terminal berthing area were to overlap with the dredging required for the Terminal Expansion, any cumulative effects to water quality are anticipated to be short term and minor, given the relatively small size of the dredging activities proposed for construction of the shoreline protection revetment, access channel, temporary float channels, and Supply Dock. Dredging is a routine, ongoing practice along the SNWW. Dredging-related impacts associated with those efforts and dredging for the proposed Project would be expected to be minor and temporary because of the methods used to minimize sediment suspension in the water column, the high ambient levels of turbidity in the channel, and the relatively rapid re-deposit of the suspended sediments.

Maintenance dredging of the SNWW is conducted on a regular basis (COE, 2012b). The FERC (2005) concluded that effects associated with maintenance dredging for the existing Golden Pass Import Terminal represented a minor, insignificant increase over what is common in the SNWW. Maintenance dredging associated with the Supply Dock is anticipated to be similar to the routine maintenance dredging

in the SNWW. We conclude that the potential cumulative effects on water quality from dredging would not be significant.

Shoreline erosion is a concern along the SNWW. Erosion may be caused by ship traffic or by engineered structures, such as levees along beaches or rivers. Natural processes, such as tide-induced currents, sea level changes, wind waves, and hurricanes or other extreme storms, also contribute to shoreline erosion. To minimize impacts from potential erosion and sedimentation in the SNWW due to land disturbance during construction and operation of the Terminal Expansion, Project activities would be conducted in accordance with the measures outlined in FERC's Plan and Procedures, and all Texas and Louisiana stormwater regulations and permitting requirements. As mandated by these plans, Golden Pass would implement measures, including installation and maintenance of all necessary erosion and sedimentation control structures to avoid impacts on the SNWW. During normal operation of the Terminal Expansion facilities, surface water discharges would consist of stormwater runoff. Stormwater runoff would collect in a series of stormwater outfalls, which would direct the water away from the site, in accordance with the Golden Pass SWPPP. We are not aware of any other substantial construction projects within the cumulative impact area for surface water runoff. As a result, we conclude a significant cumulative impact on surface water from runoff would not result from construction or operation of the Terminal Expansion.

Golden Pass does not plan to increase LNG carrier traffic during operation beyond that previously evaluated and approved for the existing terminal (FERC, 2005); therefore, the Project would not contribute to cumulative impacts related to vessel traffic beyond those previously assessed. The only increase in marine traffic associated with the Project would be temporary barge and support vessel traffic during construction. In addition, slopes along the new shoreline created for the Supply Dock would be protected by shoreline armoring to reduce the potential for shoreline erosion. The additional barge traffic could result in minor shoreline erosion, but we conclude that it would not contribute to a significant impact on shorelines.

Although few, if any, of the barges used for construction of the Project would have ballast systems, ballast water management (discharge and uptake) may nonetheless increase in the SNWW with the increase in vessel traffic. However, the captains of LNG carriers would be required to comply with ballast water management the procedures presented in 33 CFR 151 (Vessels Carrying Oil, Noxious Liquid Substances, Garbage, Municipal or Commercial Waste and Ballast Water) and 46 CFR 162.060 (Ballast Water Management Systems) as last revised in 2012, and the Coast Guard's Navigation and Vessel Inspection Circular 07-04, Change 1, dated October 29, 2004. These regulations set forth a limited number of acceptable ballast water management methods. As a result, we conclude that the contribution of ballast water discharge from the Project would not result in a significant cumulative impact on water quality.

The Pipeline Expansion would affect three waterbodies, including one agricultural ditch and two roadside ditches. We do not anticipate that the Pipeline Expansion would contribute to cumulative impacts on water quality in these waterbodies.

We did not identify any other project that would contribute to cumulative impacts on water resources from hydrostatic test water withdrawal and discharge in the cumulative impact areas of the Terminal Expansion and the Pipeline Expansion. Therefore, we conclude that cumulative impacts associated with withdrawal and discharge of hydrostatic test water would be temporary and minor.

#### 4.13.2.4 Wetlands

The cumulative impact area for wetlands was considered to be the area adjacent to the Project construction areas.

Construction of the Terminal Expansion would affect 381.4 acres of wetlands. Of this total, 372.5 acres would be permanently filled for facility operations. Operational impacts would affect 370.9 acres of PEM wetlands, 1.2 acres of PSS wetlands, and 0.4 acre of PFO wetland habitat (see table 4.4.2-1). However, the COE and the TGLO would require compensatory mitigation for wetland loss that would result in no net loss of wetland function and could improve regional coastal marsh resources. Golden Pass would mitigate wetland conversions as specified in its PRM Plan for wetland losses at the Terminal Expansion and MP 1 Compressor Station sites, to be approved by the COE as part of the Golden Pass COE permit applications for the Terminal Expansion. As mitigation, Golden Pass has proposed restoration of coastal marsh in the Salt Bayou Unit of the J.D. Murphree WMA (see section 4.4.3).

No projects adjacent to the site of the Terminal Expansion would affect wetlands. Any future project within the cumulative impact area of the Terminal Expansion would need to offset all unavoidable wetland impacts with compensatory mitigation. Consequently, we do not anticipate that construction and operation of the Terminal Expansion in combination with current or future projects would result in a significant cumulative impact on wetlands.

A total of 17.0 acres would be affected during construction of the Pipeline Expansion, including 16.8 acres of PEM wetlands and less than 0.1 acre of both PSS and PFO wetland habitat (see table 4.4.2-1). Of the affected acreage, 9.4 acres would be permanently disturbed during operations of the aboveground facilities (all PEM wetlands). Almost all of the permanently disturbed wetland habitat (8.8 acres) would be at the MP 1 Compressor Station and NGPL Interconnection adjacent to the Terminal Expansion. No wetland habitat would be permanently disturbed along the Calcasieu Loop except for areas associated with aboveground facilities.

Wetland impacts would be minimized by collocating the pipeline route with existing pipeline rights-of-way and through use of HDD technology. The COE, the TGLO, and the LDNR Office of Coastal Restoration and Management would require compensatory mitigation for wetland loss that would result in no net loss of wetland function and could improve regional coastal marsh resources. Golden Pass would mitigate wetland conversions as specified in the PRM Plan for wetland losses at the MP 33 Compressor Station, to be approved by the COE after review of the COE permit applications for the Pipeline Expansion. As mitigation, Golden Pass has proposed purchasing credits at a COE-approved wetland mitigation bank (see section 4.4.3).

Cumulative impacts on wetlands during operation would occur where the Pipeline Expansion is collocated with the permanent rights-of-way of the existing Golden Pass Pipeline, both cross the same wetland, and the wetlands are maintained by periodic mowing and tree removal. However, these wetlands were previously disturbed during construction of the existing pipeline, and the impacts were mitigated in accordance with the COE, the TGLO, and the LDNR requirements during or shortly after construction. Golden Pass is in the process of evaluating potential mitigation concepts. Because Golden Pass would compensate for wetland impacts, we conclude that the cumulative impact on wetlands from construction and operation of the Pipeline Expansion would not be significant.

#### 4.13.2.5 Vegetation and Wildlife

The cumulative impact area for vegetation and wildlife was considered to be the area adjacent to and near (within approximately 1 mile of) the Project construction areas.

The existing Golden Pass Import Terminal is adjacent to the Terminal Expansion site. Construction and operation of the existing terminal resulted in the loss of all vegetation (about 241 acres) and wildlife habitat on that site, as did construction and operation of adjacent SH-87. Construction of the Terminal Expansion would remove 485.7 acres of vegetation. The existing plant community in the vicinity of the Terminal Expansion is segmented and disturbed because of channel dredging, placement of dredge spoils, and past installation of linear transportation corridors (e.g., railroad bed [abandoned], drainage ditches, and buried pipelines) and is not considered high-quality wildlife habitat. Reviews of the TPWD and the Louisiana Natural Heritage Program Element Occurrence databases indicate that no federally- or state-listed natural communities are in the vicinity of the Terminal Expansion (BES, 2013c, 2013d; FERC, 2005). Further, the Terminal Expansion does not cross any areas designated by the FWS or NOAA Fisheries as critical habitat for any threatened or endangered species, nor does it cross any NOAA Fisheries-designated Habitat Areas of Particular Concern (NOAA, 2013c). However, sensitive (i.e., imperiled or rare) and noxious species may occur in the vicinity of the Terminal Expansion. Golden Pass would implement measures identified in its *Invasive Species Control Plan* to reduce the spread of invasive and non-native vegetation in temporarily affected areas, and would implement FERC's Plan and Procedures to minimize the potential for noxious weeds to be introduced into the soil during construction.

In addition, Golden Pass proposes to create coastal marsh wetland habitat as compensatory mitigation at a ratio of 1.96 acres for each acre of COE-jurisdictional wetland affected by the Terminal Expansion. Created marsh habitat would vegetate naturally and would benefit wildlife; Golden Pass would monitor the created habitat for quality and functionality for a period of 20 years. The *Wetland Mitigation Plan* would need to be approved by appropriate federal and state resource agencies. As a result, we believe that the cumulative impact on vegetation and wildlife from construction and operation of the Terminal Expansion would not be significant.

Past impacts on vegetation in the vicinity of the Pipeline Expansion route have resulted from agricultural and commercial forestry processes and construction and maintenance of existing roads, railroads, natural gas and oil pipelines, utility lines, and electrical transmission line rights-of-way. The proposed route is adjacent and parallel to rights-of-way of the existing Golden Pass Pipeline, and construction of the Pipeline Expansion would increase the width along a portion of that corridor. The Pipeline Expansion would not create an additional corridor or cause additional fragmentation. Most of the temporary construction right-of-way and ATWS adjacent to the proposed route would be allowed to revegetate to a vegetative state similar to pre-construction conditions, including forested areas not within the permanent right-of-way. During construction, mobile wildlife species would relocate to adjacent habitats, and we expect that the populations of most displaced species would return to about pre-construction levels along the right-of-way after restoration. Therefore, we conclude that construction and operation of the Pipeline Expansion and the existing Golden Pass Pipeline would not result in a significant cumulative impact on vegetation and wildlife.

#### 4.13.2.6 Aquatic Resources

We considered the cumulative impact area for aquatic resources to be the same as for water resources (2 miles upstream and downstream of the Terminal Expansion site boundaries). Dredging during construction of the Supply Dock, access channel, and temporary float channels would affect bottom-dwelling marine organisms and the bottom habitat within the dredged area. However, these communities generally repopulate within 1 year (MMS, 2004); as such, impacts on the benthic community from dredging would be short term and minor. Likewise, maintenance dredging of the Supply Dock would continue

periodically during the life of the Project and result in localized, short-term impacts on water quality and the benthic community when dredging occurs. Periodic maintenance dredging of the existing Golden Pass Ship Slip, the construction dock and marine berth at the Sabine Pass LNG Terminal, the SNWW by the COE, , and the SNWW Deepening Project would affect bottom habitat in the vicinity of the Terminal Expansion. Because of the substantial amount of subtidal habitat in the cumulative impact area, we conclude that the Project would result in a minor cumulative impact on aquatic species.

The impact of increases in turbidity from dredging associated with the Supply Dock, access channel, temporary float channels, and the existing Golden Pass Ship Slip, the construction dock and marine berth at the Sabine Pass LNG Terminal, the SNWW maintenance dredging by the COE, and the SNWW Deepening Project would be temporary and localized to the dredged areas and relatively short downstream distances. As a result, marine species are likely to experience localized effects. If dredging for the Project takes place at the same time as the aforementioned dredging activities, the geographic extent of the temporary impacts would increase beyond the area affected by dredging for the Project. If the dredging projects were not concurrent, the impact area would be smaller, but the duration of dredging impacts in the cumulative impact area would increase. In either case, we conclude that the impact from dredging in the cumulative impact area would not be significant because the impacts would be temporary and localized, as the turbidity would return to pre-dredging levels soon after dredging is completed.

The Pipeline Expansion would cross three ditches but would not cross any natural waterbodies and would not affect fisheries resources. Therefore, we conclude that the Pipeline Expansion would not contribute to cumulative impacts on fisheries resources.

#### **4.13.2.7 Threatened and Endangered Species**

The cumulative impact area associated with threatened and endangered species potentially affected by construction and operation of the Terminal Expansion and the Pipeline Expansion includes the areas adjacent to and in the vicinity of the Project, as well as the area encompassed by the marine transit route for the LNG carriers. A total of 41 species listed at the federal or state level as threatened, endangered, or candidate species occur in Jefferson and Orange Counties, Texas, and Calcasieu Parish, Louisiana. In section 4.7, we provide the life histories and effects determinations for the species with the potential to occur in the Project area.

The Project would not be within the known range or would not affect the habitat for 21 of the 41 species. The Terminal Expansion and Pipeline Expansion would have *no effect* on these species and therefore, we conclude, would not contribute to cumulative impacts on these 21 species (see table 4.7-1).

Suitable habitat for the remaining 20 species listed at the federal or state level as threatened, endangered, or candidate species may occur in the vicinity of the Project. Eight species are federally listed as endangered, threatened, or candidate species. They are the Atlantic hawksbill, Kemp's ridley, leatherback, green, and loggerhead sea turtles; and the American alligator<sup>56</sup>, piping plover and Sprague's pipit (see table 4.7-1). The 12 additional species are state listed as threatened, endangered, or candidate species. They are the bald eagle, alligator snapping turtle, American peregrine falcon, Rafinesque's big-eared bat, reddish egret, swallow-tailed kite, timber/canebrake rattlesnake, white-faced ibis, wood stork, Gulf salt marsh snake, and Texas diamondback terrapin. The Sprague's pipit is also a candidate for listing in Louisiana (see table 4.7-2).

Based on consultation with the FWS, NOAA Fisheries, the TPWD, and the LDWF, we conclude that the Terminal Expansion is *not likely to adversely affect* any of the species federally-listed as endangered

---

<sup>56</sup> The American alligator is listed due to similarity in appearance to the threatened American crocodile.

or threatened. Likewise, we conclude that impacts on the state-listed, threatened, endangered, and candidate species would be unlikely.

Sabine Pass LNG completed Section 7 of the ESA consultation with the FWS, NOAA Fisheries, and the LDWF regarding the Sabine Pass Liquefaction and Sabine Pass Liquefaction Expansion Projects. The agencies concurred that the project was *not likely to adversely affect* threatened and endangered species. The SNWW Deepening Project also would need to complete Section 7 of the ESA consultation but is not anticipated to adversely affect threatened or endangered species. Consequently, we conclude that construction and operation of the Terminal Expansion, Sabine Pass Liquefaction and Sabine Pass Liquefaction Expansion Projects, and the SNWW Deepening Project are not likely to cause significant cumulative impacts on the listed species in the Project vicinity.

No other projects are under construction, planned, or reasonably foreseeable in the vicinity of the Pipeline Expansion; therefore, we conclude that cumulative impacts on threatened or endangered species from construction and operation of the Pipeline Expansion would not be significant.

#### **4.13.2.8 Land Use, Visual Resources, and Recreation**

##### **Land Use**

The cumulative impact area for land use was considered to be the area adjacent to and in the vicinity of the Project.

The existing Golden Pass Import Terminal site is classified as industrial land. Construction of the Terminal Expansion would affect lands classified as industrial, wetlands, forested, unvegetated water bottom, and open water land uses. After construction, lands within the expanded terminal fence line would be classified as industrial. The MP 1 Compressor Station would be sited on lands with similar land use types as the Terminal Expansion. The Terminal Expansion and MP 1 Compressor Station would be constructed adjacent to the existing Golden Pass Import Terminal and near other industrial facilities (i.e., the Sabine Pass Liquefaction and Sabine Pass Liquefaction Expansion Projects) in the vicinity. Because many areas of wetlands, forest, and open water are adjacent to the site, we conclude that the Terminal Expansion would not result in a significant cumulative impact on land use.

Construction of the Pipeline Expansion would affect industrial, open space, wetlands, forested, agricultural, and silvicultural land uses as described in section 4.8. The MP 33 Compressor Station would be constructed adjacent to the existing Golden Pass Pipeline corridor on lands classified predominately as forested land, with some open land. The MP 66 Compressor Station would be constructed in a remote area on pine plantation lands, also adjacent to the existing Golden Pass Pipeline corridor. No other projects were identified in the immediate vicinity of the Pipeline Expansion. As a result, we conclude that the cumulative impact on land use from construction and operation of the Pipeline Expansion would not be significant.

##### **Visual Resources**

The cumulative impact area for visual resources was considered to be the area within the viewsheds of the Project facilities. Because of the height of the structures at the Terminal Expansion, the viewshed of the terminal would extend for several miles in all directions. The viewshed for the Pipeline Expansion is about 0.5 mile from the pipeline corridor and the aboveground facilities.

The Terminal Expansion and the MP 1 Compressor Station would be similar to and consistent with the visual character of the existing, adjacent Golden Pass Import Terminal and other industrial facilities along the industrialized SNWW. Both the Terminal Expansion and the Sabine Pass LNG Terminal and its

related expansion projects would entail construction and operation activities along the SNWW, and would be anticipated to result in a minor incremental change to the visual character of the area.

The other proposed projects or projects under construction within the viewshed of the Terminal Expansion (i.e., the SNWW Deepening Project) primarily involve dredging. If the construction schedules of these projects were to overlap with construction of the Terminal Expansion, views from Pleasure Island, SH-87, and Sabine Pass could include dredging equipment and Terminal Expansion construction equipment, in addition to the new Terminal Expansion facilities. However, the presence of dredging equipment in the SNWW would be temporary, and the equipment would not remain in an area for a long period. Based on the industrial nature of the SNWW, the visual impacts would be anticipated to be minor.

Construction of the Terminal Expansion, the authorized LNG facilities at the Sabine Pass LNG Terminal, and the SNWW Deepening Project would increase vessel traffic in the SNWW. This could result in a cumulative visual effect on the SNWW viewshed. However, the increases would be minor in comparison to existing traffic; and the increases from the Terminal Expansion would last only for the duration of construction. Golden Pass has not proposed an increase in the number or size of LNG carriers calling on the terminal during operation and therefore would not contribute to cumulative impacts on vessel traffic and the attendant visual impacts. As a result of these considerations, we conclude that the contribution of construction vessel traffic for the Terminal Expansion would not result in a cumulative impact on visual quality.

We did not identify any other proposed major projects within the same viewshed as the Terminal Expansion. As a result, we believe that the cumulative impact on visual resources would not be significant.

The facilities of the Pipeline Expansion in Jefferson and Orange Counties, Texas, and in Calcasieu Parish, Louisiana, would not occupy the same viewshed as any of the other projects identified in table 4.13.1-1, except for the Golden Pass Pipeline corridor, because of geographic separation or the presence of forested lands. Therefore, the minor, localized visual impacts of the Pipeline Expansion would not contribute to a significant cumulative impact on visual resources.

### **Recreation**

For the Terminal Expansion, the cumulative impact area for recreational-use vessels was considered to be the SNWW and associated embayments in the vicinity of construction and operational vessel traffic. The cumulative impact area for recreational facilities for both the Terminal Expansion and the Pipeline Expansion was considered to be Jefferson and Orange Counties, Texas, and Calcasieu Parish, Louisiana.

In the initial phases of construction of the Terminal Expansion, the increase in barge traffic may affect some recreational and commercial users of the waterway, resulting in a short-term impact. Continued barge traffic may be associated with construction of the authorized facilities at the Sabine Pass LNG Terminal and vessels associated with maintenance dredging at the Terminal Expansion, Sabine Pass LNG Terminal, and in the SNWW by the COE, in addition to the SNWW Deepening Project. However, recreational vessels currently encounter many barges and other ships using the SNWW. Further, the cumulative impact of increased Project-related vessel traffic in the waterway during construction would be short term. Therefore, we conclude that cumulative impacts on boat traffic would not be significant.

Marine vessel traffic during operation of the Project would be minimal and would not contribute to impacts on the SNWW. Golden Pass does not plan to increase the number or size of the LNG carriers that were previously evaluated for the Golden Pass Import Terminal. Therefore, we conclude that operations of the Terminal Expansion would not contribute to cumulative impacts on recreational vessel traffic in the SNWW or nearby waterways.

As described in section 4.9, most of the Terminal Expansion construction workers from out of the area are expected to reside in Orange and Jefferson Counties, Texas, and in Cameron and Calcasieu Parishes, Louisiana. Some of the workers may bring their families. It is likely that many of those workers, and in some cases their families, would use the recreational facilities and other recreational opportunities available in the area. Although this occasionally may stress some individual recreational facilities, we do not expect the cumulative impact to be significant because of the large geographic area in which the workers would be housed and the number of recreational opportunities within that area.

#### **4.13.2.9 Socioeconomics**

##### **Socioeconomic Conditions**

We considered the cumulative impact area for socioeconomics to include Jefferson and Orange Counties, Texas, and Calcasieu Parish, Louisiana,<sup>57</sup> where Golden Pass would construct its facilities and workers would likely reside during construction and operation of the Project.

Construction of the Project would add temporary employment opportunities in the area, resulting in a minor, temporary decrease in the unemployment rate for the Project area. Competition for a construction workforce between the Project and the other projects listed in table 4.13.1-1 would be expected to be minor because the majority of the projects are considered to be at the maximum commuting distance from the site of the Project. The authorized projects at the Sabine Pass LNG Terminal are anticipated to have the largest amount of overlap in need for workers during Project construction. The Sabine Pass LNG Terminal and the Golden Pass Import Terminal were constructed simultaneously without noticeable effects to the labor force. Similarly, potential cumulative effects on employment related to simultaneous construction of the Sabine Pass Liquefaction Project and the Project are anticipated to be minor.

The influx of non-local workers for construction and operation of the Terminal Expansion would not affect transient housing in Jefferson County. As described in section 4.9.4.1, a peak workforce of about 2,900 workers would be required for the Terminal Expansion. Assuming that the entire workforce was not local, the combination of vacant rental units and hotel/motel rooms would accommodate the required workforce. As described in section 4.9.4.2, the peak workforce that would be required for the Pipeline Expansion is estimated to be 500 workers. The available housing units for rent and the other housing options in the Project area would be expected to accommodate the construction workforce for the Pipeline Expansion.

Golden Pass expects that at least 40 percent of the construction workforce and 100 percent of the operational workforce would be hired from within the local region and therefore would not need new housing. Consequently, the impacts on housing during construction and operation along with the impacts from other cumulative projects would not result in a significant cumulative impact.

The combined construction workforces of projects would increase the need for some public services, such as police, medical services, and schools. However, this increase would be spread throughout the cumulative impact area for socioeconomics and would not result in a significant cumulative impact on public services. While construction of the Terminal Expansion would result in a temporary impact on the population in Jefferson County and a minimal impact on populations in Orange County and Calcasieu Parish, Golden Pass states that it would continue to coordinate with local municipalities in proximity to the Terminal Expansion and Pipeline Expansion to ensure that emergency response plans are integrated with existing service providers. If the medical and emergency services or other public services are adversely affected during construction, the project sponsors may mitigate the impact by providing funding for

---

<sup>57</sup> As noted in section 4.9, for the socioeconomic analysis, these two counties and one parish are considered the "Project area."



temporarily increasing the staff and equipment of the public services affected. As a result, we conclude that the Project would not result in a significant cumulative impact on emergency or medical services.

Increases in school enrollment would be limited to the number of non-local work force families relocating to the Project area and likely would be spread out among many schools and across many grade levels. In addition, the increases in school attendance due to construction of the authorized projects at the Sabine Pass LNG Terminal are being absorbed, and further increases would be minor at most. Therefore, we conclude that the Project would not result in a significant cumulative impact on local schools.

Both southeast Texas and southwest Louisiana, generally, and Jefferson County, Orange County, and Calcasieu Parish, specifically, are likely to experience cumulative benefits from the combined direct (e.g., jobs and local expenditure) and indirect (e.g., demand for goods and services of other businesses) economic stimulus provided by construction and operation of the Project and construction and/or operation of the other major projects listed in table 4.13.1-1.

### **Marine Transportation**

The cumulative impact area for marine transportation associated with the Terminal Expansion was considered to be the SNWW northward to its confluence with the Gulf Intracoastal Waterway and southward to the Gulf of Mexico.

As previously described, construction of the Terminal Expansion, the authorized projects at the Sabine Pass LNG Terminal, and the SNWW Deepening Project are likely to temporarily increase barge and support vessel traffic in the SNWW. Concurrent construction of these three projects likely would result in a cumulative impact on vessel traffic in the waterway, primarily by increasing vessel travel times due to congestion. However, the vessel traffic increase from the Project would be a small percentage of the volume of vessel traffic commonly present on the SNWW. As a result, we conclude that there would not be a significant cumulative impact on vessel traffic in the waterway during construction.

Golden Pass does not plan to increase the number or size of LNG carriers previously evaluated for the Golden Pass Import Terminal, and operation of the Project would not contribute to a cumulative impact on marine traffic beyond that previously assessed.

### **Land Transportation**

We considered the cumulative impact area for land transportation to include Jefferson and Orange Counties Texas and Calcasieu Parish, Louisiana, wherein the Project facilities would be located and the construction workers for the Project typically would reside.

In Jefferson County, large-volume highways (e.g., Interstate 10 and SH-73) readily connect to the Terminal Expansion site area via SH-87. However, according to representatives of the Texas DOT, the current condition of SH-87 precludes use of the roadway to transport large, heavy equipment and materials. Therefore, the proposed method for such deliveries would be via barges on the SNWW. This approach would limit the overall traffic volume on SH-87.

Potential cumulative effects from traffic related to the Terminal Expansion likely would occur during the daily changes in shift workers at the Valero Refinery and Chevron Phillips facilities on SH-82 in Port Arthur. To minimize construction worker vehicle trips to the Terminal Expansion site and thereby minimize traffic delays, Golden Pass would establish satellite parking locations and a shuttle service that would transport workers to the Terminal Expansion construction area. No satellite parking areas have been secured at the time this EIS was prepared; however, Golden Pass anticipates obtaining parking areas in the general area of the Motiva Refinery north of SH-82, in the vicinity of the City of Port Arthur, and potentially at sites along SH-73 between the cities of Port Arthur and Winnie. Golden Pass would consider using off-

duty peace officers to ensure that the traffic flow into and out of the satellite lots does not significantly affect normal traffic flow and would work with the Jefferson County Sheriff Department and City of Port Arthur to ensure that public safety is not jeopardized and traffic disruptions are kept to a minimum. In addition, work times for the Terminal Expansion construction would be shifted to ease traffic flow on SH-82 to account for school- and commuter-related traffic from residences and businesses in Sabine Pass. Therefore, we conclude that cumulative effects to traffic along roadways in the vicinity of the Terminal Expansion, including SH-82 and SH-87, would not be significant.

In Orange County and Calcasieu Parish, the only project that appears to have the potential for a cumulative effect on traffic with the Pipeline Expansion would be temporary alterations to the traffic patterns at the intersection of FM 105 and the proposed FM 299 in Orange County near MP 33. However, the construction schedule for the FM 299 Project is currently unknown. If construction of the FM 299 Project were to overlap with that of the Pipeline Expansion, drivers could use alternate routes to avoid the construction zone. Because the direct construction areas for the two projects would not overlap, any cumulative effects to transportation would be within the City of Vidor and likely would be minor.

#### **4.13.2.10 Cultural Resources**

The cumulative impact area for cultural resources was considered to be the area adjacent to and near the Project. No cultural resources were identified during surveys completed for the Project. Therefore, the Project would not contribute to cumulative impacts on cultural resources.

#### **4.13.2.11 Air Quality and Noise**

##### **Air Quality**

The cumulative impact area for air quality during operation of the Project was established based on the expanded terminal's PSD area of impact of 6.2 miles (about 10 km). This area encompasses the authorized projects at the Sabine Pass LNG Terminal (currently under construction) and the SNWW Channel Deepening Project. Because the locations of the Terminal Expansion and the Pipeline Expansion span across southeast Texas and southwest Louisiana, the following discussion addresses the cumulative air quality impacts of these Project components separately.

##### Project Emissions

##### *Terminal Expansion*

Construction of the Terminal Expansion would temporarily affect air quality because of emissions from the combustion engines used to power construction equipment and fugitive dust associated with equipment movement on dirt roads and earth-disturbing activities. The primary projects in the vicinity of the Terminal Expansion with the potential to be conducted in a similar timeframe as the Terminal Expansion are construction of the Sabine Pass Liquefaction Project and implementation of the SNWW Channel Deepening Project. Based on the intermittent and short-term nature of these projects, we believe that construction of the Terminal Expansion would not contribute to a significant cumulative impact on air quality.

Although the region in the vicinity of the Project is in attainment with air quality standards, increases in industrial point sources could affect local and regional air quality. Under the TCEQ regulations, the expanded terminal would be considered a major emissions source, and its operation would contribute to cumulative impacts on air quality within the cumulative impact area.

The cumulative modeling analysis discussed in section 4.11.1 was performed to quantify emissions from operation of the Terminal Expansion. These emissions, in addition to existing major sources of air emissions in the cumulative area of impact, would not significantly affect air quality. While the Terminal Expansion would contribute to a cumulative impact on air quality in the PSD area of impact, as shown in the modeling analysis, this impact would not exceed the NAAQS, which were established to protect public health (including sensitive populations) and public welfare. In addition, Golden Pass would be required to comply with permit conditions during operation of the facility and incorporate the required controls to limit the emissions of certain criteria pollutants, HAPs, and GHGs. Projects that would be constructed in the future and are considered to be major sources of air emissions would be required to conduct a similar PSD analysis. Should evaluation of a new project result in a significant impact on air quality, the TCEQ would enforce operational limitations or require emissions controls that ensure the facility's compliance with the SIP and attainment with the NAAQS.

Golden Pass would minimize potential impacts on air quality associated with operation of the Terminal Expansion and MP 1 Compressor Station by adhering to applicable federal and state regulations and installing BACT to minimize emissions. The BACT analyses included as part of the PSD applications identify all applicable control technologies based on control effectiveness. The strictest controls are evaluated first and, if those are technically or economically infeasible—or if environmental effects are significant, then the next most stringent control technology is reviewed. The process continues until the BACT level being considered cannot be eliminated based on technical or economic considerations, energy, or environmental impacts.

Based on the cumulative modeling analysis described in section 4.11.1 and the required emissions controls, operations associated with the Terminal Expansion and MP 1 Compressor Station would not result in a significant cumulative impact on air quality.

In addition to emissions associated with operation of the Terminal Expansion and the authorized projects at the Sabine Pass LNG Terminal, air emissions from LNG marine traffic and other project-related vessels considered mobile sources of air emissions would occur from the boundary of territorial waters to the vessel berths. Based on the transitory nature of these mobile sources and the large area covered, we believe that the associated emissions would not cause a significant cumulative impact on air quality along the SNWW. Golden Pass has not requested an increase in the number of LNG carriers previously evaluated and approved for the existing Golden Pass Import Terminal; therefore, operation of the LNG carriers and any associated mobile sources would not contribute to a cumulative impact on the air quality of the area beyond that previously assessed. Although the number of LNG carriers calling on the existing terminal and the previously assessed vessel emissions would not increase, we evaluated emissions for total vessel operations as part of the cumulative impact analysis for the Terminal Expansion. As stated in section 0, the PSD air dispersion modeling screening results indicate that CO and PM<sub>2.5</sub> are below their respective PSD modeling SILs; therefore, further modeling was not required for these pollutants. The NO<sub>2</sub> screening resulted in levels greater than the SILs; therefore, refined modeling was conducted for NO<sub>2</sub>. Golden Pass revised the NSR modeling inputs to include emissions from vessel operations to verify the cumulative impacts that include emissions from the Terminal Expansion operations and associated mobile sources. Mobile source emissions were calculated for the LNG carriers while loading and while berthed at dockside without loading, for the LNG carriers while in transit, and for the tug assist vessels—both within and outside of the moored safety zone. The results of refined modeling indicated that NO<sub>2</sub> would not exceed any of the applicable NAAQS (see table 4.13.12-1). These mobile source emissions are not considered for permitting purposes by the EPA or the TCEQ.

**TABLE 4.13.12-1**

**NAAQS Full Impact Analysis for 1-hour NO<sub>2</sub> for Stationary and Mobile Sources during Operation of the Terminal Site a**

<b>Maximum Modeled NO<sub>2</sub> Concentration (µg/m<sup>3</sup>)</b>	<b>Background NO<sub>2</sub> Concentration (µg/m<sup>3</sup>)</b>	<b>Maximum Modeled plus Background Concentration (µg/m<sup>3</sup>)</b>	<b>NAAQS (µg/m<sup>3</sup>)</b>	<b>Below NAAQS (Yes or No)</b>
110.3	69.9	180.2	188.0	Yes
<b>Abbreviations:</b> µg/m <sup>3</sup> = micrograms per cubic meter NAAQS = National Ambient Air Quality Standards <b>Note:</b> a "Terminal Site" includes the Terminal Expansion, existing terminal, MP 1 Compressor Station, and mobile sources needed for operation (see footnote 31).				

Based on the modeling analysis, the cumulative impact on air quality associated with the Terminal Expansion and the existing mobile sources at the Golden Pass Import Terminal would not be significant.

*Pipeline Expansion*

The cumulative impact area for air quality during construction of the Pipeline Expansion is the area adjacent to and near the edge of the construction area for the pipeline and aboveground facilities. During construction of the Pipeline Expansion, combustion engines and fugitive dust would create temporary and minor impacts on air quality. There are no known cumulative projects that would be in the vicinity of the Pipeline Expansion. Nonetheless, Golden Pass would use certain measures such as watering the right-of-way to minimize construction-related emissions. Therefore, we conclude that the cumulative impact of construction on the local air quality would not be significant.

The cumulative impact areas for operation of the Pipeline Expansion are 32 miles (51 km) from each compressor station site. A cumulative modeling analysis was performed to quantify emissions from compressor station operations, in addition to existing major sources of air emissions in the cumulative impact areas. Air quality dispersion modeling was conducted for CO, NO<sub>2</sub>, PM<sub>10</sub>, and PM<sub>2.5</sub> for the MP 66 Compressor Station. The CO, PM<sub>10</sub>, and PM<sub>2.5</sub> screening levels were below the SILs; therefore, further refined modeling was not required for these pollutants. The NO<sub>2</sub> screening resulted in levels greater than the SILs; therefore, refined modeling was conducted for NO<sub>2</sub>. Major sources within the cumulative area of impact were modeled for the NO<sub>2</sub> annual average NAAQS run. The results of refined modeling indicated that NO<sub>2</sub> would not exceed any of the applicable NAAQS (see table 4.13.12-2). Thus, these cumulative emissions would not cause a significant cumulative impact on air quality. While the new compressor stations would contribute to a cumulative impact on air quality in the PSD areas of impact (i.e., 32 miles), as shown in the modeling analysis, this impact would not exceed the NAAQS, which were established to protect public health (including sensitive populations) and public welfare. Future projects that are considered to be major sources of air emissions would be required to conduct a similar PSD analysis.

**TABLE 4.13.12-2**

**NAAQS Full Impact Analysis for 1-hour NO<sub>2</sub> and Annual NO<sub>2</sub>  
during Operation of the MP 66 Compressor Station**

<b>Pollutant and Averaging Period</b>	<b>Year</b>	<b>Modeled NO<sub>2</sub> Concentration (µg/m<sup>3</sup>)</b>	<b>Tier 2 Adjusted Modeled NO<sub>2</sub> Concentration (µg/m<sup>3</sup>)</b>	<b>Background NO<sub>2</sub> Concentration (µg/m<sup>3</sup>) <sup>a</sup></b>	<b>Combined (Adjusted + Background) Concentration (µg/m<sup>3</sup>)</b>	<b>NAAQS (µg/m<sup>3</sup>)</b>	<b>Below NAAQS? (Yes or No)</b>
NO <sub>2</sub> 1-hour	2011–2013	154.5	123.6 <sup>b</sup>	45.7	169.3	188	Yes
NO <sub>2</sub> annual	2011–2013	22.0	16.5 <sup>c</sup>	6.4	22.9	100	Yes

Abbreviations:  
 µg/m<sup>3</sup> = micrograms per cubic meter  
 NAAQS = National Ambient Air Quality Standards

Notes:

<sup>a</sup> NO<sub>2</sub> background concentrations data were obtained from the Hamshire, Texas monitoring station.

<sup>b</sup> The Tier 2 adjusted 1-hour NO<sub>2</sub> modeled concentration was calculated by multiplying the modeled NO<sub>2</sub> concentration (Tier 1) by the default ambient ratio 0.80 (EPA, 2011b).

<sup>c</sup> The Tier 2 adjusted annual NO<sub>2</sub> modeled concentration was calculated by multiplying the modeled NO<sub>2</sub> concentration (Tier 1) by the default ambient ratio 0.75 (EPA, 2011b).

Should operation of a future project result in a significant impact on air quality, the TCEQ and the LDEQ would enforce operational limitations or require emissions controls that ensure the facility's compliance with the SIP and attainment with the NAAQS. In addition, Golden Pass would be required to comply with permit conditions during operation of the compressor stations and incorporate the required controls to limit the emissions of certain criteria pollutants, HAPs, and GHGs. Normal operation of the Calcasieu Loop would not result in measurable air quality impacts that would contribute cumulatively to the local air quality. Based on the cumulative modeling analysis and the required emissions controls, we conclude that no significant cumulative impact on air quality would result from operation of the Pipeline Expansion.

Climate Change

The cumulative impact analysis described below does not focus on a specific cumulative impact area because climate change is a global phenomenon. Climate change is the change in climate over time, whether due to natural variability or as a result of human activity, and cannot be represented by single annual events or individual anomalies. As an example, a single large flood event or particularly hot summer may not be an indication of climate change, but a series of floods or high temperatures that statistically change the average precipitation or temperature over years or decades may indicate climate change.

The Intergovernmental Panel on Climate Change (IPCC) is the leading international, multi-governmental scientific body for the assessment of climate change. The United States is a member of the IPCC and participates in the IPCC working groups to develop reports. The leading United States scientific body on climate change is the U.S. Global Change Research Program (USGCRP).

Thirteen federal departments and agencies participate in the USGCRP, which began as a presidential initiative in 1989 and was mandated by Congress in the Global Change Research Act of 1990. The IPCC and the USGCRP have recognized the following:

- Globally, GHGs have been accumulating in the atmosphere since the beginning of the industrial era (circa 1750).

- Combustion of fossil fuels (coal, petroleum, and natural gas), combined with agriculture and clearing of forests, is primarily responsible for the accumulation of GHG.
- Anthropogenic GHG emissions are the primary contributing factor to climate change.
- Impacts extend beyond atmospheric climate change alone and include changes to water resources, transportation, agriculture, ecosystems, and human health.

Both the IPCC and USGCRP have concluded that, over the last half century, climate change is being driven primarily by human activities that release heat trapping GHGs (USGCRP, 2014). In 2014, the USGCRP published the most recent National Climate Assessment for the United States, which assesses the science of climate change and its impacts across the country. The report presents information on potential impacts from climate change by resource type and by geographical region. Although climate change is a global concern, for this cumulative analysis, we will focus on the cumulative impacts of climate change in the Southeast (includes Louisiana) and Great Plains (includes Texas) regions. The USGCRP's report notes the following observations of environmental impacts that may be attributed to climate change in the Southeast and Great Plains regions of the United States

*Southeast Region:*

- “Sea level rise poses widespread and continuing threats to both natural and built environments and to the regional economy.”
- “Increasing temperatures and the associated increase in frequency, intensity, and duration of extreme heat events will affect public health, natural and built environments, energy, agriculture, and forestry.”
- “Decreased water availability, exacerbated by population growth and land-use change, will continue to increase competition for water and affect the region’s economy and unique ecosystems.”

*Great Plains Region:*

- “Rising temperatures are leading to increased demand for water and energy. In parts of the region, this will constrain development, stress natural resources, and increase competition for water among communities, agriculture, energy production, and ecological needs.”
- “Changes to crop growth cycles due to warming winters and alterations in the timing and magnitude of rainfall events have already been observed; as these trends continue, they will require new agriculture and livestock management practices.”
- “Communities that are already the most vulnerable to weather and climate extremes will be stressed even further by more frequent extreme events occurring within an already highly variable climate system.”

The magnitude of expected changes will exceed those experienced in the last century. Existing adaptation and planning efforts are inadequate to respond to these projected impacts.

The GHG emissions associated with construction and operation of the Project are identified in section 4.11.1. Those emissions would not cause any direct impacts on the environment in the general area of the Project, but may contribute incrementally to impacts in other areas. Golden Pass incorporated GHG BACT analyses as part of the air permits issued by the TCEQ (see section 4.11.1.5). Potential controls for these emissions include reducing GHG emissions, through implementation of the following BACT: (1) use

of low carbon fuels; (2) design and operational energy efficiency measures; (3) good combustion/operating practices; and (4) implementation of the 28VHP Leak Detection and Repair Program.

On December 24, 2014, the CEQ published a revised draft GHG emissions guidance memo on how NEPA analysis and documentation should address GHG emissions and the impacts of climate change. (CEQ, 2014). As recommended in this new guidance, to the extent practicable, the FERC staff has presented the GHG emissions associated with the Project and the potential impacts of GHG emissions in relation to climate change. The GHG emissions associated with construction and operation of the Project are discussed in sections 4.11.1.4 and 0, respectively. Currently, there is no standard methodology to determine how the Project's incremental contribution to GHGs would translate into physical effects on the global environment. However, the emissions would increase the atmospheric concentration of GHGs, in combination with past and future emissions from all other sources, and contribute incrementally to climate change that produces the impacts previously described. Because we cannot determine the Project's incremental physical impacts on the environment caused by climate change, we cannot determine whether the Project's contribution to cumulative impacts on climate change would be significant.

### **Noise**

The cumulative impact area for noise is considered to be within 2 miles of the Terminal Expansion and the Pipeline Expansion. Five NSAs are in the vicinity of the Terminal Expansion and MP 1 Compressor Station sites (see section 4.11.2.1). Based on the distances to the respective NSAs, sound levels from construction and operations of the Terminal Expansion and MP 1 Compressor Station are expected to remain less than the FERC noise criterion of 55 dBA  $L_{dn}$  and are not expected to result in significant impacts on the NSA.<sup>58</sup> The Sabine Pass Liquefaction Project is the only cumulative project identified where long-term noise is expected to occur in the vicinity of the Terminal Expansion and MP 1 Compressor Station sites. Noise levels during normal facility operations would adhere to the FERC regulations and less stringent local noise ordinances, and therefore are not expected to increase noise levels beyond those deemed acceptable. As a result, we believe that construction and operation of the Terminal Expansion and MP 1 Compressor Station along with the Sabine Pass Liquefaction Project would not result in a cumulative significant noise impact on the affected NSAs.

Three NSAs are in the vicinity of the MP 33 Compressor Station site, and three NSAs are in the vicinity of the MP 66 Compressor Station and Calcasieu Loop HDD sites (see section 4.11.2.1). Noise levels during construction and operation of the compressor stations and during pipeline construction using the HDD method are expected to remain lower than the FERC noise criterion of 55 dBA  $L_{dn}$  at the nearest NSAs based on noise surveys, proposed construction and operation activities, and our recommendations to minimize noise at these NSAs (see section 4.11.2). We did not identify any cumulative projects in the vicinity of the MP 33 and MP 66 Compressor Station sites or the Calcasieu Loop HDD site that would contribute to construction or operations noise impacts. Therefore, we conclude that cumulative noise impacts from construction and operation of the Pipeline Expansion would not be significant.

#### **4.13.2.12 Safety**

We considered the cumulative impact area for public safety relative to the Terminal Expansion, LNG carriers, and the Pipeline Expansion. The cumulative impact area for the Terminal Expansion includes the area adjacent to and in the vicinity of the Terminal Expansion site, and the cumulative impact area for

---

<sup>58</sup> Elevated noise levels at the nearest NSA would be expected from flaring operations at the Terminal site during worst-case planned and unplanned events. These noise levels would exceed the noise criterion of 55 dBA  $L_{dn}$ . However, because these are rare cases (once per year for planned event, or once in the facility's lifetime should a worst-case unplanned emergency flaring do happen) that would occur at a very short period of time; therefore, they are not considered in the cumulative noise assessment.

public safety related to marine vessel traffic associated with the Terminal Expansion includes the SNWW from the coast of the Gulf of Mexico to its confluence with the Gulf Intracoastal Waterway. We considered the cumulative impact area for public safety related to the Pipeline Expansion to be within about 660 yards of the pipeline centerline. The cumulative impact area for emergency services includes the area in the general vicinity of the Terminal Expansion, the authorized projects at the Sabine Pass LNG Terminal, the SNWW Deepening Project, and the Pipeline Expansion.

Golden Pass would mitigate impacts on public safety through implementation of applicable federal, state, and local rules and regulations for the Project, as described in section 4.12. Those rules and regulations would ensure that applicable design and engineering standards are implemented to protect the public and avoid or minimize the potential for accidents and failures.

As discussed in section 4.12.1, the Terminal Expansion would not pose a public risk based on the facility's design and our recommended mitigation. Because Golden Pass has not requested an increase in the number or size of LNG carriers currently evaluated for the existing terminal, the Terminal Expansion and associated LNG carrier traffic would not add to the public safety risk that was previously assessed for the existing terminal on the SNWW or the risk of an intentional attack on an LNG carrier at berth or in transit in the waterway. These risks were assessed in the EIS for the existing terminal (FERC, 2005).

As noted in section 4.12.2, the public safety risk associated with the Pipeline Expansion would be small. In addition, the Pipeline Expansion route is parallel and adjacent to the existing Golden Pass Pipeline. Although operation of the Pipeline Expansion would increase the risk of a pipeline accident, we believe that the increase in risk would be small. Consequently, we conclude that the cumulative impact on public safety related to the Pipeline Expansion would not be significant.

Emergency response time is a key aspect of public health and safety. Key emergency services are provided by the Golden Pass Import Terminal, the Sabine Pass LNG Terminal, Orange and Jefferson Counties in Texas, and Calcasieu Parish in Louisiana. Those emergency services would be expanded to include the Project, the authorized projects at the Sabine Pass LNG Terminal, and associated pipeline expansion projects. In accordance with our regulations, Golden Pass would prepare a comprehensive plan that identifies the cost-sharing mechanisms for funding these emergency response costs. With implementation of comprehensive public health and safety plans for each of the above-mentioned projects, we believe that the cumulative impact on emergency services would not be significant.





## **5.0 CONCLUSIONS AND RECOMMENDATIONS**

### **5.1 SUMMARY OF THE ENVIRONMENTAL ANALYSIS**

The conclusions and recommendations presented in this section are those of the FERC environmental staff. Our conclusions and recommendations are based on input from the COE, the Coast Guard, the EPA, the DOE, and the DOT as cooperating agencies in preparation of this EIS. However, the cooperating agencies will present their own conclusions and recommendations in their respective Records of Decision or determinations. The cooperating agencies can adopt this EIS consistent with 40 CFR 1501.3 if, after an independent review of the document, they conclude that their requirements have been satisfied. Otherwise, they may elect to conduct their own supplemental environmental analyses.

We conclude that construction and operation of the Golden Pass LNG Export Project would result in limited adverse environmental impacts. Most adverse environmental impacts would be temporary or short term during construction and operation, but long-term and permanent environmental impacts on wetlands, forests, silvicultural lands, migratory birds, and EFH would also occur as part of the Project. As part of our analysis, we developed specific mitigation measures that are practical, appropriate, and reasonable for construction and operation of the Project. We therefore are recommending that these mitigation measures be attached as conditions to any authorization issued by the Commission. We conclude that implementation of the mitigation proposed by Golden Pass and our recommended mitigation would ensure that impacts in the Project area would be avoided or minimized and would not be significant. A summary of the Project impacts and our conclusions are presented below by resource.

#### **5.1.1 Geologic Resources**

Construction and operation of the Project would not materially alter the geologic conditions of the Project area, and the Project would not affect mining of resources during construction or operation. The Pipeline Expansion would not cross any significant geologic hazards, including areas of seismic activity or subsidence. Because Golden Pass has not yet filed their geotechnical reports for the MP 33 and MP 66 Compressor Stations, we are recommending that Golden Pass file the results prior to construction. The design of the liquefaction facility is currently at the FEED level of completion. Information regarding development of the final design would need to be reviewed by the FERC staff in order to ensure that the final design addresses the requirements identified in the FEED. Therefore, we are recommending that Golden Pass file Terminal Expansion design and construction details stamped and sealed by the professional engineer of record. Blasting is not anticipated during construction of either the Terminal Expansion or the Pipeline Expansion. Based on the Golden Pass proposal, including implementation of the measures contained in FERC's Plan and Procedures, and our recommended mitigation measures, we conclude that impacts on geological resources would be adequately minimized and would not be significant, and the potential for impacts on the Project from geologic hazards also would be minimal.

#### **5.1.2 Soils**

Construction of the Project facilities would disturb soils, resulting in increased potential for erosion, compaction, mixing of topsoil, and the introduction of rock into the topsoil. Soils in the general Project area are moderately susceptible to water and wind erosion. Most soils have low to moderate revegetation potential, although some prime farmland soil with high revegetation potential would be affected by the Pipeline Expansion. The erosion potential of the soils is reduced by the generally level topography of the area.

No prime farmland soils are on the Terminal Expansion site; however, operation of the Terminal Expansion would permanently impact and convert these soils to industrial uses (i.e., aboveground facilities,

gravel, asphalt). Most impacts on prime farmland soils from construction of the Pipeline Expansion would be short term and would not affect the potential use of prime farmland for future agricultural purposes. Operation of the compressor stations and other aboveground facilities along the pipeline would permanently affect 23.4 acres of prime farmland but would not result in a significant reduction of usable prime farmland soils in the area.

Golden Pass did not encounter contaminated soil during construction of the existing terminal and the associated pipeline facilities. Golden Pass would implement the measures in its SPCC Plan if unanticipated contaminated soil is discovered during construction. The potential impacts from soil erosion would be minimized through the use of erosion control and revegetation measures described in FERC's Plan.

As a part of construction of the Terminal Expansion, Golden Pass would dredge about 455,450 yd<sup>3</sup> of material for the Supply Dock, access channel, and the associated temporary float channels. The dredged sediments would be disposed of at one of two potential DMPAs and in accordance with Golden Pass' DMMP, as authorized by its permits.

### **5.1.3 Water Resources**

The Project is underlain by the upper portion of the Coastal Lowlands Aquifer System (known as the Chicot Aquifer), an EPA-designated sole-source aquifer; however, we do not anticipate any long-term or significant impacts on the aquifer from construction or operation of the Project. Standard construction procedures could affect groundwater resources by altering overland water flow and infiltration rates. Because the recharge areas are much larger than the footprint of the Project, changes in groundwater recharge as a result of project construction are not expected to be significant. No active public water supply wells, wellhead protection areas, or springs are within 150 feet of any of the Project facilities.

Golden Pass would use municipal water or purchased raw water for hydrostatic testing and dust control at the Terminal Expansion. Because no groundwater would be used, groundwater would not be affected by hydrostatic testing.

During dredging of the Supply Dock, access channel, and the associated temporary float channels, Golden Pass would use a hydraulic cutterhead dredge or conduct a dry excavation with limited hydraulic cutterhead dredge below the exiting waterline. We conclude that the potential impacts on groundwater and surface water quality during construction and operation of the Terminal Expansion would be minimized through implementation of the measures contained in FERC's Plan and Procedures. No significant impacts on water resources would occur during construction and operation of the proposed Terminal Expansion. In addition, Golden Pass must comply with Section 404 and Section 10 Permits.

Because Golden Pass would use dredge spoil from the existing Ship Slip for wetland mitigation, Golden Pass performed a chemical analysis of sediment and water samples. The chemical analysis report has not undergone formal agency review; therefore, we are recommending that Golden Pass work with the COE and the EPA to obtain the agencies' full review of the chemistry analysis.

The Pipeline Expansion would affect one agricultural ditch and two roadside ditches. Golden Pass proposes to permanently fill two roadside ditches associated with construction of the MP 66 Compressor Station. However, because these ditches provide drainage pathways, we are recommending that Golden Pass use an appropriate waterbody crossing method and restore the ditches to their original contours following installation of the compressor station. We conclude that the potential impacts on groundwater and surface water quality during construction and operation of the Pipeline Expansion would be minimized through implementation of the measures in FERC's Plan and Procedures.

Construction of the Pipeline Expansion would require the use of municipal or raw water for hydrostatic testing of the pipeline segments. Golden Pass would follow the requirements of the LDEQ discharge permit for hydrostatic test water withdrawal and discharge that must be obtained prior to construction.

#### **5.1.4 Wetlands**

Construction of the Terminal Expansion would affect a total of about 381.4 acres of wetland, while operation would result in the permanent fill of 372.5 acres. Impacts on the 372.5 acres of jurisdictional wetlands would be offset by Golden Pass' compensatory mitigation measures, which are currently under development and detailed in its *Draft Compensatory Mitigation Plans for the Golden Pass Products LNG Export Project*. Based on its draft plans, Golden Pass would create about 721 acres of new wetlands within the J.D. Murphree WMA through the beneficial use of dredged material from the existing Ship Slip to offset permanent impacts on wetlands from the Terminal Expansion. To further minimize impacts on wetlands, Golden Pass would comply with all conditions of the Section 404 and Section 10 Permits. Because the compensatory mitigation plans have not yet been finalized, we are recommending that Golden Pass file their final plans prior to the end of the draft EIS comment period.

Golden Pass would use an HDD for a portion of pipeline installation in order to minimize impacts on wetlands in the area. Construction of the Pipeline Expansion would affect a total of about 17.0 acres of land classified as wetlands, of which 9.4 acres would be filled at the compressor station sites. The remaining affected wetlands would be allowed to revert to pre-construction conditions, including the 4.5 acres within the pipeline permanent right-of-way. The entire pipeline would be collocated with existing rights-of-way, limiting the overall impact of construction and operation.

Based on implementation of the mitigation measures outlined by Golden Pass, collocation of the Project with the existing pipeline and terminal, implementation of agency-approved compensatory mitigation, and our recommendations, we conclude that impacts on wetlands during construction and operation of the Project to the extent practicable.

#### **5.1.5 Vegetation**

No vegetative communities of special concern have been identified in the areas affected by the Project. Construction of the Terminal Expansion would affect 485.7 acres of vegetated land, of which 471.9 acres would be permanently covered with infrastructure, gravel, or other material (e.g., asphalt) for Project operations. Operation would affect 372.5 acres of wetlands (370.9 acres of PEM, 1.2 acres of PSS, and 0.4 acre of PFO), 58.7 acres of forested uplands, and 40.7 acres of open land. Although impacts on vegetation at the Terminal Expansion would be permanent, the severity of impacts would be decreased when taking into account the disturbed condition of the area, and the compensatory mitigation that Golden Pass would implement.

Impacts of the Pipeline Expansion on vegetation would range from short term to permanent, including impacts on upland forest, silvicultural land, open land, agricultural land, and wetlands. To minimize vegetation impacts (including impacts on wetlands), Golden Pass would collocate and overlap the pipeline with existing rights-of-way, comply with requirements in the Section 404 Permit, use the spill prevention measures in its SPCC, adhere to the mitigation measures provided in the FERC's Plan and Procedures, and consult the local NRCS regarding re-seeding specifications and appropriate guidelines. Golden Pass would allow most of the construction right-of-way to revert to vegetation types present prior to construction, although upland woody vegetation would not be allowed within the permanent right-of-way. About 26.5 acres of upland forest and silvicultural land (pine plantation) would be permanently affected along the pipeline route.

Access road improvements would result in a minor impact on existing vegetation. Use of a pipe storage and contractor yard would be required for the Pipeline Expansion, primarily affecting open land vegetation types, which we expect to readily return to pre-construction conditions after completion of the Project.

The Chinese tallow tree is the primary noxious species of concern along the pipeline route, and Golden Pass would control growth of this species through best-management vegetation practices and consultation with the NRCS.

We anticipate that upland impacts on herbaceous vegetation generally would be temporary or short term and would not be significant, and that impacts on forested tracts would result in long-term and limited permanent impacts.

#### **5.1.6 Wildlife and Aquatic Resources**

Construction and operation of the Terminal Expansion would remove 471.9 acres of habitat vegetation and convert the site to industrial land. This would permanently affect wildlife and wildlife habitats at the site; however, a large amount of similar or higher quality habitat exists adjacent to and near the Terminal Expansion site. In addition, because of previous development and current industrial activities within and around the Terminal Expansion site, most wildlife species in the area are acclimated to these activities. Thus, impacts related to noise, light, and human activity are expected to be minor. Golden Pass would mitigate impacts on wetland habitat by implementing the measures outlined in its final agency-approved *Compensatory Mitigation Plans*.

During construction and operation of the Terminal Expansion, temporary, minor impacts on aquatic resources would occur because of the initial and periodic dredging for the Supply Dock and existing Ship Slip area. NOAA Fisheries and the GMFMC have identified the SNWW as EFH for multiple recreational and commercial marine species. The EFH that would be affected by the Terminal Expansion includes estuarine water bottom (soft bottom sediment) and estuarine water column. To minimize impacts from dredging on EFH and EFH species, Golden Pass would use a cutterhead dredge for initial and maintenance dredging and would adhere to the measures contained in FERC's Plan and Procedures, its SPCC Plan, and existing and future COE permit requirements. Dredged material would be transported to an upland disposal area per the Golden Pass DMMP. Based on a review of species' habitats and life histories, implementation of Golden Pass' conservation measures, and implementation of the final agency-approved *Compensatory Mitigation Plans*, we conclude that adverse impacts would be minimized to the extent practicable during construction and operation of the Terminal Expansion.

Vegetation types providing wildlife habitat in land affected by the Pipeline Expansion includes upland forest, agriculture, wetlands, managed silviculture lands, and open land. The impacts of construction and operation on this habitat would range from temporary to permanent. Clearing of the temporary construction right-of-way would reduce cover, nesting, and foraging habitat for some species. However, species that use open land or early successional shrub communities may benefit from the clearing and revegetation process.

To avoid and minimize potential impacts on migratory birds, Golden Pass would implement measures developed in consultation with the FWS, the TPWD, and the LDWF, including refraining from construction during sensitive time-windows for breeding birds. Based on field survey results, the abundance of available habitat in the vicinity of the Project, and Golden Pass' commitment to implement avoidance, minimization, and mitigation measures, we conclude that adverse impacts on migratory birds would be minor.

Given that Golden Pass would collocate the pipeline with existing rights-of-way and would adhere to measures in FERC's Plan and Procedures, including revegetation requirements, we conclude that construction and operation of the Pipeline Expansion would not significantly affect local wildlife populations and do not expect additional habitat fragmentation.

No sensitive fish species, fisheries of concern, or EFH have been identified within the waterbodies along the Pipeline Expansion. With incorporation of our recommendation, Golden Pass would cross all three waterbodies (i.e., ditches) along the proposed pipeline route using open-cut methods in accordance with measures in FERC's Procedures to minimize potential impacts on aquatic resources. To provide greater protection for warmwater fisheries, Golden Pass would complete construction activities between June 1 and November 30, unless expressly permitted in writing by the appropriate state agencies. With implementation of FERC's Procedures, and adherence to agency recommendations for mitigation of impacts on aquatic resources, we conclude that these temporary and localized impacts on fish and other freshwater aquatic organisms would be minor.

### **5.1.7 Threatened, Endangered, and Other Special-status Species**

A limited amount of suitable foraging and nesting habitat is available in the Project area for federally listed, state-listed, and other special-status species—primarily associated with the SNWW. Most potential impacts would be localized and temporary during construction, or during or immediately follow maintenance dredging. Based on consultations with the FWS and Golden Pass' species-specific surveys, eight federally listed species potentially occur in the general Project area. We anticipate that construction and operation of the Project is not likely to adversely affect the piping plover, Sprague's pipit, American alligator, Atlantic hawksbill sea turtle, green sea turtle, Kemp's ridley sea turtle, leatherback sea turtle, or the loggerhead sea turtle.

In consultation with the TPWD and the LDWF, we identified 12 additional species state listed as threatened, endangered, or species of concern; however, these species would not be significantly affected by the Project with implementation of agency-approved mitigation and measures in FERC's Plan and Procedures, the SWPPP, the SPCC, and adherence to the National Bald Eagle Management Guidelines.

### **5.1.8 Land Use, Recreation, and Visual Resources**

Construction of the Terminal Expansion would be within and adjacent to the existing terminal boundaries and would affect about 918.7 acres of open land, industrial/commercial land, forested and non-forested wetlands, and open water. About 782.8 acres of the affected area would be permanently disturbed by the Project. A portion of the Terminal Expansion site is within the designated coastal zone, which is managed by the Texas RRC. We are recommending that Golden Pass file documentation of concurrence from the Texas RRC that the Project is consistent with the Texas CZMP.

Golden Pass has not requested any changes in the number or route of LNG carriers currently calling on the terminal. Although barge traffic in the SNWW would increase during construction, we anticipate that the overall impact on recreational boating and fishing would be minor.

Views of the Terminal Expansion would generally be similar to those of the adjacent existing terminal, as well as views of the Sabine Pass Export Terminal. Lighting at the terminal would be minimized to the extent practicable. Based on these considerations, we conclude that the visual impact of the Terminal Expansion would be permanent but minor and consistent with current industrial use.

Golden Pass would construct the Terminal Expansion near several recreation areas, including the Walter Umphrey State Park, J. D. Murphree WMA, Sabine Pass Battleground State Historical Park, and the Texas Point NWR. The Project would not cross any of the recreation areas or hinder use of these areas.

Golden Pass would establish satellite parking locations, and a shuttle service would transport workers to the Terminal Expansion construction area, which would mitigate congestion along SH-87 for those accessing nearby recreation areas. Golden Pass estimates from two to three barge deliveries per day to the Supply Dock, resulting in a minor increase in vessel traffic within the SNWW during construction of the Terminal Expansion; however, we do not anticipate a significant impact on recreational or commercial fishing in the vicinity of the Project.

Construction and operation of the Pipeline Expansion would include both temporary and permanent impacts on a variety of land uses: forested wetlands, scrub-shrub and emergent wetlands, upland forest and planted pine forest, open space, industrial land, and agricultural land. The entire pipeline right-of-way would overlap with or be adjacent to existing rights-of-way. Golden Pass would use public roadways and existing access roads. Most of the affected area would return to pre-construction use after the pipeline is installed. Overall, the Pipeline Expansion would permanently disturb about 55.6 acres of land.

Golden Pass would affect visual resources along the pipeline route by clearing of the right-of-way and construction of the compressor stations. Visual impacts associated with the pipeline would be greatest where the pipeline route parallels or crosses roads, trails, or prominent offsite observation points and other places where the right-of-way may be seen by passing motorists or recreationists. The presence of construction personnel and equipment would result in short-term impacts on the viewshed of those areas. Although clearing of forested land would result in minor long-term and permanent impacts on the viewshed, we conclude that the visual character would not change substantially from existing conditions at these observation points because the pipeline would be constructed within or directly adjacent to existing pipeline or utility corridors. The MP 1 Compressor Station would be constructed adjacent to the existing terminal, and any visual impacts related to construction and operation of the compressor station would be similar to those for the Terminal Expansion site. The MP 33 Compressor Station would be constructed adjacent to an existing pipeline corridor, about 0.2 mile southeast of the nearest public road. We conclude that the visual impacts would not be significant given the location of the compressor station and the existing vegetation in the area. The MP 66 Compressor Station would be constructed in a remote area with no houses, roads, or other public areas in view of the site. Given the limited access to the compressor station site, we conclude that there would be no significant impacts on visual resources.

### **5.1.9 Socioeconomics**

Construction of the Project would increase the population in Jefferson County, Texas, during the 5-year construction period of the Terminal Expansion. The peak construction workforce for the Terminal Expansion would be about 2,900 workers. Some of the workers would be from the local area; and the remaining workforce would be housed within Jefferson County, which has a large amount of transient housing available. The impact on housing would be minor to moderate. We anticipate that the impact of the combined workforce of the Terminal Expansion and the Pipeline Expansion on public services would be minor.

Construction and operation of the Project would increase local and state tax revenues from sales taxes, payroll taxes, and property taxes, and would likely increase local employment. The Pipeline Expansion would result in minor, long-term, and permanent impacts on local forestry economics, as construction would result in the loss of about 16.9 acres of pine plantation for the life of the Project.

Golden Pass would collocate the Pipeline Expansion with existing linear and facility infrastructure. The Project would not significantly affect urban or residential areas, and no disproportionately high and adverse human health or environmental effects on minority, low-income communities, or Native American tribes have been identified.

### **5.1.10 Cultural Resources**

Cultural resources surveys were conducted for the Project, including surveys of the Terminal Expansion site, the pipeline right-of-way, the compressor station sites, the contractor yard, access roads, and the new and modified pipeline interconnections. No archaeological or historic architectural resources were identified within the survey areas, and the SHPO and the FERC staffs agree that no historic properties would be affected. The review process under Section 106 of the NHPA is complete for the Project.

### **5.1.11 Air Quality and Noise**

Construction of the Project would result in temporary impacts on air quality associated with emissions from fossil-fueled construction equipment and fugitive dust. Golden Pass has not provided specific mitigation measures to control dust during construction; therefore, we are recommending that Golden Pass file a Fugitive Dust Control Plan. The Project is generally located in attainment areas; however, the delivery of equipment and facilities by marine vessels would pass through the HGB area which is classified a marginal nonattainment area for the 2008 8-hour O<sub>3</sub> standard. We conducted a General Conformity applicability determination for the estimated emissions from the marine operations through the Houston-Galveston-Brazoria area. The marine operations emissions would not exceed the general conformity determination thresholds for nitrogen oxides or volatile organic compounds (both precursors for ozone) and General Conformity would not apply to the Project. With implementation of our recommendation we would not expect construction equipment emissions to cause or significantly contribute to a violation of an applicable air quality standard.

Long-term impacts on air quality would be caused by operation of the Terminal Expansion facilities and the compressor stations. Golden Pass would minimize potential impacts on air quality associated with operation of the Terminal Expansion and MP 1 Compressor Station by adhering to applicable federal and state regulations and installing BACT to minimize emissions. The Air Quality Permit 116055 and the PSD Air Quality Permit PSDTX1386 for the Terminal Expansion and MP 1 Compressor Station was issued by the TCEQ on January 16, 2015, authorizing construction and operation of the Terminal Expansion. Golden Pass anticipates filing its minor NSR permit and Title V operating permit application with the LDEQ for the MP 66 Compressor Station in June 2017. Golden Pass anticipates filing its minor NSR permit application for the MP 33 Compressor Station in the first quarter of 2016, to ensure that the required permit would be obtained within 18 months of construction, as required by the TCEQ air permitting regulations. It is expected that compliance with the applicable state and federal air quality standards and regulations would be addressed accordingly in the corresponding permit applications and issued permits.

Construction activities and the associated noise would vary depending on the phase of construction in progress at any one time. While individuals in the immediate vicinity of construction activities could experience an increase in noise, this effect would be temporary and localized. Use of the HDD method during pipeline construction represents the greatest potential for prolonged noise impacts during construction. The noise levels at the nearest NSAs from HDD operations during construction of the Calcasieu Loop would be below our noise criterion.

Based on the distance to the NSA nearest the Terminal Expansion site, sound levels from construction would not be expected to result in adverse impacts on the NSA. Operation of the expanded terminal would generate sound levels throughout the life of the Project, but the increase in noise levels would be just above the “barely detectable” noise level increase of 3 dBA and would result in minor impacts on the nearest NSA. In addition, the noise level would be slightly above the FERC limit of an L<sub>dn</sub> of 55 dBA. Golden Pass has agreed to implement several noise mitigation measures at the Terminal Expansion and MP 1 Compressor Station sites. In addition, we are recommending that Golden Pass file a full-load noise survey no later than 60 days after each liquefaction train is placed in service. If noise levels attributable to operation of the Terminal Expansion exceed the FERC limit of an L<sub>dn</sub> of 55 dBA, Golden



Pass would reduce the terminal's noise contribution to result in a noise level that is no higher than the FERC guideline. We also are recommending that Golden Pass file a full-load noise survey no later than 60 days after placing all the Terminal Expansion facilities, including the MP 1 Compressor Station, in service. Based on the above, we conclude that operational noise from the expanded terminal would result in minor impacts on the nearest NSA.

Operation of the MP 33 and MP 66 Compressor Stations and associated maintenance activities would increase sound levels for the life of the Project. Golden Pass would implement mitigation measures to reduce noise impacts, such as installing the compressor units in an acoustically designed building. Based on our noise analysis, the predicted noise levels attributable to operation of the MP 33 and MP 66 Compressor Stations would be less than 55 dBA  $L_{dn}$  at all nearby NSAs. To ensure that noise levels would be below an  $L_{dn}$  of 55 dBA, we are recommending that Golden Pass file noise surveys during full load and, if the noise levels exceed the FERC guideline, that Golden Pass install additional noise controls to meet the guideline within 1 year of the in-service date. As a result, we conclude that the impact from noise levels during operation of these compressor stations would be minor.

### **5.1.12 Safety**

As part of the NEPA review, Commission staff must assess whether the proposed facilities would be able to operate safely and securely. As a result of our technical review of the preliminary engineering design and our recommended mitigation, we believe that the facility design proposed by Golden Pass includes acceptable layers of protection or safeguards which would reduce the risk of a potentially hazardous scenario from developing into an event that could impact the off-site public.

As a cooperating agency, DOT assisted FERC staff in evaluating whether Golden Pass' proposed design would meet the DOT siting requirements. On June 11, 2015, DOT provided a letter to the FERC staff stating that DOT had no objection to Golden Pass' methodology for determining the single accidental leakage sources for candidate design spills to be used in establishing the Part 193 siting requirements for the proposed LNG liquefaction facilities. Based on the hazardous area calculations we reviewed, we conclude that potential hazards from the siting of the facility at this location would not have a significant impact on public safety. The areas impacted by these design spills also appear to meet the DOT's exclusion zone requirements by either being within the facility property boundary or over a navigable body of water. If the facility is constructed and becomes operational, the facility would be subject to DOT's inspection and enforcement program. Final determination of whether a facility is in compliance with the requirements of 49 CFR 193 would be made by DOT staff.

In accordance with 33 CFR 127, on April 10, 2009 the Coast Guard previously provided a Letter of Recommendation regarding the suitability of the SNWW for the type and frequency of LNG vessel traffic associated with the Golden Pass LNG terminal. This Letter of Recommendation was considered by the Commission during the original siting review for the Golden Pass LNG terminal, which commenced service in 2011 as an LNG import facility. In 2013, Golden Pass notified and met with the Coast Guard regarding its intent to add liquefaction facilities to its existing facilities. Golden Pass indicated that the LNG vessel traffic associated with the terminal during export operations would remain at approximately 200 per year, which is the same level outlined in its previous WSA for the existing terminal. In a letter dated May 13, 2013, the COTP stated that, as this Project would not result in an increase in the size and/or frequency of marine traffic in the Sabine-Neches waterway, neither a revised WSA nor a Letter of Intent are needed for this Project. The COTP specified that applicable amendments would need to be made to the current Operations Manual, Emergency Manual, and Facility Security Plan to capture changes to operations associated with the proposed Project.

Golden Pass would also design, construct, operate, and maintain its pipeline and aboveground compressor station facilities to meet or exceed the DOT minimum federal safety standards in 49 CFR 192

and other applicable federal and state regulations. By designing and operating the proposed pipeline facilities in accordance with the applicable standards, the Pipeline Expansion would represent only a slight increase in risk to the nearby public.

### **5.1.13 Cumulative Impacts**

We considered the potential contributions of Project-related impacts on cumulative impacts in specific cumulative impact areas for the affected resources. As part of that assessment, we identified existing projects, projects under construction, projects that are proposed or planned, and reasonably foreseeable projects—including existing LNG terminals and future LNG liquefaction projects, currently operating and future oil and gas projects, land transportation projects, commercial developments, dredging projects, and agricultural and silvicultural activities. Our assessment considered the impacts of the proposed Project combined with the impacts of other cumulative projects on resources within all or part of the same area and timeframe. We conclude that the Project’s contribution to cumulative impacts on affected resources would not result in significant impacts.

### **5.1.14 Alternatives**

We assessed the No-Action Alternative, system alternatives, and other siting and design alternatives that could achieve the Project objectives. The range of alternatives that could achieve the Project objectives included system alternatives, alternative Terminal Expansion sites, alternative Terminal Expansion configurations and designs, alternative Pipeline Expansion aboveground facility sites, and alternative compressor station designs. Alternatives were evaluated and compared to the Project to determine whether these alternatives were environmentally preferable to the proposed Project. While the No-Action Alternative would avoid the environmental impacts identified in this EIS, adoption of this alternative would preclude meeting the Project objectives. If the Project is not approved and built, the need could potentially be met by other LNG export projects developed elsewhere in the Gulf Coast region or in other areas of the United States. Implementation of other LNG export projects likely would result in impacts similar to or greater than those of the proposed Project.

We evaluated 23 Terminal Expansion system alternatives, including five existing LNG import terminals with planned, proposed, or authorized liquefaction projects; and 18 stand-alone LNG export terminals. To meet all or part of Golden Pass’ contractual agreements, each of these projects would require substantial construction beyond what is currently planned and would not offer significant environmental advantages over the proposed Terminal Expansion. In addition, the permitting and authorization processes for constructing additional facilities and the time required for construction would substantially delay meeting the proposed timeline for the Terminal Expansion. As a result, we eliminated all potential system alternatives from further consideration.

We evaluated alternative sites for the Terminal Expansion within upland areas in a 4-mile radius of the existing terminal. Four miles is an accepted maximum length for efficient functioning of cryogenic LNG pipelines used to transport LNG from the liquefaction facilities to the LNG storage tanks. Four of the five sites identified as potential alternatives are comprised of substantial existing development or are close to existing development, including residences, schools, commercial and retail facilities, parks and roads. We concluded that these sites would be impractical, and they were eliminated from further consideration. The only upland site we identified within the 4-mile radius as a potentially viable alternative is about 0.3 mile southeast of the Terminal Expansion. Although this alternative site includes about 84 acres of upland area, the amount of available upland is not adequate to construct the liquefaction trains and associated facilities. Thus, construction at this site would disturb about 436 acres of wetlands as compared to the 381 acres of wetlands that would be affected by construction at the proposed Terminal Expansion site. This site was therefore dismissed from consideration.

We also reviewed whether alternative configurations of the Terminal Expansion, Supply Dock, and liquefaction train power supply could substantially reduce potential environmental impacts and concluded that these alternatives would not be environmentally preferable.

The entire Pipeline Expansion proposed pipeline route overlaps existing rights-of-way. As a result, many types of environmental impacts have been lessened compared to establishing new rights-of-way. We did not identify any site-specific environmental concerns that would drive the need to evaluate alternative pipeline routes, nor were any alternatives suggested during the public scoping period. We also assessed alternative sites and designs for each of the three compressor stations. We conclude that none of the alternative sites or designs considered for the compressor stations offers a significant environmental advantage over those of the proposed Project.

## 5.2 FERC STAFF'S RECOMMENDED MITIGATION

If the Commission authorizes the Project, we are recommending that the following measures be included as specific conditions in the Commission's Order. We believe that these measures would further mitigate the environmental impacts associated with construction and operation of the proposed Project. We have included several recommendations that require the applicants to provide updated information and/or documents prior to the end of the draft EIS comment period. While some of the documents may not be available until the end of the comment period, the FERC will continue to accept and consider comments on these documents, as well as those on the draft EIS, as the final EIS is prepared. We do not expect that Golden Pass' responses would materially change any of the conclusions presented in this draft EIS; instead the information requested is primarily related to ensuring that our final EIS is complete and to provide up to date information on the applicants' ongoing efforts to minimize the impacts of their Projects and comply with FERC regulations.

1. Golden Pass shall follow the construction procedures and mitigation measures described in their applications and supplements (including responses to staff data requests) and as identified in the EIS, unless modified by the Order. Golden Pass must:
  - a. request any modification to these procedures, measures, or conditions in a filing with the Secretary;
  - b. justify each modification relative to site-specific conditions;
  - c. explain how that modification provides an equal or greater level of environmental protection than the original measure; and
  - d. receive approval in writing from the Director of OEP **before using that modification.**
2. For LNG facilities, the Director of OEP has delegated authority to take all steps necessary to ensure the protection of life, health, property, and the environment during construction and operation of the project. This authority shall include:
  - a. stop-work authority and authority to cease operation; and
  - b. the design and implementation of any additional measures deemed necessary to assure continued compliance with the intent of the conditions of the Order.
3. For pipeline facilities, the Director of OEP has delegated authority to take whatever steps are necessary to ensure the protection of all environmental resources during construction and operation of the project. This authority shall allow:
  - a. the modification of conditions of the Order; and
  - b. the design and implementation of any additional measures deemed necessary (including stop-work authority) to assure continued compliance with the intent of the environmental

conditions as well as the avoidance or mitigation of adverse environmental impact resulting from construction and operation of the project.

4. **Prior to any construction**, Golden Pass shall file affirmative statements with the Secretary, certified by senior company officials, that all company personnel, EIs, and contractor personnel will be informed of the EIs' authority and have been or will be trained on the implementation of the environmental mitigation measures appropriate to their jobs **before** becoming involved with construction and restoration activities for the project.
5. The authorized facility locations shall be as shown in the EIS, as supplemented by filed alignment sheets. **As soon as they are available and before the start of construction**, Golden Pass shall file with the Secretary any revised detailed survey alignment maps/sheets at a scale not smaller than 1:6,000 with station positions for all facilities approved by the Order. All requests for modifications of environmental conditions of the Order or site-specific clearances must be written and must reference locations designated on these alignment maps/sheets.

Golden Pass' exercise of eminent domain authority granted under NGA section 7(h) in any condemnation proceedings related to the Order must be consistent with these authorized facilities and locations. Golden Pass' right of eminent domain granted under NGA section 7(h) does not authorize it to increase the size of its natural gas pipeline or facilities to accommodate future needs or to acquire a right-of-way for a pipeline to transport a commodity other than natural gas.

6. Golden Pass shall file with the Secretary detailed alignment maps/sheets and aerial photographs at a scale not smaller than 1:6,000 identifying all route realignments or facility relocations, and staging areas, pipe storage yards, new access roads, and other areas that would be used or disturbed and have not been previously identified in filings with the Secretary. Approval for each of these areas must be explicitly requested in writing. For each area, the request must include a description of the existing land use/cover type, documentation of landowner approval, whether any cultural resources or federally listed threatened or endangered species would be affected, and whether any other environmentally sensitive areas are within or abutting the area. All areas shall be clearly identified on the maps/sheets/aerial photographs. All areas must be approved in writing by the Director of OEP **before construction in or near that area**.

This requirement does not apply to extra workspace allowed by the FERC Plan and/or minor field realignments per landowner needs and requirements that do not affect other landowners or sensitive environmental areas such as wetlands.

Examples of alterations requiring approval include all route realignments and facility location changes resulting from:

- a. implementation of cultural resources mitigation measures;
  - b. implementation of endangered, threatened, or special concern species mitigation
  - c. recommendations by state regulatory authorities; and
  - d. agreements with individual landowners that affect other landowners or could affect sensitive environmental areas.
7. **Within 60 days of the acceptance of the Order and before construction begins**, Golden Pass shall file Implementation Plans with the Secretary for review and written approval by the Director of OEP. Golden Pass must file revisions to the plans as schedules change. The plans shall identify:

- a. how Golden Pass will implement the construction procedures and mitigation measures described in its application and supplements (including responses to staff data requests), identified in the EIS, and required by the Order;
  - b. how Golden Pass will incorporate these requirements into the contract bid documents, construction contracts (especially penalty clauses and specifications), and construction drawings so that the mitigation required at each site is clear to onsite construction and inspection personnel;
  - c. the number of EIs assigned per spread and/or facility, and how Golden Pass will ensure that sufficient personnel are available to implement the environmental mitigation;
  - d. company personnel, including EIs and contractors, who will receive copies of the appropriate material;
  - e. the location and dates of the environmental compliance training and instructions Golden Pass will give to all personnel involved with construction and restoration (initial and refresher training as the project progresses and personnel changes), with the opportunity for OEP staff to participate in the training session(s);
  - f. the company personnel (if known) and specific portion of Golden Pass' organizations having responsibility for compliance;
  - g. the procedures (including use of contract penalties) Golden Pass will follow if noncompliance occurs; and
  - h. for each discrete facility, a Gantt or PERT chart (or similar project scheduling diagram), and dates for:
    - i. the completion of all required surveys and reports;
    - ii the environmental compliance training of onsite personnel;
    - iii the start of construction; and
    - iv the start and completion of restoration.
8. Golden Pass shall employ a team of EIs, including at least one EI for the Project. The EIs shall be:
- a. responsible for monitoring and ensuring compliance with all mitigation measures required by the Order and other grants, permits, certificates, or other authorizing documents;
  - b. responsible for evaluating the construction contractor's implementation of the environmental mitigation measures required in the contract (see condition 7 above) and any other authorizing document;
  - c. empowered to order correction of acts that violate the environmental conditions of the Order, and any other authorizing document;
  - d. a full-time position, separate from all other activity inspectors;
  - e. responsible for documenting compliance with the environmental conditions of the Order, as well as any environmental conditions/permit requirements imposed by other federal, state, or local agencies; and
  - f. responsible for maintaining status reports.
9. Beginning with the filing of the Implementation Plans, Golden Pass shall file updated status reports with the Secretary on a **monthly** basis for the Terminal Expansion and a **weekly** basis for the Pipeline Expansion until all construction and restoration activities are complete. On

- request, these status reports will also be provided to other federal and state agencies with permitting responsibilities. Status reports shall include:
- a. an update on Golden Pass' efforts to obtain the necessary federal authorizations;
  - b. the current construction status of the Terminal Expansion and Pipeline Expansion, work planned for the following reporting period, and any schedule changes for stream crossings or work in other environmentally sensitive areas;
  - c. a listing of all problems encountered and each instance of noncompliance observed by the EIs during the reporting period (both for the conditions imposed by the Commission and any environmental conditions/permit requirements imposed by other federal, state, or local agencies);
  - d. a description of the corrective actions implemented in response to all instances of noncompliance, and their cost;
  - e. the effectiveness of all corrective actions implemented;
  - f. a description of any landowner/resident complaints that may relate to compliance with the requirements of the Order, and the measures taken to satisfy their concerns; and
  - g. copies of any correspondence received by Golden Pass from other federal, state, or local permitting agencies concerning instances of noncompliance, and Golden Pass' response.
10. **Prior to receiving written authorization from the Director of OEP to commence construction of any project facilities**, Golden Pass shall file with the Secretary documentation that it has received all applicable authorizations required under federal law (or evidence of waiver thereof).
  11. Golden Pass must receive written authorization from the Director of OEP **prior to introducing hazardous fluids into the liquefaction facilities**. Instrumentation and controls, hazard detection, hazard control, and security components/systems necessary for the safe introduction of such fluids shall be installed and functional.
  12. Golden Pass must receive written authorization from the Director of OEP **before placing into service** the Terminal Expansion and the Pipeline Expansion. Such authorization will only be granted following a determination that the facilities have been constructed in accordance with FERC approval and applicable standards, can be expected to operate safely as designed, and the rehabilitation and restoration of the right-of-way and other areas affected by the project are proceeding satisfactorily.
  13. **Within 30 days of placing the authorized facilities in service**, Golden Pass shall file an affirmative statement with the Secretary, certified by a senior company official:
    - a. that the facilities have been constructed in compliance with all applicable conditions, and that continuing activities will be consistent with all applicable conditions; or
    - b. identifying which of the conditions of the Order Golden Pass has complied with or will comply with. This statement shall also identify any areas affected by the project where compliance measures were not properly implemented, if not previously identified in filed status reports, and the reason for noncompliance.
  14. **Prior to construction**, Golden Pass shall file with the Secretary the results of geotechnical studies for the MP 33 and MP 66 Compressor Stations. (*section 4.1.3.1*)
  15. Golden Pass shall file the following information, stamped and sealed by the professional engineer-of-record in the state of Texas, with the Secretary **prior to construction**:

- a. site preparation drawings and specifications;
- b. LNG liquefaction facility structures and foundation design drawings and calculations (including prefabricated and field constructed structures);
- c. seismic specifications for procured equipment; and
- d. quality control procedures to be used for civil/structural design and construction.

In addition, Golden Pass shall file, in its *Implementation Plan*, the schedule for producing this information. (*section 4.1.6.3*)

16. **Prior to the end of the draft EIS comment period**, Golden Pass shall work with the EPA and the COE to obtain the agencies' full review of the water and sediment chemistry analysis conducted at the existing Ship Slip. Golden Pass shall file the conclusions of the reviews with the Secretary along with documentation of its consultations with these agencies. (*section 4.3.2.1*)
17. **Prior to the end of the draft EIS comment period**, Golden Pass shall file with the Secretary appropriate access road crossing methods for the two roadside ditches at the MP 66 Compressor Station. Golden Pass should restore the ditches to their original contours following installation of the compressor station. (*section 4.3.2.1*)
18. **Prior to the end of the draft EIS comment period**, Golden Pass shall file with the Secretary revised site plans and associated alignment sheets that avoid permanently impacting all wetlands at the MP 33 and MP 66 Compressor Stations or file documentation that the COE, the TCEQ, the TPWD, and the LDNR have reviewed and agreed with proposed mitigation measures. (*section 4.4.2.2*)
19. **Prior to the end of the draft EIS comment period**, Golden Pass shall file with the Secretary the final *Compensatory Wetland Mitigation Plans* for the Project. These plans shall be developed in consultation with the COE, the TCEQ, the TPWD, and the LDNR; Golden Pass shall file documentation of its consultations with these agencies. (*section 4.4.3*)
20. **Prior to construction**, Golden Pass shall file documentation of concurrence from the Texas RRC that the Project is consistent with the Texas CMP. (*section 4.8.6*)
21. **Prior to construction**, Golden Pass shall file with the Secretary, for review and approval by the Director of OEP, a *Fugitive Dust Control Plan* that specifies the precautions that Golden Pass would take to minimize fugitive dust emissions from construction activities, including additional mitigation measures recommended by the EPA to control particulate matter with an aerodynamic diameter less than or equal to 10 microns and 2.5 microns. The plan shall clearly explain how Golden Pass would implement such measures as:
  - a. watering the construction workspace and access roads;
  - b. providing measures to limit track-out onto the roads;
  - c. identifying the speed limit that Golden Pass would enforce on unsurfaced roads;
  - d. covering open-bodied haul trucks, as appropriate;
  - e. clarifying that the EI has the authority to determine if/when water or an alternative dust suppressant needs to be used for dust control; and
  - f. clarifying the individuals with the authority to stop work if the contractor does not comply with dust control measures. (*section 4.11.1.4*)

22. **Prior to the end of the draft EIS comment period**, Golden Pass shall file with the Secretary, for review and approval by the Director of OEP, a complete photochemical modeling study of the Terminal Expansion. (*section 4.11.1.5*)
23. Golden Pass shall file a full power load noise survey with the Secretary for the Terminal Expansion **no later than 60 days** after each liquefaction train is placed into service. If the noise attributable to operation of the equipment at the Terminal Expansion and MP 1 Compressor Station exceeds an  $L_{dn}$  of 55 dBA at the nearest NSA, Golden Pass shall reduce operation of the liquefaction facilities or install additional noise controls until a noise level below an  $L_{dn}$  of 55 dBA at the NSA is achieved. Golden Pass shall confirm compliance with the above requirement by filing a second noise survey with the Secretary **no later than 60 days** after it installs the additional noise controls. (*section 4.11.2.5*)
24. Golden Pass shall file a noise survey with the Secretary **no later than 60 days** after placing the entire Terminal Expansion, including the MP 1 Compressor Station, into service. If a full-load condition noise survey is not possible, Golden Pass shall provide an interim survey at the maximum possible horsepower load **within 60 days** of placing the Terminal Expansion and MP 1 Compressor Station into service and provide the full load survey **within 6 months**. If the noise attributable to operation of the equipment at the Terminal Expansion and MP 1 Compressor Station exceeds an  $L_{dn}$  of 55 dBA at the nearest NSA under interim or full horsepower load conditions, Golden Pass shall file a report on what changes are needed and shall install the additional noise controls to meet the level within 1 year of the in-service date. Golden Pass shall confirm compliance with the above requirement by filing an additional noise survey with the Secretary **no later than 60 days** after it installs the additional noise controls. (*section 4.11.2.5*)
25. Golden Pass shall file a full power load noise survey for the MP 33 and MP 66 Compressor Stations **no later than 60 days** after placing the stations into service. If a full power load condition noise survey is not possible, Golden Pass shall file an interim survey at the maximum possible power load **within 60 days** of placing the stations into service and file the full power load survey **within 6 months**. If the noise attributable to operation of all equipment at the stations under interim or full power load conditions exceeds an  $L_{dn}$  of 55 dBA at any nearby NSA, Golden Pass shall:
  - a. file a report with the Secretary, for review and written approval by the Director of OEP, on what changes are needed;
  - b. install additional noise controls to meet that level **within 1 year** of the in-service date; and
  - c. confirm compliance with this requirement by filing a second full power load noise survey with the Secretary, for review and written approval by the Director of OEP, **no later than 60 days** after Golden Pass installs the additional noise controls. (*section 4.11.2.6*)
26. **Prior to the end of the draft EIS comment period**, Golden Pass shall file with the Secretary documentation demonstrating it has filed for an Aeronautical Study under 14 CFR 77. (*section 4.12.1.3*)
27. **Prior to the end of the draft EIS comment period**, Golden Pass shall file with the Secretary:
  - a. an evaluation of the spill time needed to de-inventory the largest isolatable section around a ship loading header sizing spill;
  - b. as-built drawings for the existing Tank Area Containment Sump, depicting the overall dimensions and the height of the trough intersection;
  - c. trough system drawings defining the specific trough slopes, along with the trough sizing philosophy for the Project; and



- d. a detailed analysis of the areas that the sizing spill for the Tank Area Containment Sump would reach after exceeding that sump's usable volume underneath the trough intersection. (*section 4.12.1.5*)
28. **Prior to the end of the draft EIS comment period**, Golden Pass shall file with the Secretary an indication of whether it would limit truck deliveries to those with a maximum capacity not exceeding the impoundment capacity or whether it would accommodate larger trucks and supply a larger impoundment capacity. (*section 4.12.1.5*)
29. **Prior to the end of the draft EIS comment period**, Golden Pass shall file with the Secretary, as public information, sizing spills for the diesel area, nitrogen, oil, ammonia day tanks, thermal oxidizer/flare, compressor turbine drives, and any other sumps that could contain flammable or potentially toxic fluids. Golden Pass shall include the detailed dimensions and usable volumes for all hazardous fluid sumps that would have tank(s) within them, including for liquid nitrogen. Golden Pass shall also include a detailed explanation of how hydrocarbon condensate releases in the process area would be contained. (*section 4.12.1.5*)
30. **Prior to the end of the draft EIS comment period**, Golden Pass shall file with the Secretary detailed technical justifications to demonstrate that exposure durations would not exceed the AEGL time used in each case. (*section 4.12.1.8*)
31. **Prior to the end of the draft EIS comment period**, Golden Pass shall file with the Secretary technical justification to confirm that no significant cumulative toxic effects could occur due to the simultaneous dispersion of benzene, toluene, xylenes, hexanes, methyl mercaptan, and other toxic components in a hydrocarbon condensate release. Alternatively, Golden Pass shall include dispersion modeling using a method that can account for the maximum extent of the potential cumulative toxic impacts from a hydrocarbon condensate release. (*section 4.12.1.8*)
32. **Prior to the end of the draft EIS comment period**, Golden Pass shall file with the Secretary an analysis demonstrating that the existing LNG storage tank and the proposed new control room building are adequately designed to withstand the overpressures predicted by design spill overpressure modeling for scenario PR-361 as well as potential overpressures from scenario MR-136 in nearby congested areas. The filing shall include the results of overpressure modeling for scenario PR-361 using an appropriate model. Overpressures calculated by FLACS shall include an assessment of the uncertainty in the results. (*section 4.12.1.9*)
33. **Prior to the end of the draft EIS comment period**, Golden Pass shall file with the Secretary a revised overpressure analysis for scenario PR-361 that accounts for the geometry that would provide mitigation for the maximum distance to the 1 psi overpressure threshold. (*section 4.12.1.9*)
34. **Prior to the end of the draft EIS comment period**, Golden Pass shall file with the Secretary thermal radiation calculations for all impoundment sumps other than the ones listed in table 4.12.1-8 that could contain flammable fluids, such as sumps for oil, the thermal oxidizer/flare area, or the compressor turbine drives, as listed in the drawings filed in Response 9 in the September 25, 2015 filing. (*section 4.12.1.10*)

Recommendations 35 through 90 shall apply to the Project. Information pertaining to these specific recommendations shall be filed with the Secretary, for review and written approval by the Director of OEP, **prior to initial site preparation, prior to construction of final design, prior to commissioning, prior to introduction of hazardous fluids, or prior to commencement of service**—as indicated by each specific condition. Specific engineering, vulnerability, or detailed design information meeting the criteria specified in Order No. 683 (Docket No. RM06-24-000), including security information, shall be submitted as critical energy infrastructure information (CEII) pursuant to 18 CFR 388.112. (See Critical Energy Infrastructure Information, Order No. 683, 71 Federal Register 58,273 [October 3, 2006]), FERC Stats. &

Regs. ¶31,228 [2006].) Information pertaining to items such as offsite emergency response; procedures for public notification and evacuation; and construction and operating reporting requirements, would be subject to public disclosure. All information shall **be filed a minimum of 30 days before approval to proceed is requested.** (*section 4.12.1.3*)

35. **Prior to initial site preparation**, Golden Pass shall file an overall Project schedule, which includes the proposed stages of the commissioning plan. (*section 4.12.1.3*)
36. **Prior to initial site preparation**, Golden Pass shall provide quality assurance and quality control procedures for construction activities. (*section 4.12.1.3*)
37. **Prior to initial site preparation**, Golden Pass shall provide procedures for controlling access during construction. (*section 4.12.1.3*)
38. **Prior to initial site preparation**, Golden Pass shall file final determinations made by the FAA indicating that there would be no hazard to aircraft from the proposed LNG terminal facilities. (*section 4.12.1.3*)
39. **Prior to initial site preparation**, Golden Pass shall file a comparative analysis to support the rainout results using a computational fluid dynamics model that is able to account for the presence of the pipe rack barriers. (*section 4.12.1.7*)
40. **Prior to initial site preparation**, Golden Pass shall file additional layers of protection in the form of passive mitigation to mitigate the potential for an initiating event to develop into a BLEVE incident. (*section 4.12.1.10*)
41. **Prior to initial site preparation**, Golden Pass shall file an updated ERP to include the Golden Pass LNG Export Project facilities as well as instructions to handle onsite emergencies related to the hazardous Project fluids. (*section 4.12.1.12*)
42. **Prior to initial site preparation**, Golden Pass shall file an updated Cost-Sharing Plan identifying the mechanisms for funding all Project-specific security/emergency management costs that would be imposed on state and local agencies. This comprehensive plan shall include funding mechanisms for the capital costs associated with any necessary security/emergency management equipment and personnel base. (*section 4.12.1.12*)
43. The **final design** shall include change logs that list and explain any changes made from the FEED provided in Golden Pass' application and filings. A list of all changes with an explanation for the design alteration shall be provided and all changes shall be clearly indicated on all diagrams and drawings. (*section 4.12.1.3*)
44. The **final design** shall provide a plot plan of the final design showing all major equipment, structures, buildings, and impoundment systems. (*section 4.12.1.3*)
45. The **final design** shall provide an up-to-date complete equipment list, process and mechanical data sheets, and specifications. (*section 4.12.1.3*)
46. The **final design** shall include three-dimensional plant drawings to confirm plant layout for maintenance, access, egress, and congestion. (*section 4.12.1.3*)
47. The **final design** shall provide up-to-date Process Flow Diagrams with heat and material balances and Piping and Instrumentation Diagrams (P&ID), which include the following information:
  - a. equipment tag number, name, size, duty, capacity, and design conditions;
  - b. equipment insulation type and thickness;
  - c. storage tank pipe penetration size and nozzle schedule;

- d. valve high pressure side and internal and external vent locations;
  - e. piping with line number, piping class specification, size, and insulation type and thickness;
  - f. piping specification breaks and insulation limits;
  - g. all control and manual valves numbered;
  - h. relief valves with size and set points; and
  - i. drawing revision number and date. (*section 4.12.1.3*)
48. The **final design** shall provide P&IDs, specifications, and procedures that clearly show and specify the tie-in details required to safely connect the Golden Pass LNG Export Project to the existing Golden Pass Import Terminal. (*section 4.12.1.3*)
49. The **final design** shall include a list of all car-sealed and locked valves consistent with the P&IDs. (*section 4.12.1.3*)
50. The **final design** shall include a hazard and operability review of the completed design prior to issuing the P&IDs for construction. A copy of the review, a list of recommendations, and actions taken on the recommendations, shall be filed. (*section 4.12.1.3*)
51. The **final design** shall include the cause-and-effect matrices for the process instrumentation, fire and gas detection system, and emergency shutdown system. The cause-and-effect matrices shall include alarms and shutdown functions, details of the voting and shutdown logic, and set points. (*section 4.12.1.3*)
52. The **final design** shall include an analysis of the system for draining the LNG loading and circulating lines that clearly demonstrates that the LNG drain drums (11-MBD69001 and 12-MBD69001) are correctly sized for the surge events and that the ESD system will prevent overflow of LNG into the boil off system. (*section 4.12.1.3*)
53. The **final design** of all molecular sieve beds shall specify the blowdown conditions required to be taken into consideration when sizing the molecular sieve support system. (*section 4.12.1.3*)
54. The **final design** shall ensure that the LNG storage tank piping supports are adequately designed for the higher rated in-tank pump flow rates. (*section 4.12.1.3*)
55. The **final design** shall demonstrate that, for hazardous fluids, piping and piping nipples 2 inches or less in diameter are designed to withstand external loads, including vibrational loads in the vicinity of rotating equipment and operator live loads in areas accessible by operators. (*section 4.12.1.3*)
56. The **final design** shall include the sizing basis and capacity for the final design of the flares and/or vent stacks as well as the pressure and vacuum relief valves for major process equipment, vessels, and storage tanks. (*section 4.12.1.3*)
57. The **final design** shall include drawings and details of how process seals or isolations installed at the interface between a flammable fluid system and an electrical conduit or wiring system meet the requirements of NFPA 59A (2001). (*section 4.12.1.3*)
58. The **final design** shall provide an air gap or vent installed downstream of process seals or isolations installed at the interface between a flammable fluid system and an electrical conduit or wiring system. Each air gap shall vent to a safe location and be equipped with a leak detection device that shall continuously monitor for the presence of a flammable fluid, alarm the hazardous condition, and shut down the appropriate systems. (*section 4.12.1.3*)
59. The **final design** shall provide electrical area classification drawings. (*section 4.12.1.3*)

60. The **final design** shall specify that all emergency shutdown valves are to be equipped with open and closed position switches connected to the Distributed Control System /Safety Instrumented System. (*section 4.12.1.3*)
61. The **final design** shall include a drawing showing the location of the emergency shutdown buttons. Emergency shutdown buttons shall be easily accessible, conspicuously labeled and located in an area which would be accessible during an emergency. (*section 4.12.1.3*)
62. The **final design** shall include an updated fire protection evaluation of the proposed facilities carried out in accordance with the requirements of NFPA 59A (2001), Chapter 9.1.2 as required by 49 CFR 193. A copy of the evaluation, a list of recommendations and supporting justifications, and actions taken on the recommendations shall be filed. Specific consideration shall be given to the use of low expansion foam and other automatic fire protection measures in the condensate and hazardous fluid storage areas. (*section 4.12.1.3*)
63. The **final design** shall provide detailed calculations to confirm that the final fire water volumes would be accounted for when evaluating the capacity of the impoundment system during a spill and fire scenario. (*section 4.12.1.3*)
64. The **final design** shall provide spill containment system drawings with dimensions and slopes of curbing, trenches, and impoundments, as well as the sizing and design of the down-comer that would transfer spills from the tank top to the ground-level impoundment system. (*section 4.12.1.3*)
65. The **final design** shall provide complete drawings and a list of the hazard detection equipment. The drawings shall clearly show the location and elevation of all detection equipment. The list shall include the instrument tag number, type and location, alarm indication locations, and shutdown functions of the hazard detection equipment. (*section 4.12.1.3*)
66. The **final design** shall include a list of alarm and shutdown set points for all hazard detectors that account for the calibration gas when determining the lower flammability limit set points for methane, propane, and ethylene, and condensate. (*section 4.12.1.3*)
67. The **final design** shall include a list of alarm and shutdown set points for all hazard detectors that account for the calibration gas when determining the toxic concentration set points for condensates, ammonia, and hydrogen sulfide. (*section 4.12.1.3*)
68. The **final design** shall provide complete plan drawings and a list of the fixed and wheeled dry-chemical, hand-held fire extinguishers and other hazard control equipment. Drawings shall clearly show the location by tag number of all fixed, wheeled, and hand-held extinguishers. The list shall include the equipment tag number, type, capacity, equipment covered, discharge rate, and automatic and manual remote signals initiating discharge of the units. (*section 4.12.1.3*)
69. The **final design** shall provide facility plans and drawings that show the location of the firewater and foam systems. Drawings shall clearly show firewater and foam piping; post indicator valves; and the location, and area covered by, each monitor, hydrant, deluge system, foam system, water-mist system, and sprinkler. The drawings also shall include P&IDs of the firewater and foam system. (*section 4.12.1.3*)
70. The **final design** shall provide the procedures for pressure/leak tests which address the requirements of ASME VIII and ASME B31.3. (*section 4.12.1.3*)
71. The **final design** shall include a plan for clean-out, dry-out, purging, and tightness testing. This plan shall address the requirements of the American Gas Association's Purging Principles and Practice required by 49 CFR 193, and shall provide justification if not using an inert or non-flammable gas for clean-out, dry-out, purging, and tightness testing. (*section 4.12.1.3*)

72. **The final design** shall provide information/revisions pertaining to Golden Pass' response numbers 6, 9, 10, 11, 16, 19, 23, 24, 25, 26, 27, 28, 29, 30, 38, 40, and 43 of its May 5, 2015 filing, which indicated features to be included or considered in the final design. (*section 4.12.1.3*)
73. Golden Pass shall certify that the **final design** is consistent with the information provided to the DOT as described in the design spill determination letter dated June 11, 2015 (Accession Number 20150616-5185). In the event that any modification to the design alters the candidate design spills on which the 49 CFR 193 siting analysis was based, Golden Pass shall consult with the DOT on any actions necessary to comply with Part 193. (*section 4.12.1.6*)
74. The **final design** shall provide the design details of the pipe rack vapor barriers for the rundown line, along with a demonstration that the thermal effects and mechanical forces from a design spill release would not compromise these barriers. (*section 4.12.1.7*)
75. The **final design** shall provide a technical review of the proposed facility design that evaluates other potential locations for the proposed control room that would increase the time available to shutdown before flammable vapors would reach the building. (*section 4.12.1.7*)
76. The **final design** shall provide vapor dispersion modeling for a release of liquid nitrogen as well as the number and location of oxygen sensors to be installed in the dispersion area. (*section 4.12.1.8*)
77. The **final design** shall provide a technical review of the proposed facility design that:
  - a. identifies all combustion/ventilation air intake equipment and the distances to any possible hazardous fluid release (LNG, flammable refrigerants, flammable liquids and flammable gases); and
  - b. demonstrates that these areas are adequately covered by hazard detection devices and indicates how these devices would isolate or shut down any combustion or ventilation equipment whose continued operation could add to or sustain an emergency. (*section 4.12.1.9*)
78. The **final design** shall provide plant geometry models or drawings that verify the confinement and congestion represented in the FEED or provide revised overpressure calculations indicating that a 1 psi overpressure would not impact the public. (*section 4.12.1.9*)
79. **Prior to commissioning**, Golden Pass shall provide a detailed schedule for commissioning through equipment startup. The schedule shall include milestones for all procedures and tests to be completed: prior to introduction of hazardous fluids and during commissioning and startup. Golden Pass shall file documentation certifying that each of these milestones has been completed before authorization to commence the next phase of commissioning and startup will be issued. (*section 4.12.1.3*)
80. **Prior to commissioning**, Golden Pass shall file plans and detailed procedures for testing the integrity of onsite mechanical installation, functional tests, introduction of hazardous fluids, operational tests, and placing the equipment into service. (*section 4.12.1.3*)
81. **Prior to commissioning**, Golden Pass shall tag all equipment, instrumentation, and valves in the field, including drain valves, vent valves, main valves, and car-sealed or locked valves. (*section 4.12.1.3*)
82. **Prior to commissioning**, Golden Pass shall file a tabulated list and drawings of the proposed hand-held fire extinguishers. The list shall include the equipment tag number, extinguishing

- agent type, capacity, number, and location. The drawings shall show the extinguishing agent type, capacity, and tag number of all hand-held fire extinguishers. *(section 4.12.1.3)*
83. **Prior to commissioning**, Golden Pass shall file updates, addressing the Golden Pass LNG Export Project facilities, in the existing operation and maintenance procedures and manuals, as well as safety procedures. *(section 4.12.1.3)*
  84. **Prior to commissioning**, Golden Pass shall maintain a detailed training log to demonstrate that operating staff has completed the required training. *(section 4.12.1.3)*
  85. **Prior to introduction of hazardous fluids**, Golden Pass shall complete all pertinent tests (Factory Acceptance Tests, Site Acceptance Tests, Site Integration Tests) associated with the Distributed Control System and the Safety Instrumented System that demonstrates full functionality and operability of the system. *(section 4.12.1.3)*
  86. **Prior to introduction of hazardous fluids**, Golden Pass shall complete a firewater pump acceptance test and firewater monitor and hydrant coverage test. The actual coverage area from each monitor and hydrant shall be shown on facility plot plan(s). *(section 4.12.1.3)*
  87. **Prior to commencement of service**, Golden Pass shall update procedures for off-site contractors' responsibilities, restrictions, and limitations and for supervision of these contractors by Golden Pass staff. *(section 4.12.1.3)*
  88. **Prior to commencement of service**, Golden Pass shall label piping with fluid service and direction of flow in the field, in addition to the pipe labeling requirements of NFPA 59A (2001). *(section 4.12.1.3)*
  89. **Prior to commencement of service**, Golden Pass shall notify the FERC staff of any proposed revisions to the security plan and physical security of the facility. *(section 4.12.1.3)*
  90. **Prior to commencement of service**, progress on the construction of the proposed systems shall be reported in **monthly** reports filed with the Secretary. Details shall include a summary of activities, problems encountered, contractor non-conformance/deficiency logs, remedial actions taken, and current Project schedule. Problems of significant magnitude shall be reported to the FERC **within 24 hours**. *(section 4.12.1.3)*

In addition, recommendations 91 through 93 shall apply throughout the life of the Golden Pass facilities:

91. The facility shall be subject to regular FERC staff technical reviews and site inspections on at least an **annual basis**, or more frequently as circumstances indicate. Prior to each FERC staff technical review and site inspection, Golden Pass shall respond to a specific data request, including information relating to possible design and operating conditions that may have been imposed by other agencies or organizations. Up-to-date detailed P&IDs reflecting facility modifications and provision of other pertinent information not included in the semi-annual reports described below, including facility events that have taken place since the previously submitted semi-annual report, shall be submitted. *(section 4.12.1.3)*
92. Semi-annual operational reports shall be filed with the Secretary to identify changes in facility design and operating conditions; abnormal operating experiences; activities such as ship arrivals, quantity and composition of imported and exported LNG, liquefied and vaporized quantities, and boiloff/flash gas; and plant modifications, including future plans and progress thereof. Abnormalities shall include, but not be limited to, unloading/loading/shipping problems, potential hazardous conditions from offsite vessels, storage tank stratification or rollover, geysering, storage tank pressure excursions, cold spots on the storage tanks, storage tank vibrations or vibrations in associated cryogenic piping, storage tank settlement, significant

equipment or instrumentation malfunctions or failures, non-scheduled maintenance or repair (and reasons therefore), relative movement of storage tank inner vessels, releases of hazardous fluids, fires involving hazardous fluids or from other sources, negative pressure (vacuum) within a storage tank, and higher than predicted boiloff rates. Adverse weather conditions and the effect on the facility also shall be reported. Reports shall be submitted **within 45 days after each period ending June 30 and December 31**. In addition to the above items, a section entitled “Significant Plant Modifications Proposed for the Next 12 Months (dates)” also shall be included in the semi-annual operational reports. Such information would provide the FERC staff with early notice of anticipated future construction/maintenance at the LNG export facility. (*section 4.12.1.3*)

93. Significant non-scheduled events, including safety-related incidents (e.g., LNG, condensate, refrigerant, or natural gas releases; fires; explosions; mechanical failures; unusual over pressurization; and major injuries) and security-related incidents (e.g., attempts to enter the site or suspicious activities) shall be reported to the FERC staff. If an abnormality is of significant magnitude to threaten public or employee safety, cause significant property damage, or interrupt service, notification shall be made **immediately**, without unduly interfering with any necessary or appropriate emergency repair, alarm, or other emergency procedure. In all instances, notification shall be made to the FERC staff **within 24 hours**. This notification practice shall be incorporated into the LNG facility’s ERP. Examples of reportable incidents related to hazardous fluids include:
- a. fire;
  - b. explosion;
  - c. estimated property damage of \$50,000 or more;
  - d. death or personal injury necessitating in-patient hospitalization;
  - e. release of hazardous fluids for 5 minutes or more;
  - f. unintended movement or abnormal loading by environmental causes, such as an earthquake, landslide, or flood, that impairs the serviceability, structural integrity, or reliability of an LNG facility that contains, controls, or processes hazardous fluids;
  - g. any crack or other material defect that impairs the structural integrity or reliability of an LNG facility that contains, controls, or processes hazardous fluids;
  - h. any malfunction or operating error that causes the pressure of a pipeline or LNG facility that contains or processes hazardous fluids to rise above its maximum allowable operating pressure (or working pressure for LNG facilities) plus the buildup allowed for operation of pressure-limiting or control devices;
  - i. a leak in an LNG facility that contains or processes hazardous fluids that constitutes an emergency;
  - j. inner tank leakage, ineffective insulation, or frost heave that impairs the structural integrity of an LNG storage tank;
  - k. any safety-related condition that could lead to an imminent hazard and cause (either directly or indirectly by remedial action of the operator), for purposes other than abandonment, a 20 percent reduction in operating pressure or shutdown of operation of a pipeline in an LNG facility that contains or processes hazardous fluids;
  - l. safety-related incidents to hazardous fluids vessels occurring at or en route to and from the LNG facility; or

- m. an event that is significant in the judgment of the operator or management even though it did not meet the above criteria or the guidelines set forth in an LNG facility's incident management plan. (*section 4.12.1.3*)

In the event of an incident, the Director of OEP has delegated authority to take whatever steps are necessary to ensure operational reliability and to protect human life, health, property or the environment, including authority to direct the LNG facility to cease operations. Following the initial company notification, the FERC staff would determine the need for a separate follow-up report or follow-up in the upcoming semi-annual operational report. All company follow-up reports shall include investigation results and recommendations to minimize a reoccurrence of the incident. (*section 4.12.1.3*)





**APPENDIX A**  
**Distribution List**

## **Federal Government Agencies**

Advisory Council on Historic Preservation, Office of Federal Programs

Charlene D. Vaughn, Assistant Director for Federal Program Development

U.S. Army Corp of Engineers

Felicity Dodson

New Orleans District

James W. Little, Jr.

Planning and Policy Division

John Furry, Senior Policy Advisor

U.S. Coast Guard

Curtis E. Borland, Attorney/Advisor

Marine Safety Unit

Akaninyene Inyang, Facilities Branch Chief

Office of Environmental Management

Ed Wandelt, Commandant (CG-47)

The White House

Emmett Beliveau, Aide to Jack Lew, White House Advisor

U.S. Department of Agriculture

Farm Service Agency, Conservation and Environmental Program Division

Nell Fuller, National Environmental Compliance Manager

Farm Service Agency, Forest Services

Matthew Ponish, National Environmental Compliance Manager

Forest Service-Ecosystem Management Coordination

Joe Carbone, Assistant Director, NEPA

Natural Resources Conservation Service

Andree DuVarney, National Environmental Coordinator

U.S. Department of Commerce

National Oceanic and Atmospheric Administration

Steve Kokkinakis, Environmental Protection Specialist

Steve Leathery, NMFS National NEPA Coordinator

Heather Young, Habitat Conservation Division Fishery Biologist

U.S. Department of Defense

Office of the Assistant Secretary of the Navy (Energy, Installations and Environment)

Office of the Assistant Secretary of the Army for Civil Works

Charles Smith, Assistant for Environment, Tribal and Regulatory Affairs

Office of the Deputy Assistant Secretary of the Army (Energy and Sustainability)

Liaison, DoD Siting Clearinghouse

Office of the Deputy Assistant Secretary of the Air Force (Installations), SAF/IEI

Liaison, DoD Siting Clearinghouse

Steve Zanders

Office of Deputy Assistant Secretary of the Army, Environmental Safety and Occupational Health

Cheryl Antosh

Office of Deputy Undersecretary Defense (Installations and Environment)

Terry Bowers, Director, Environmental Security - EQ

Office of the Deputy Under Secretary of Defense (Installations and Environment), Siting  
Clearinghouse  
Chief, Mission Evaluation Branch  
Siting Clearinghouse  
Steve Sample  
USAF Basing and Units, Department of Air Force  
Jack Bush, Senior Planner/NEPA Program Manager

U.S. Department of Energy  
Natural Gas Regulatory Activities  
Bob Corbin, Deputy Assistant Secretary  
Office of Environmental Management  
Dave Huizenga, Principal Assistant Deputy Administrator  
Mark Whitney, Principal Deputy Assistant Secretary  
Office of General Counsel for Environment  
Ed LeDuc, Supervisory Attorney-Adviser (General)  
Office of Natural Gas Regulatory Activities - Office of Fossil Energy  
James J. Ward, Environmental Protection Specialist  
Kyle W. Moorman, Natural Gas Analyst  
Office of NEPA Policy and Compliance  
Carol M. Borgstrom, Director  
Office for Oil and Gas Global Security and Supply  
John Anderson, Director

U.S. Department Health and Human Services  
Edward Pfister, Environmental Program Manager  
Center for Disease Control, National Center for Environmental Health  
Sharunda Buchanan, Director, Division of Emergency and Environmental Health  
Services

U.S. Department of Homeland Security  
Customs and Border Protection  
Christopher Oh, Branch Chief

U.S. Department of Housing and Urban Development  
Environment and Energy  
Danielle Schopp, Director  
Environmental Planning Division  
James M. Potter, Community Planner

U.S. Department of Interior  
Willie R. Taylor, Director  
Bureau of Indian Affairs  
Marv Keller, Chief, Division of Environmental and Cultural Resources Management  
Bureau of Land Management  
Kerry Rogers, Senior NEPA Specialist  
Bureau of Ocean Energy Management  
James F. Bennett, Chief, Division of Environmental Assessment  
Bureau of Safety and Environmental Enforcement  
Charles B. Barbee, Chief, Environmental Enforcement Division

Fish and Wildlife Service  
Pat Carter, National Coordinator  
Chip Gimsey  
David Hoth

National Park Service  
Patrick Walsh, Chief, Environmental Planning and Compliance Branch

Natural Resources Management, Office of Environmental Policy and Compliance  
David Sire, Team Leader  
Vijai N. Rai, Team Leader

U.S. Department of Justice  
Environment and Natural Resources Division  
Beverly Li, NEPA Coordinator

U.S. Department of State  
Bureau of Oceans and International Environmental and Scientific Affairs  
Alexander Yuan, Foreign Affairs Officer

U.S. Department of Transportation  
Office of Assistant Secretary for Transportation Policy  
Camille Mittelholtz, Environmental Policy Team Coordinator  
Helen Serassio, Special Counsel

Pipeline and Hazardous Materials Safety Administration  
Christi Craddick, Commission Chairman  
Jeffrey Wiese, Associate Administrator for Pipeline Safety  
Magdy El-Sibaie, Associate Administrator for Hazardous Materials Safety  
Sherri Pappas, Senior Assistant Chief Counsel

Community Assistance/Technical Services  
Office of Pipeline Safety  
Bryn Karas, Senior Attorney  
Karen Lynch, National CATS Coordinator  
Kenneth Y. Lee, Director, Engineering and Research Division

Surface Transportation Board  
Victoria Rutson, Chief, Section of Environmental Analysis

U.S. Environmental Protection Agency  
Agatha Benjamin  
Alfred Dumaul  
Barbara Keeler  
Cliff Rader, Director, NEPA Compliance Division  
Cynthia Giles, Assistant Administrator, Office of Enforcement and Compliance Assurance  
David Gillespie  
Jeff Riley  
Jerome Blackman, Natural Gas STAR  
Kimeka Price  
Maria Okpala  
Mike Jansky  
Rob Lawrence  
Susan E Bromm, Director, Office of Federal Activities  
Tina Arnold  
Melanie Magee, Region 6

U.S. Geological Survey  
Esther Eng, Chief, Environmental Management Branch

White House Council on Environmental Quality  
Jason Bordoff, Associate Director for Energy and Climate Change  
Horst Greczmiel, Associate Director for NEPA Oversight  
Manisha Patel, Deputy General Counsel  
Christy Goldfuss, Council on Environmental Quality Advisor  
Heather Zichal, Energy Policy Advisor

**Federal Representatives**

California 48th District  
Congressman Dana Rohrabacher

California 49th District  
Congressman Darrell Issa

Kentucky 1st District  
Congressman Ed Whitfield

Louisiana 3rd District  
Congressman Charles Boustany

Maryland 5th District  
Congressman Steny Hoyer

Michigan 6th District  
Congressman Fred Upton

Missouri 7th District  
Congressman Billy Long

New York 12th District  
Congressman Carolyn Maloney

Ohio 6th District  
Congressman Bill Johnson

Ohio 13th District  
Congressman Tim Ryan

Pennsylvania 9th District  
Congressman Bill Shuster

Texas 2nd District  
Congressman Ted Poe

Texas 4th District  
Congressman John Ratcliffe

Texas 14th District  
Congressman Randy Weber

Texas 29th District  
Congressman Gene Green

Utah 1st District  
Congressman Rob Bishop

Wisconsin 3rd District  
Congressman Ron Kind

### **Federal Senators**

Energy and Natural Resources Committee Office  
Chairman Jeff Bingaman  
Senator Lisa Murkowski

Louisiana  
Senator David Vitter

New Mexico  
Senator Martin Heinrich

North Dakota  
Senator John Hoeven

Oklahoma  
Senator James Inhofe  
Senator James Lankford

Texas  
Senator John Cornyn  
Senator Ted Cruz

Wyoming  
Senator John Barrasso

### **State Agencies**

Louisiana Department of Environmental Quality  
Air Permits Division  
Dan Nguyen  
Water Permits Division  
Valerie Powe

Louisiana Department of Wildlife and Fisheries  
Louisiana Department of Wildlife and Fisheries  
Kyle Balkum, Biologist

Railroad Commission of Texas  
Bill Black, Chief of Staff  
David Porter, Chairman  
Leslie Savage, Chief Geologist  
Mary Bell, Special Assistant  
Stacie Fowler, Director of Government Affairs  
Tim Poe, Asst. Director of Administrative Compliance  
Oil and Gas Division  
Railroad Commission of Texas, Oil and Gas Division  
Lori Wrotenbery, Director

Texas Commission on Environmental Quality  
Lt. Gen. Joe Weber, Executive Director  
Erik Hendrickson  
Air Permits Division, Office of Permitting, Remediation, and Registration  
Rebecca Partee, Manager  
Intergovernmental Relations  
Mark Harmon, Director  
Water Quality Division  
Chris Linendoll, Manager  
David Galindo, Division Director

Texas General Land Office  
Anne Idsal, Deputy Commissioner

Texas Historical Commission  
Bill Martin, Lead Reviewer for Section 106 NHPA  
Archeology Division  
Amy Borgens, State Marine Archeologist  
Jeff Durst, Terrestrial Archeologist, Project Reviewer

Texas Parks and Wildlife Department  
Coastal Management Program  
Ashley Thompson  
Natural Resources  
Ross Melinchuk, Deputy Executive Director  
Wildlife Division  
Julie Wicker, Habitat Assessment Program Supervisor

### **Local Government**

Beaumont Chamber of Commerce  
Jim Rich, Executive Director

Jefferson County  
Deloris Prince, Mayor of Port Arthur  
Jeff Branick, County Judge

Sabine Neches Navigation District  
Randy Reese, General Manager

### **Native American Tribes**

Alabama-Coushatta Tribe of Texas  
Ronnie Thomas, Chairman

Caddo Nation of Oklahoma  
Brenda Edwards, Chairman

Chitimacha Tribe of Louisiana  
John Paul Darden, Chairman

Coushatta Tribe of Louisiana  
Lovelin Poncho, Chairman

Jena Band of Choctaw Indians  
B. Cheryl Smith, Principal Chief



Mississippi Band of Choctaw Indians  
Phyliss J. Anderson, Chief

The Quapaw Tribe of Indians  
John Berrey, Chairman

Tunica-Biloxi Indian Tribe  
Earl J. Barbry, Sr., Chairman

### **Media**

DeQuincy News

KYKR - Clear Channel Radio

### **Companies**

C Doornbos A and B LP

Calder Capital Group  
Christopher H. and Phelan Ohmstede

CBB Family Limited Partnership  
Helen Benckenstein Joyner

Central Yard LLC, William F. Scott 1991 TR

ConocoPhillips Company  
Ben J. Schoene, Sr. Regulatory Analyst  
Stephanie D. Jones, Sr. Commercial Specialist

Crest Natural Resources LLC  
David Grassi, R.F. President

Crown Pine Realty 4 Inc.  
Campbell Group LLC

D&J Pier LLC

Eldridge Construction Inc.

Entergy Gulf States Utilities

Enterprise Refined Products Co LLC Texoma - Orange County

FLB/CCB Family Limited Partnership, et al.  
Helen Benckenstein Joyner

Forestree GM LLC  
Hancock Forest Management

Golden Pass Products, LLC

Blaine Yamagata, Vice President and General Counsel  
Richard D. Smith, Senior Regulatory Affairs Consultant

Gulf South Pipeline

ICG

Albert M. Miller  
Charles Barrett Monday  
Charles Brigham Miller  
Charles Dufferin Wigle  
Edgar Miller, Jr.  
Elaine Elder King McCarrick  
Elaine M. Tieman  
F. Lisle Peters, Jr.  
Fitzhugh Elder III  
Jack Martin Miller  
Jane Wigle Torrey  
Johannah Peters Smith  
John G. Miller  
John Milner Paret  
Lucy Lee Miller  
Mary Elizabeth Miller Huggins  
Mary Martha Miller  
Michael Gilpin Miller  
Nancy Monday Glass  
William Arthur Miller

John & Hengerer  
Kevin Sweeney

Kemp Properties LP  
James Kemp

KUDU Limited II, Inc.

Labelle Properties Ltd.

Marlin Ventures LLC

McClelland Family LLC

MWF Madison LLC  
Molpus Woodlands Group LLC

Northern Natural Gas Company  
Property Tax Department

OCF Properties Ltd.

Orthwein Petroleum, Inc.

PBA Properties LLC et al.  
Walker Louisiana

Penton and Penton

Port Arthur LNG Holdings LLC

Rauser Farm Inc.

Rayonier Louisiana Timberlands LLC  
Tracy Arthur, c/o Rayonier

Rosedale Ventures LP

South Texas Land, LP

Tennessee Gas Pipeline Company  
Texas Eastern Transmission Corporation  
Weyerhaeuser Company

**Individuals**

A. B. Furby Estatem c/o Martha Furby Wagar  
Aaron Lavergne  
Aaron Mullins  
Abraham Abdalla  
Adam Saunders  
Al Dyar  
Aledia F. Metz  
Alma Frances Langham  
Alvin Smith  
Amanda Etheredge  
Amanda Kile  
Amy Bean  
Ann Martin Collins, Marshall & Helton Gayle Marshall  
Arebel De Torres  
Arline Miller Stanley  
Barbara B. Mayfield  
Barbara Jensen  
Barbara Smith Somerville  
Becky Bellard  
Becky Dolan  
Becky Knott  
Ben C Hebert Heirs, c/o James C. Potter Jr., Manager  
Bert Black  
Bill Sarver  
Billie Taylor  
Billy Harrison  
Billy Walter Odom and Era Jane  
Blake Hopper  
Bob Williamson  
Bobby G. Walker and Julie L. Norwood Walker

Bobby Tarter and Phyllis  
Bruce Barnard  
Bryan I. and Susan Gray  
Bui Khang Trong, Golden Marine  
Burney Baque  
Calvin Gary Walker  
Carla and Jeanette A Sanders  
Carmelia Staley  
Carol W. and Arnold Hernandez  
Chad Collins  
Charles Adkins  
Charles Barrett Monday II  
Charles Brigham Miller  
Charles P. and Elizabeth Lazenby  
Charles V. Hanson et ux.  
Charles Wigle et al.  
Charlotte Renee McClelland Guidry  
Charra M Wright  
Cheryl and Carl Snider  
Chris and Pamela Johnson  
Chrissy Pelatan  
Claude Whitaker  
Curtis Estes  
Dallbess and Johnnie M. Landry  
Daniel Edgar Perry  
Daniel Huff  
Dannie S Gaudet  
Darlene Moody  
Darrell Paul McKee  
David Crain  
David Creel  
David M. and Karen R Albright  
David Weber  
Debra and Charles Coursey  
Delores Chevis

Deloris Prince  
Don Postlethwait Estate, c/o Paula Halter  
Donald Robert Wallace III  
Donnie Courville  
Doug Mullins  
Earl and Marie S Conely  
Earl Kile  
Ed Johnson  
Edgar Miller, Jr.  
Edwin A Jr. and Peggy Roberts  
Elaine Elder King McCarrick  
Elaine Mathilda Tieman Trust, c/o ICG  
Erin Connors  
Ernest Martin Miller Testamentary Trust, et al.  
Ernest Ovie Granger  
Ervin Glenn Stanley et ux.  
Eugenia Seale Myers  
Eva Lucille Pierson Rauser Estate, Phil Rauser  
Evan and Craig S. Phillips  
Evelyn White  
Fitzhugh Elder III  
Floyd Batiste  
Floyd Johnson  
Francis M. Furnance  
Fred Tieman Crawford Currie Trust, Frederick T. Currie  
Gary Bossley  
Gary Sztaba  
George D. Thompson  
George L. Catlin Revocable Trust  
Glenda Eldridge  
Grayson Clary Estate, c/o Arthur Berry  
Greg Cormier  
Harold B Poor  
Harold G. McGuire Jr.  
Heman Patel

Henry A. Stanley et ux.  
Hon Le  
Hubert F. Hawthorne Jr. et al.  
Ira McNeil  
J W Pillsbury  
Jack H. and Sandra Ikenaga  
Jack H. and Sandra McGuire  
Jake Daughenbaugh  
James C. and Carolyn Cockran  
James D Brunson  
James Elton Stains et ux.  
James Listou  
James Madison Waldrep  
James Marcantel  
Jane Kathryn Swanson  
Jane Shea Peters  
Jean Stanton  
Jeff Branick  
Jeff Fawcett  
Jeff Hayes  
Jeff Johnson  
Jennifer Pate  
Jennings and Leann Ewing  
Jeremy Robinson  
Jerrell and Patricia Redwine  
Jerry D. Hanlon  
Jerry Frey  
Jerry J. and Donna J. Harris  
Jim Meadows  
Jimmy Dike  
Jimmy Kile  
JoAnn Special  
Joanne Brown  
Jody E. Crump  
John A. Bankston (Estate)

John Comeaux  
John Durkay  
John E. and J. Benoit  
John Gardere Miller  
John M Thurston  
John Marshall Dickerson, et al  
John Milner Paret  
John Worthington  
Jonathan Stevenson  
Joni Huepers  
Joseph Lister  
Joseph Mattaliano  
Joshua Cook  
Josie Rita Dunn, c/o Michael Stine  
Joven I. and Victor M. Fermo Jr.  
Joyce McClain, c/o Sandra Dollarhide  
Juanita Miller Wigle  
Judith Granger  
Judith Lynne Williams  
Judy S. Hennigan  
Justin McKenzie  
Karen Creel  
Karen Garrison  
Kathleen Jackson  
Katrina H. Roy Estate, c/o Robert T. Roy, Jr.  
Keestan Cole  
Keith Conley  
Kelly Rising  
Kenneth and Patsy Hasara  
Kenny Tims  
Kevin McCabe  
Kirk Blood  
Kirk Brame  
Kristina Rogers-Butler  
Krystle Eldridge-Soderholm

Lance Deshotel  
Laura Smith, James Thomas Modawell, III  
Leonard Ferguson  
Leslie Sorter  
Linda Ashworth  
Lloyd Parker, c/o David Foster  
Loran and Mary Ethelyn Bosarge  
Lorraine W. Williams Testamentary Trust, c/o ICG  
Lorri McClelland Walton  
Lucy Lee Miller Higgins  
Malcolm Wilburn  
Manh Le  
Manley Sims  
Margaret G. Stephens  
Mark and Tracey Brodeur  
Martin J. Leverett, Jr.  
Mary Ann Reid  
Mary Burden  
Mary Elizabeth Miller Huggins  
Mary Lisle Peters  
Mary Martha Miller, et al.  
Mary Wallace  
Matt Hendon  
Michael R and Jennifer D Zumwalt  
Mike Danahay  
Mike Sculley  
Morgan D. and Deven A. Michael  
Morris O. and Peggy G. Turner  
Nam and Borey Bin Khorn  
Nancy Portwood Monday Glass  
Nikki Tibbs  
Oland G. and Alice Rogers Gloria Wrights  
Olivia Saunders  
Paddy Doyle  
Pat O'Connor



Patricia Peters Ingram  
Paul and Sue Hanner Beard  
Paul Looney  
Paul W McCormick  
Paula Bothe  
Perry Henderson  
Pham Lee  
Precilla Reeves  
Randall Ray and Janice S Peters  
Randy Anderson  
Raymond Scott  
Rebecca Barker  
Richard and Bobbie Jo Sclerandi  
Richard and Donna Peterson  
Robert Hickman  
Robyn Deshotel  
Ron Arceneaux  
Ron Arrington  
Ronald and Susan Miller  
Ronald C. and Virginia Henderson  
Ronda Landry  
Ronnie D. and Maurine A. Wyble  
Rose Baque  
Rose Foster  
Russel Buss  
Russell E. and Sandra Lynn Gripp  
S Cologne  
Sam Badger  
Sandra M. Story  
Sara Bergeron  
Scott Bandy  
Scott Hall  
Scott Kruttlin  
Scott LaBurn  
Shannon Williamson

Shawn Loiacano  
Shedrick Evans  
Shelley Smith Ingram  
Sonny Stevenson  
Stephen C. Roaone  
Steve Bennett  
Steve Starks  
Steve Trahan  
Stuart N and Patti F Salter  
Terry L. and Darlene R. Jackson  
The Miller Family Trust A Testamentary Trust for Ruth Miller Williams, c/o Allen Edgar Williams  
Thomas Allen Barr  
Thomas E Natho  
Tim Porter  
Toby E Mahle  
Wade Broussard  
Wanda Richardson  
Wesley B Sonner  
William Doornbos and Opal Trust  
William Ernst  
William H. Jr. and Deborah Woolard  
William J. Merritt  
Winfred O Smith  
Wood P. Menard  
Zach Johnson

**APPENDIX B**  
**Alignment Sheets**

LAND	TRACTS	08912-0000-330-001 GULF SOUTH PIPELINE 168912-0000-440-001 WETLANDS COMPANY 168912-0000-440-002 WETLANDS COMPANY 168912-0000-440-003 GULF SOUTH PIPELINE TENNESSEE GAS PIPELINE COMPANY	08912-0000-330-001 WET SCHULSIEB COMPANY	08912-0000-340-001 WEYERHAEUSER COMPANY	08912-0000-430-001 CROWN PIPE REALTY 4 INC	08912-0000-440-001	04912-0000-330-001	04912-0000-340-001	LAND
	CROSSING METHOD	TRENCH							



ENVIRONMENTAL	WETLANDS			PEMx	Upland	PEM	Upland	PEM	Upland	PEM	Upland	PEM	Upland	PEM	Upland	PUB	Upland	PEM	Upland	PEMx	Upland	PEMx
	SOIL TYPE		Kd		Go		Kd		Go		Gy		Go		Bo		Go		Kd		Go	Kd
	WATERSHED	Lower Calcasieu											West Fork Calcasieu									



<b>WETLAND TYPES</b> PEM Palustrine Emergent Wetland PEMF Palustrine Emergent Wetland, Semipermanently Flooded PEMX Palustrine Emergent Wetland, Artificially Flooded PUB Palustrine Unconsolidated Bottom Wetland		<b>LEGEND</b> WALEPOST LOOP WALEPOST HDD ENTRYPST PIPELINE ROUTE ROAD CL PERMANENT EROSION BOUNDARY TEMPORARY WORKSPACE BOUNDARY TEMPORARY WORKSPACE COMPRESSION STATION AUXILIARY SITE ACCESS RD. (PERMANENT) ACCESS RD. (TEMPORARY) PROPERTY PARCEL WATERBODY WETLAND WATERBODY CL		<b>PROJECT INFORMATION</b> Golden Pass Products Golden Pass Pipeline DRAWN BY: JK DATE: 2014-09-23 CHECKED BY: MA PROJECT MANAGER: MA <b>CALCASIEU LOOP ALIGNMENT SHEET 1</b> <b>CALCASIEU PARISH, LOUISIANA</b> SHEET 1 OF 2 <b>GPX 1707 03-072</b> REV: 00 <b>DRAWING INFORMATION</b> PRINTED SIZE: 27" x 36" 11" x 14" SCALE: 1" = 300' 0 100 200 400 600 800 FEET	
<b>SOIL TYPES</b> GD Geyton Silt Loam GO Geyton Silt Loam, Occasionally Flooded GY Geyton Messer Silt Loam ED Kinder Messer Silt Loam		<b>NOTES</b> 1. See Appendix C in Resource Report 2 for additional information on individual wetlands (e.g. W-05B) 2. Elevation data will be provided during FEED			





**APPENDIX C**  
**Horizontal Directional Drill Monitoring and Contingency Plan**

Public Version



**Golden Pass LNG Export Project**

**Docket No. CP14-\_\_-000**

**Horizontal Directional Drill Monitoring and  
Contingency Plan**

**Final**

July 2014

## Golden Pass LNG Export Project Draft Horizontal Directional Drill Monitoring and Contingency Plan

### TABLE OF CONTENTS

1.0	INTRODUCTION .....	1
2.0	HDD PROCESS .....	3
3.0	DRILLING MUD RELEASE PREVENTION.....	4
4.0	RESPONSIBILITY OF HDD CONTRACTOR.....	5
5.0	ENVIRONMENTAL INSPECTION AND TRAINING .....	5
6.0	MONITORING FOR AN ACCIDENTAL RELEASE OF DRILLING MUD .....	5
7.0	NOTIFICATIONS.....	6
8.0	INITIAL RESPONSE TO AN ACCIDENTAL RELEASE OF DRILLING MUD .....	7
9.0	CONTAINMENT AND REMOVAL.....	8
9.1	Surface Waters .....	8
9.2	Wetlands.....	8
9.3	Uplands.....	9
10.0	ABANDONMENT.....	9



## Golden Pass LNG Export Project Horizontal Directional Drill Monitoring and Contingency Plan

### LIST OF ACRONYMS AND ABBREVIATIONS

Bcfd	Billion cubic feet per day
Calcasieu Loop	24-inch diameter pipeline loop
EI	Environmental Inspector
FERC	Federal Energy Regulatory Commission
Golden Pass	Collectively, GPP and GPPL
GPLNG	Golden Pass LNG Terminal LLC
GPLNG Terminal	Existing GPLNG LNG import terminal
GPP	Golden Pass Products LLC
GPPL	Golden Pass Pipeline LLC
GP Pipeline	Existing GPPL pipeline system
GPX Pipeline	Golden Pass Export Pipeline
GPX Project	Golden Pass LNG Export Project
GPX Terminal	Golden Pass LNG Export Terminal
HDD	Horizontal Directional Drill
HDDMCP	HDD Monitoring and Contingency Plan
hp	Horsepower
LNG	Liquefied natural gas
MP	Mile Post
NGA	Natural Gas Act
NGPL	Natural Gas Pipeline Company of America
SNWW	Sabine-Neches Waterway
TETCO	Texas Eastern Transmission, LP
Tennessee Gas	Tennessee Gas Pipeline Company, L.L.C.
Texoma	Texoma Pipeline Company
Transco	Transcontinental Gas Pipe Line Company, LLC

## Golden Pass LNG Export Project Draft Horizontal Directional Drill Monitoring and Contingency Plan

### 1.0 INTRODUCTION

Golden Pass Products LLC (“GPP”) and Golden Pass Pipeline LLC (“GPPL”, collectively with GPP, referred to as “Golden Pass”) are requesting authorization from the Federal Energy Regulatory Commission (“FERC”) pursuant to Sections 3 and 7 of the Natural Gas Act (“NGA”), respectively, to site, construct and operate a liquefied natural gas (“LNG”) export project (“GPX Project”) along with associated new compression and loop pipeline facilities. The GPX Project consists of the following:

1. Liquefaction facilities (“GPX Terminal”) to be constructed contiguous to and integrated with Golden Pass LNG Terminal LLC’s (“GPLNG”) existing import terminal site (“GPLNG Terminal”) located onshore along the Sabine-Neches Waterway (“SNWW”) in Jefferson County, Texas; and
2. Modification of GPPL’s existing pipeline system (“GP Pipeline”) by construction of approximately three (3) miles of new 24-inch pipeline loop, three (3) new compressor stations, and necessary modifications to interconnections for bi-directional service (collectively, the “GPX Pipeline”). The GPX Pipeline includes the following initiatives:
  - Installation of approximately three (3) miles of new 24-inch diameter pipeline loop (“Calcasieu Loop”) between surface facilities operated by Texas Eastern Transmission LP (“TETCO”) and Tennessee Gas Pipeline Company, L.L.C. (“Tennessee Gas”) in Calcasieu Parish, Louisiana. The Calcasieu Loop will be installed parallel and adjacent to the GP Pipeline mainline between Mile Post (“MP”) 63 and MP 66 in an area largely managed for timber production.
  - Installation of three (3) compressor stations (approximately 120,000 site-rated brake horsepower [“hp”] total) to facilitate the receipt and delivery of a maximum of 2.7 billion cubic feet per day (“Bcfd”) of natural gas supply to the proposed GPX Terminal. These compressors will be installed at the following locations:
    - The MP 1 Compressor Station will be located near the interconnection with the Natural Gas Pipeline Company of America’s (“NGPL”) pipeline. The compressor station will be sited in an open land area previously used for oil and gas extraction adjacent to the existing GP Pipeline and situated in the southwest corner of the GPLNG Terminal site in Jefferson County, Texas.
    - The MP 33 Compressor Station will be located near the interconnection with the Texoma Pipeline Company’s (“Texoma”) pipeline. The MP 33 Compressor Station will be sited in an upland forested area of Orange County, Texas.
    - The MP 66 Compressor Station will be located near the interconnection with the TETCO’s pipeline. The compressor station will be sited in a recently cleared area managed for silviculture (tree farming) in Calcasieu Parish, Louisiana.
  - Aboveground modifications and upgrades to existing interconnections will be required for bi-directional flow capabilities and increased throughput. Existing interconnections to be modified and upgraded are as follows:

- NGPL interconnect (near MP 1), Jefferson County, Texas;
- Texoma interconnect (near MP 33), Orange County, Texas;
- Tennessee Gas interconnect (near MP 63), Calcasieu Parish, Louisiana;
- TETCO interconnect (near MP 66), Calcasieu Parish, Louisiana; and
- Transcontinental Gas Pipe Line Company, LLC (“Transco”) interconnect (near MP 68), Calcasieu Parish, Louisiana.

The GPX Project will provide shippers the ability to deliver natural gas from domestic sources to the GPX Terminal via the GPX Pipeline. The GPX Terminal will convert natural gas to LNG, which will be stored and exported using GPLNG Terminal facilities. The GPX Project facilities will be constructed and operated contiguous to and integrated with the GPLNG Terminal and GP Pipeline.<sup>1</sup> Golden Pass will be designed to optimize the existing import terminal and pipeline infrastructure. Through the GPX Project, Golden Pass and GPLNG will offer both import and export services (not simultaneously) for LNG from one (1) set of facilities, strategically located to access the Gulf Coast waters for further delivery to market.

The proposed GPX Project design will use existing import terminal and pipeline facilities to the maximum extent possible, locating new facilities adjacent to existing facilities, connecting with third party pipelines to optimize compression and thereby minimizing the footprint of the new facilities. The GPX Project will be constructed and operated in a manner that minimizes any potential adverse effects to the environment, local residents, and communities.

Golden Pass is proposing to install a 24-inch pipeline loop from MP 1.6 to MP 2.6 (corresponding to MP 65.0 to 66.0 of the GP pipeline) adjacent to the existing GP Pipeline in Calcasieu Parish, Louisiana using the Horizontal Directional Drill (“HDD”) method. Golden Pass used this same pipeline construction method across these areas for the GP Pipeline which was placed into service in 2011.<sup>1</sup> An HDD, or bore, is a process that allows for trenchless construction across an area. With this method, a borehole is drilled under the area and a prefabricated segment of pipe is installed through the borehole, thereby avoiding direct disturbance to the surface of the right-of-way and the area traversed. HDDs are most commonly used to cross underneath sensitive or difficult to construct areas such as areas with slope stability issues, roads, wetlands and waterbodies. HDDs provide a number of advantages over typical pipeline construction and installation methods, such as avoidance of surface disturbance, riparian tree clearing, and in-stream construction. If an HDD crossing is successful, there are little to no adverse effects on the area crossed.

The primary environmental risk associated with the HDD crossing method is associated with the potential for inadvertent release of drilling mud. An accidental release is a condition in which drilling mud is released through cracks in the soil and migrates toward the surface. Drilling mud consists mainly of a bentonite clay-water mixture, which is not considered to be hazardous or toxic. Although drilling mud consists of nontoxic materials, the release of drilling mud in large quantities would cause turbidity, adversely affecting surface water quality and sensitive resources.

The purpose of this HDD Monitoring and Contingency (“HDDMC”) Plan is to minimize the potential for

---

<sup>1</sup> See FERC Docket No. CP04-386-000 for the GPLNG Terminal facilities and Docket Nos. CP04-400-000, CP04-401-000 and CP04-402-000 for the GP Pipeline facilities. *Golden Pass LNG Terminal LP and Golden Pass Pipeline LP*, 112 FERC ¶ 61,041 (2005), *amended*, *Golden Pass Pipeline LP*, 117 FERC ¶ 61,015, *further amended*, 117 FERC ¶ 61,332 (2006), *further amended*, 134 FERC ¶ 61,037 (2011).

an accidental release of drilling mud associated with HDD activities and establish measures that will be taken to mitigate the inadvertent release during HDD operations associated with the GPX Project. The objective of this HDD contingency plan is to:

1. Minimize the potential for an accidental release of drilling mud associated with HDD activities;
2. Provide for the timely detection of an accidental release of drilling mud;
3. Protect areas that are considered environmentally sensitive (e.g., streams, wetlands, other biological resources, cultural resources);
4. Ensure an organized, timely and “minimum-impact” response in the event an accidental release of drilling mud occur; and
5. Ensure that all appropriate notifications are made.

Measures to be deployed as part of the contingency plan include:

1. Site inspection;
2. Proper training of the contractor and construction personnel;
3. Development of response procedures;
4. Provision of containment materials; and
5. Implementation of appropriate clean-up procedures.

## 2.0 HDD PROCESS

The HDD method is a technically advanced process involving specialized equipment and skilled operators. This method uses drilling mud to remove the cuttings from the borehole, stabilize the borehole and act as a lubricant and coolant to the drill. Drilling mud consists primarily of water and bentonite. Bentonite is a naturally occurring clay made up of 1-5 percent active clays, 0-40 percent inert solids and the remainder being water. Bentonite is a naturally occurring, nontoxic, inert substance that meets *NSF/ANSI 60 NSF Drinking Water Additives Standards* and is frequently used for drilling potable water wells. Drilling mud is not a hazardous material; however, an inadvertent release will require mitigation measures to minimize effects to a wetland or other sensitive area.

The first step of conducting the HDD will be to drill a small-diameter pilot hole from one (1) side of the crossing (entry side) to the other (exit side). Drilling will be achieved using a powered drill bit. The drilling mud will be pumped into the drill hole through the drill pipe during the drilling process. The pressure of the drilling mud will:

1. Transmit hydraulic power through the drill bit;
2. Transport cuttings to the surface;
3. Lubricate the drill bit; and
4. Stabilize the drill hole.

Water, the main ingredient of drilling mud, will be obtained from a nearby waterbody during drilling or will be trucked in from another source.

Small pits will be dug at, or near, the entry and exit holes to temporarily store the drilling mud and

cuttings. During an HDD, the drilling mud is prepared in a mixing tank using new, recycled and cleaned drilling muds. The drilling mud is pumped at rates of 200 to 1,000 gallons per minute through the center of the drill pipe to the cutters. Return flow is through the annulus created between the wall of the bore and the drill pipe. Cuttings are returned to the entry pit. In the entry pit, the mud is pumped to mud processing equipment. Typically, shaker screens, desanders, desilters and centrifuges remove increasingly finer cuttings from the drilling mud. The cleaned mud is recycled to the mixing tank and pumps for reuse in the borehole.

As drilling of the pilot hole progresses, segments of drill pipe will be inserted into the pilot hole to extend the length of the drill. The drill bit will be steered and monitored throughout the process to maintain the designated path of the pilot hole. To assist in steering, a sensor grid may be established on the surface on both the entry and exit sides of the HDD. The sensor grid will be fabricated by installing several stakes along and above the drill path and wrapping with an insulated coil wire. The coil wire will be then energized with a portable generator, which creates a magnetic field to help track the drill bit path.

Once the pilot hole is complete, the sensor grid will be removed and the hole will be enlarged to accept the pipeline. To enlarge the pilot hole, a larger reaming tool will be attached to the end of the drill pipe on the exit side of the hole. The reamer will then be drawn back through the pilot hole to the drill rig (entry side). Drill pipe sections will be added to the rear of the reamer as it progresses toward the rig, thereby allowing a string of drill pipe to remain in the hole at all times. Contractor shall determine the number of reaming passes and the tool diameter for each pass. A minimum of one swab (cleaning) pass shall be completed prior to initiating the pullback process. After the initial swab pass has been completed, the contractor shall assess the bore hole to determine if additional swabbing passes shall be made or if the bore hole is sufficiently prepared for pipe pullback. The final hole will be approximately 1.3 - 1.5 times larger than the pipeline to be installed.

The pipeline segment to be installed in the HDD bore will be fabricated into one (1) section on the right-of-way on the exit side of the crossing. The pipe segment will be radiographically inspected and/or hydrostatically tested prior to installation. After the hole is completed, the pipeline segment will be attached to the drill pipe on the exit side of the hole and pulled back through the drill hole toward the drill rig.

Once the pipeline is installed, excess drilling mud will be collected and incorporated into the soil in an upland area or disposed of at an appropriate facility. If water will be left over from the drilling process, it will be discharged into a well-vegetated upland area or into an energy dissipation/sediment filtration device, such as a geotextile filter bag or straw bale dewatering structure at the site.

### **3.0 DRILLING MUD RELEASE PREVENTION**

Prevention of drilling mud release is a major design consideration when determining the profile of a HDD crossing. Some of the driving factors in selecting the pipeline crossing profile are the type of subsurface material and the depth of cover material. Cohesive soils, such as clays, dense sands and competent rock are considered ideal materials for HDD. The second factor to be considered in developing a profile is adequate overburden material. Generally, a minimum depth of cover of 25 feet in competent soils should be maintained to provide a margin of safety against drilling mud seepage.

As the drill and hole opening assembly enters the ground and nears the ground surface on the other side of the wetland, it passes through the area that presents some potential for drilling mud release. Because prevention is the most effective contingency plan, drill holes will be designed to reduce the

potential for release of material in these areas. In the event of an accidental release of drilling mud, subsequent containment of the drilling mud would be managed as described in this Plan. Containment dikes in the form of berms, silt fence and hay bales are used to contain any seepage and minimize migration of the drilling mud from the work area.

The geometry of the pipeline profile can also affect the potential for drilling mud release. Profiles that require the pipe to make compound or excessively tight radii create downhole pressures that increase the potential for an accidental release of drilling mud. The profiles for the GPX Pipeline HDD crossing will minimize this potential, with very smooth and gradual vertical curves. In addition, horizontal curves will be eliminated from the HDD profile. Therefore, the potential for pressure buildup caused by pipeline geometry will be minimized.

Lastly, a successful HDD can be accomplished in the conservative design of the drill profile by examination of industry experience history, geotechnical studies prior to final design and performance during pilot hole drilling operation. A geotechnical evaluation and feasibility study of the proposed HDD site was conducted in 2004 for the existing GP Pipeline that concluded that a 36-inch pipeline HDD would be successful. Based on recent experience in this area, it is known that the soils in the area are relatively uniform, subsurface cracks or bedrock is not anticipated.

Prior to the proposed HDD crossing for the GPX Project, Golden Pass will conduct an updated geotechnical investigation to determine the exact characteristics of the soils through which the pipeline will be installed. The geotechnical investigation will identify the preferred strata in which to locate the drill to ensure the integrity of the borehole and successful completion of the installation of the proposed pipeline. The risk of potential failure of the HDD will be greatly reduced with the use of:

1. The geotechnical information;
2. Detailed, planned engineering; and
3. The contingency measures outlined in this plan.

#### **4.0 RESPONSIBILITY OF HDD CONTRACTOR**

The HDD Contractor is responsible for execution of the HDD operation, including actions for detecting and controlling drilling mud seepage. GPPL would closely supervise the progress and actions of the HDD Contractor through the use of on-site inspection teams.

#### **5.0 ENVIRONMENTAL INSPECTION AND TRAINING**

Prior to the start of construction, Golden Pass' Environmental Inspector ("EI") will conduct a training session with all key contractor, drilling and inspection personnel. All personnel working at the HDD site will be thoroughly trained in the applicable accidental release contingency plan items. In addition, the EI will ensure that the contractor has proper equipment and materials available on-site at all times, or access to them in a timely manner, and that the necessary procedures are followed. Tailgate meetings will ensure ongoing effective communications and awareness measures regarding prevention, mitigation and response associated with a potential accidental release of drilling mud.

#### **6.0 MONITORING FOR AN ACCIDENTAL RELEASE OF DRILLING MUD**

The Contractor will monitor operations during HDD activities, with oversight provided by Golden Pass' Construction Inspector and/or Environmental Inspector. Monitoring activities during drilling operations will include:



1. Pump Pressure – The drilling mud pump discharge pressure will be continuously monitored and recorded on a field data log prior to each drill pipe joint connection. Significant changes or fluctuations in pressure may indicate the possibility of an accidental release, requiring immediate response;
2. Circulation Rate – The flow rate of drilling mud circulation and the volume of returns will be continuously monitored and recorded prior to each drill pipe connection or change in return rate;
3. Ground Surface Inspection – The ground surface will be visually inspected along the progress of the HDD for indications of escaping drilling mud. Where possible, without trespassing outside the approved workspace or entering wetland areas, the inspection should cover a corridor of approved width, centered on the drill. Inspections shall be made relative to the rate of advance of the drill head, but an inspection pass should be made at least once every hour while pumping drilling mud. Any indications of an accidental release shall be reported immediately. If operating parameters (i.e., fluctuations in mud pressure or returns) indicate the possibility of an accidental release, the surface inspection shall become continuous (daylight only) until the location of the suspected accidental release is found, the drill is completed or measures to remedy the release using additives or other operational adjustments have been successful. Daylight continuous monitoring will supplement the monitoring of operating parameters. Reasonable efforts will be made to locate the point of release, if possible, in order to assess environmental damage, if any;
4. Surface Water Inspection – Wetlands will be visually inspected along the progress of the HDD, for turbidity plumes that might indicate an accidental release is occurring. Inspection passes should be made at least once every hour while pumping. Any indications of an accidental release shall be reported immediately. If operating parameters indicate the possibility of an accidental release under water, the water inspection shall become continuous (daylight only) until the location of the suspected accidental release is found, the drill is completed, or measures to remedy the accidental release using additives or other operations adjustments have been successful. Inspection shall be made by foot, or from an elevated position on uplands with an unobstructed line-of-sight to the wetland; and
5. Special Safety Considerations – Monitoring in wetlands at night, or in a fog, will require special safety precautions and equipment considerations, including potable lights of sufficient power to effectively monitor the area. No continuous nighttime monitored is planned. Monitoring in wetlands will be discontinued whenever conditions render the activity unsafe.

## 7.0 NOTIFICATIONS

In the event of an HDD drilling mud release to wetlands, or other sensitive areas, Golden Pass' Environmental Project Manager will contact State and Federal agencies (see Table 7.1-1). All appropriate agencies will be notified of the accidental release within 24 hours. The following information will be provided to each agency:

1. Time of release;
2. Location of release;
3. Quantity and type of material released and amount of recovered materials;
4. Containment and cleanup measures; and
5. Location of sensitive areas near the release.

Table 7.1-1 Golden Pass Notification Contacts		
Agency/Company	Name	Contact Number
Golden Pass (Primary Contact)	Mark Burley	Office: (832) 624-3852 Cell Phone: (832) 776-3650
Golden Pass (Alternative Contact)	Bryan Trimm	Office: (832) 624-3421 Cell Phone: (281) 381-3743
US. Army Corps of Engineers, New Orleans District	James Little Jr.	(225) 342-3099
U.S. Fish and Wildlife Service, Lafayette Ecological Services Field Office	Joshua Marceaux	(337) 291-3110
Louisiana Department of Wildlife and Fisheries	Kyle Balkum	(225) 765-2819

## 8.0 INITIAL RESPONSE TO AN ACCIDENTAL RELEASE OF DRILLING MUD

The initial response to a potential accidental release is described below.

1. Upon first indication of a potential accidental release, the drilling mud circulating pressure will be reduced, the rotation of the drill string will continue and the drill head will continue to advance in an attempt to stop or substantially reduce the release rate;
2. If the accidental release is initially or subsequently confirmed by an observed release of mud to the surface or an observed turbidity plume in water, an attempt to advance the drill head past the known point of the release will be made and regulatory agencies administering the land and drilling operation notified;
3. Concurrently, pre-approved additives may be injected in concentrations recommended by the manufacturer and as calculated onsite, into the drilling mud mixture as an additional attempt to control the release;
4. If the release of drilling mud continues unabated at a rate that threatens to expand, at a rate deemed excessive by on-site personal and appropriate agencies or completion of the drill is in jeopardy due to failure to remove cuttings from the borehole, advancement of the drill will be temporarily suspended;
5. The drill string may continue rotation in the borehole and continued circulation of drilling mud may occur at a pressure that does not result in continued mud release, in order to keep the borehole open;
6. If the accidental release is to wetlands, the analysis for containment and recovery described in Section 9.2 below will be conducted, before continuing to advance the drill;
7. If the accidental release is to uplands, the drill may continue to advance, provided the released muds are contained and removed (as described in Section 9.3 below), and after confirmation that cuttings are being returned at a sufficient rate to ensure successful completion of the



- borehole. Adjustments shall be made to the drilling mud properties to plug the release point or reduce the volume of mud being released;
8. The drill may also continue advancement if the release is to open water, the release does not obstruct a navigation channel, directly affect sensitive resources or accumulate in wetlands, and after confirmation that cuttings are being returned at a sufficient rate to ensure successful completion of the borehole. Adjustments will be made to the drilling mud properties to plug the release area or reduce the volume of mud being released. If, however, the resulting turbidity plume is deemed to be excessive, drilling may be temporarily suspended until necessary corrective measures are successfully implemented; and
  9. All parameters being tracked at the time of accidental release will be recorded, including:
    - Drilling mud circulating pressure
    - Drilling mud mixture composition
    - Drilling mud viscosity
    - Location and depth of the drill head
    - Location of the release
    - Rate of drill advance
    - Time of day
  10. The HDD Driller shall keep a running log of all activities associated with the attempts to control the accidental release.

## **9.0 CONTAINMENT AND REMOVAL**

Containment and removal of a drilling mud release to the surface will be performed where practical and where there will be a net benefit in the reduction of total environmental effects.

### **9.1 Surface Waters**

Containment and removal of drilling muds released to surface waters as a result of an accidental release is generally impractical and ineffective because of dilution in the water column, and dispersion due to currents.

### **9.2 Wetlands**

Containment and removal of released drilling mud from an accidental release to wetlands will be performed when there is a net benefit in the reduction of adverse effects, as determined by the following actions:

1. Upon confirmation of an accidental release in a wetland, the area directly affected by the released drilling mud will be measured. The area affected may be estimated from a distance, if access to the affected area from measurement would result in additional unacceptable negative effects.

2. The type of effects as a result of released mud will be characterized by qualified individual, (i.e. temporary, permanent, vegetation only, change in surface hydrology, etc.). Concurrence from the regulatory agency representative will be obtained.
3. The additional area, if any, likely to be affected if the drilling was to proceed will be estimated if the drilling muds were not contained and removed.
4. An estimate and characterization of the additional effects to wetlands likely to occur as a result of accessing the affected area for containment and removal of the drilling mud will be conducted.
5. The reduction in effects that might be achieved if the released mud were removed will be estimated.
6. The total actual effects, plus the estimated effects from continuation of an uncontained release, will be compared to the total actual effects, plus the estimated effects from accessing the area for containment and removal, less the estimated reduction in adverse effects as a result of recovery of the drilling mud. When making this comparison, some consideration and judgment should be given to the types of effects, and value of the resources affected, if dissimilar. The action resulting in the least total adverse effects will generally be selected, unless there are mitigating circumstances, or as otherwise instructed by the regulatory agency representative, if present.
7. If the decision is to forgo containment and proceed with the drill, continued observation of the location of the accidental release will occur. If the effects continue to increase, the comparison described in the bullet above will be periodically repeated, until such time as containment and removal are justified, or the drill is complete.

### **9.3 Uplands**

In upland areas, the most commonly utilized system for containment of surface releases of bentonite would typically be to incorporate a perimeter earthen berm or hay bales. Where this system of containment cannot be employed, containment procedures will be directed by the Environmental Inspector to minimize adverse effects.

### **10.0 ABANDONMENT**

A borehole will need to be abandoned if an accidental release cannot be avoided, or if an accidental release has occurred that cannot be controlled. The borehole will be completely abandoned and a new location determined. Any borehole abandonment locations will be documented and shown on any as-built documents.

The following steps will be implemented during abandonment of the borehole:

1. Determine the new location for the HDD crossing.
2. Insert casing, as necessary to remove the pilot string.
3. Pump a thick grout plug into the borehole to securely seal the abandoned borehole.

**APPENDIX D**  
**Unanticipated Discovery Plan**



## **PROTOCOLS FOR UNANTICIPATED DISCOVERY OF CULTURAL RESOURCES, BURIALS AND/OR HUMAN REMAINS**

**November 2013**

### **1.0 INTRODUCTION**

The purpose of the following protocols is to provide for the conscientious identification, evaluation, treatment, and protection of cultural resources,<sup>1</sup> burials and/or human remains that may be encountered during construction of the Golden Pass Liquefied Natural Gas (LNG) Export Project, and corollary modifications to the existing Golden Pass Pipeline system (globally known as the GPX Project).

The document includes the protocols to be employed throughout the subsurface construction phases of the GPX Project, including procedures to be followed during discovery situations and agency reporting requirements.

Any discussion, summary, or paraphrasing of the protocols presented in this document is intended as general guidance and as an aid to the user in understanding the protocols and their implementation.

### **2.0 PROTOCOLS AND PROCEDURES**

This section of the document describes the protocols and procedures to be implemented in the event previously unknown cultural deposits, unmarked burials, or human remains are encountered during project construction.

#### **2.1 Workforce Education**

It is possible that with the initiation of ground disturbing activities (e.g., trenching, grading), previously unknown cultural resources may be exposed. It is thus imperative that the contractor(s) and their employees involved with ground disturbing activities be instructed to recognize buried cultural resources. Prior to the commencement of construction activities, the contractor(s), subcontractor(s), and employees directly involved with ground disturbing activities shall understand the following protocols and procedures.

---

<sup>1</sup> For the purpose of this document the term “cultural resource” is defined as “any prehistoric or historic district, site, building, structure, or object included in, or eligible for inclusion on, the National Register of Historic Places, including artifacts, records, and material remains related to such a property or resource...” (36 CFR § 800.16).

## 2.2 Discovery of Cultural Resources

Various circumstances may lead to the unanticipated discovery of cultural resources within the GPX Project area. These may include objects or sites discovered by contractors in the course of their work activities.

A cultural resource discovery could consist of, for example:

- an area of charcoal or charcoal-stained soil;
- a circular or oblong stain in the soil;
- artifacts such as an arrowhead, stone tool, or stone chips, ceramic sherds, burned clay, or ground stone;
- a cluster of animal bones or burned rocks in association with stone tools or chips; and/or aligned stones;
- shell deposits or scattered shell on the ground surface;
- a scatter of bricks or brick piers; or
- historic artifacts including but not limited to glass, square headed nails, stoneware ceramic shards, or pieces of metal or metal fragments.

When a potential new discovery is brought to the attention of the contractor(s), the contractor(s) will stop all work in the area of the find until it has been properly managed and the Environmental Inspector (EI) is notified. Following are the procedures to be followed by the contractor(s) and their subcontractor(s) when the discovery of a potential cultural resource occurs:

- (a) the EI must be notified immediately of the contractor(s) suspected find(s);
- (b) all work will cease immediately within 100 feet of the discovery and the area will be properly fenced and protected until evaluation by a qualified archaeologist;
- (c) The Golden Pass Products (GPP) Environmental Project Manager will be notified immediately after notification to the EI. The Environmental Project Manager will provide notice to a qualified archaeologist to assess the site.
- (d) a qualified professional archaeologist<sup>2</sup> shall be retained to evaluate the potential significance of the find and, if necessary, to implement mitigation

---

<sup>2</sup> Qualified professional archaeologist is defined as those that meet the Secretary of Interior's professional qualification standards as specified in Section 112(a)(1)(A) of the National Environmental Policy Act (NEPA) and in the implementing regulations for section 106 of the NHPA at 800.2(a)(1) and 800.2(a)(3).

measures. All questionable materials -- including suspected yet unfamiliar and/or not readily identifiable cultural resources -- will be considered significant by the contractor(s) until significance assessment can be coordinated with the Texas or Louisiana State Historic Preservation Officers (SHPO), the applicable U.S. Army Corps of Engineers (USACE) District office, and the Federal Energy Regulatory Commission (FERC) or their on-site EI.

- (e) If deposits are determined by the SHPO and FERC to be ineligible for inclusion in the National Register of Historic Places (NRHP), then work may proceed upon notice from the SHPO and FERC.
- (f) If determined to have a research potential by the SHPO and FERC, then the portion of the excavation in which the discovery was made shall be avoided and protected. If the site is from a Native American occupation, GPP will notify federally recognized Indian tribes with an interest in the project area. If significant cultural resources are present and cannot be avoided, then impacts will be mitigated through a SHPO and FERC approved data recovery plan. If deposits are determined by the SHPO and FERC to be ineligible for inclusion in the NRHP, then work may proceed.

### **2.3 Discovery of Unmarked Burials or Human Remains**

Marked or unmarked burials may be encountered where an oval or regular soil stain is observed, near partially or completely buried grave markers, or in association with metal hardware commonly used for casket construction. If a suspected burial is encountered, the steps outlined in Section 2.2 will be followed. The project archaeologist will take steps necessary to confirm the presence of a burial shaft; however, only limited and shallow excavation necessary to confirm this presence will be conducted. As set forth in Section 2.2 above, all work will cease within 100 feet of the confirmed grave shaft.

Human remains are often fragile and should be treated with care and respect at all times. The discovery of human remains involves both legal and cultural issues. As such, immediately upon the discovery of human remains, the above listed measures as well as the following procedures will be implemented;

- (a) stop all excavation work and, using appropriate safety precautions, with a minimum of further disturbance to the remains, allow a qualified archaeologist to verify that the discovery is, in fact, human skeletal material;
- (b) if the remains are determined to be human, the archaeologist will contact the local Police and/or Sheriff Department to report the discovery. In addition to the Sheriff, the County Coroner and/or Medical Examiner will also be contacted and informed of the discovery. Additionally, the applicable State SHPO office, FERC or the on-site EI, and the U.S. Army Corps of Engineers District office will be notified;

- (c) GPP will take actions appropriate to the circumstances, including the actions and instructions of the responding law enforcement agency (if any); and
- (d) work within the immediate vicinity of the find (i.e., within 100 foot radius) shall remain halted until the SHPO, FERC and relevant agencies provide written authorization for work to resume in the vicinity of the discovery. If the SHPO representatives determine that the discovery is associated with Native American descent, GPP will notify federally recognized Indian tribes with an interest in the project area and discuss appropriate treatment. Treatment measures may include but not limited to mapping, photography, limited probing and sample collection, or other activity. Stabilization and other protective measures may also be required, including the placement of temporary, sterile fill material over the remains and police protection or fencing.

### 3.0 CONTACTS

It is generally anticipated that the project archaeologist will be present if a discovery is made. This section of the document provides a list of contacts that the project supervisor, site foreman, or area foreman may use should an unanticipated discovery be made during construction in the archaeologist's absence. The following should be contacted, in sequential order:

#### **1) GPP – Environmental Project Manager**

Primary Contact: Mark Burley  
(281) 654-4622 office  
(832) 776-3650 cell phone

Alternate Contact: Bryan Trimm  
(832) 624-3421 office  
(281) 381-3743 cell phone

#### **2) exp Energy Services Inc. – Environmental Project Manager**

Primary Contact: Mike Aubele  
(713) 439-3606 office  
(713) 985-9914 cell phone

#### **3) HRA Gray & Pape, LLC – Archaeological Contact**

Primary Contact: Tony Scott  
(713) 541-0473 office  
(713) 299-6917 cell phone

Alternate Contact: James Hughey  
(713) 541-0473 office  
(713) 542-0943 cell phone

*IF SO INSTRUCTED BY 1) or 2) above, additional contacts may include:*

**Local Law Enforcement**

*If human remains are encountered, dial 911 and specify that it is not a life threatening situation. Request contact with the County/Parish Coroner or Sheriff's office.*

**Texas Historical Commission/State Historic Preservation Office**

Primary Contact Archeology Division Main Number  
(512) 463-6096

**Louisiana Office of Cultural Development, Division of Archaeology/State Historic Preservation Office**

Primary Contact Division of Archeology Main Number  
(225) 342-8170

**Federal Energy Regulatory Commission**

Primary Contact Eric Howard  
(202) 502-6263

**U.S. Army Corps of Engineers – Galveston District**

Primary Contact Felicity Dodson  
(409) 766-3105

**U.S. Army Corps of Engineers – New Orleans District**

Primary Contact James Little, Jr.  
(225) 342-3099

**NOTES:** Contact information will be updated as necessary.



**APPENDIX E**  
**Summary of Soil Limitations along the Project**

APPENDIX E

Soil Limitations for the Gulf LNG Export Project

Limitation <u>a</u>	Project Component												
	GPX Terminal	MP 1 CS	NGPL Inter.	MP 33 CS	Texoma Inter. (MP 33)	Calcasieu Loop	Tennessee Gas Inter. (MP 63)	MP 66 CS	TETCO Inter. (MP 66)	Transco Inter. (MP 68)	Access Roads	ATWS	Pipe Storage Yard
<b>CONSTRUCTION</b>													
Poorly Drained <u>b</u>	831.8	10.3	4.6	7.5	3.6	16.3	4.2	19.3	1.1	3.8	15.6	3.6	0.0
Hydric	831.8	10.3	4.6	0.0	0.1	16.3	4.2	19.3	1.1	3.8	13.5	3.6	13.0
Prime Farmland (Class)	0.0	0.0	0.0	7.5	3.5	9.7	3.3	18.7	0.9	3.8	7.9	0.5	13.0
Poor Revegetation Potential <u>c</u>	0.0	0.0	0.0	0.0	0.0	0.0	0.0	0.0	0.0	0.0	0.0	0.0	0.0
Highly Wind Erodible <u>d</u>	34.2	0.0	0.0	0.0	0.0	9.7	3.3	18.7	0.9	3.8	6.0	0.5	0.0
Highly Water Erodible <u>e</u>	0.0	0.0	0.0	7.5	3.6	16.3	4.2	19.3	1.1	3.8	7.9	0.5	13.0
Stony- Rocky <u>f</u>	0.0	0.0	0.0	0.0	0.0	0.0	0.0	0.0	0.0	0.0	0.0	0.0	0.0
High Compaction Potential	831.8	10.3	4.6	0.0	0.1	16.3	4.2	19.3	1.1	3.8	13.5	3.6	13.0
Shallow Bedrock <u>g</u>	0.0	0.0	0.0	0.0	0.0	0.0	0.0	0.0	0.0	0.0	0.0	0.0	0.0
<b>OPERATION</b>													
Poorly Drained <u>b</u>	760.4	9.7	1.5	7.1	0.9	12.8	1.1	14.8	0.2	0.8	15.4	0.0	0.0
Hydric	760.4	9.7	1.5	0.0	0.0	12.8	1.1	14.8	0.2	0.8	13.3	0.0	0.0
Prime Farmland (Class)	0.0	0.0	0.0	7.1	0.9	6.3	0.3	14.1	0.2	0.8	7.7	0.0	0.0

APPENDIX E (continued)

Soil Limitations for the Gulf LNG Export Project

Limitation <b>a</b>	Project Component												
	GPX Terminal	MP 1 CS	NGPL Inter.	MP 33 CS	Texoma Inter. (MP 33)	Calcasieu Loop	Tennessee Gas Inter. (MP 63)	MP 66 CS	TETCO Inter. (MP 66)	Transco Inter. (MP 68)	Access Roads	ATWS	Pipe Storage Yard
Poor Revegetation Potential <b>c</b>	0.0	0.0	0.0	0.0	0.0	0.0	0.0	0.0	0.0	0.0	0.0	0.0	0.0
Highly Wind Erodible <b>d</b>	33.6	0.0	0.0	0.0	0.0	6.3	0.3	14.1	0.2	0.8	5.8	0.0	0.0
Highly Water Erodible <b>e</b>	0.0	0.0	0.0	7.1	0.9	12.8	1.1	14.8	0.2	0.8	8.3	0.0	0.0
Stony- Rocky <b>f</b>	0.0	0.0	0.0	0.0	0.0	0.0	0.0	0.0	0.0	0.0	0.0	0.0	0.0
High Compaction Potential	796.0	11.4	1.5	0.0	0.0	12.8	1.1	14.8	0.2	0.8	13.3	0.0	0.0
Shallow Bedrock <b>g</b>	0.0	0.0	0.0	0.0	0.0	0.0	0.0	0.0	0.0	0.0	0.0	0.0	0.0

Notes:

CS = Compressor Station

Inter. = Interconnect

**a** For soils in a complex, limitation was selected even if only one (1) of the soil series has the limitation.

**b** Includes somewhat poorly and very poorly drained.

**c** Includes coarse-textured surface textures (fine sand or coarser) that are in well drained, somewhat excessively, or excessively drained soils; typically referred to as droughty.

**d** Wind Erodibility Groups 1, 2 and 3.

**e** K factors from 0.40 to 0.69.

**f** Rock fragments over 3 inches.

**g** 60 inches or more deep over bedrock.

**APPENDIX F**  
**Spill Prevention, Control, and Countermeasures (SPCC) Plan**

Public Version



**Golden Pass LNG Export Project**

**Docket No. CP14-\_\_-000**

**Spill Prevention, Control, and Countermeasures Plan**

**Final**

July 2014

# Golden Pass LNG Export Project Spill Prevention, Control, and Countermeasures Plan

## TABLE OF CONTENTS

1.0 INTRODUCTION.....	1
2.0 TRAINING.....	2
3.0 SPILL PREVENTION.....	3
4.0 EQUIPMENT AND MATERIALS.....	4
5.0 EMERGENCY NOTIFICATION PROCEDURE.....	5
6.0 SPILL CONTAINMENT AND COUNTERMEASURES.....	5
6.1 Land-Based.....	6
6.2 On Water.....	6

## APPENDIX

- Appendix A Facility Contact List for Construction
- Appendix B Initial Discharge/Spill Notification Information Form

## Golden Pass LNG Export Project Spill Prevention, Control, and Countermeasures Plan

### LIST OF ACRONYMS AND ABBREVIATIONS

Bcfd	Billion cubic feet per day
Calcasieu Loop	24-inch diameter pipeline loop
EI	Environmental Inspector
FERC	Federal Energy Regulatory Commission
Golden Pass	Collectively, GPP and GPPL
GPLNG	Golden Pass LNG Terminal LLC
GPLNG Terminal	Existing GPLNG LNG import terminal
GPP	Golden Pass Products LLC
GPPL	Golden Pass Pipeline LLC
GP Pipeline	Existing GPPL pipeline system
GPX Pipeline	Golden Pass Export Pipeline
GPX Project	Golden Pass LNG Export Project
GPX Terminal	Golden Pass LNG Export Terminal
HDD	Horizontal Directional Drill
HDDMCP	HDD Monitoring and Contingency Plan
hp	Horsepower
LNG	Liquefied natural gas
MP	Mile Post
MSDS	Material Safety Data Sheet
NGA	Natural Gas Act
NGPL	Natural Gas Pipeline Company of America
Procedures	FERC's Wetland and Waterbody Construction and Mitigation Procedures
SNWW	Sabine-Neches Waterway
SPCC Plan	Spill Prevention, Control, and Countermeasures
TETCO	Texas Eastern Transmission, LP
Tennessee Gas	Tennessee Gas Pipeline Company, L.L.C.
Texoma	Texoma Pipeline Company
Transco	Transcontinental Gas Pipe Line Company, LLC

## Golden Pass LNG Export Project Spill Prevention, Control, and Countermeasures Plan

### 1.0 INTRODUCTION

Golden Pass Products LLC (“GPP”) and Golden Pass Pipeline LLC (“GPPL”, collectively with GPP, referred to as “Golden Pass”) are requesting authorization from the Federal Energy Regulatory Commission (“FERC”) pursuant to Sections 3 and 7 of the Natural Gas Act (“NGA”), respectively, to site, construct and operate a liquefied natural gas (“LNG”) export project (“GPX Project”) along with associated new compression and loop pipeline facilities. The GPX Project consists of the following:

1. Liquefaction facilities (“GPX Terminal”) to be constructed contiguous to and integrated with Golden Pass LNG Terminal LLC’s (“GPLNG”) existing import terminal site (“GPLNG Terminal”) located onshore along the Sabine-Neches Waterway (“SNWW”) in Jefferson County, Texas; and
2. Modification of GPPL’s existing pipeline system (“GP Pipeline”) by construction of approximately three (3) miles of new 24-inch pipeline loop, three (3) new compressor stations, and necessary modifications to interconnections for bi-directional service (collectively, the “GPX Pipeline”). The GPX Pipeline includes the following initiatives:
  - Installation of approximately three (3) miles of new 24-inch diameter pipeline loop (“Calcasieu Loop”) between surface facilities operated by Texas Eastern Transmission LP (“TETCO”) and Tennessee Gas Pipeline Company, L.L.C. (“Tennessee Gas”) in Calcasieu Parish, Louisiana. The Calcasieu Loop will be installed parallel and adjacent to the GP Pipeline mainline between Mile Post (“MP”) 63 and MP 66 in an area largely managed for timber production.
  - Installation of three (3) compressor stations (approximately 120,000 site-rated brake horsepower [“hp”] total) to facilitate the receipt and delivery of a maximum of 2.7 billion cubic feet per day (“Bcf”) of natural gas supply to the proposed GPX Terminal. These compressors will be installed at the following locations:
    - The MP 1 Compressor Station will be located near the interconnection with the Natural Gas Pipeline Company of America’s (“NGPL”) pipeline. The compressor station will be sited in an open land area previously used for oil and gas extraction adjacent to the existing GP Pipeline and situated in the southwest corner of the GPLNG Terminal site in Jefferson County, Texas.
    - The MP 33 Compressor Station will be located near the interconnection with the Texoma Pipeline Company’s (“Texoma”) pipeline. The MP 33 Compressor Station will be sited in an upland forested area of Orange County, Texas.
    - The MP 66 Compressor Station will be located near the interconnection with the TETCO’s pipeline. The compressor station will be sited in a recently cleared area managed for silviculture (tree farming) in Calcasieu Parish, Louisiana.
  - Aboveground modifications and upgrades to existing interconnections will be required for bi-directional flow capabilities and increased throughput. Existing interconnections to be modified and upgraded are as follows:
    - NGPL interconnect (near MP 1), Jefferson County, Texas;



- Texoma interconnect (near MP 33), Orange County, Texas;
- Tennessee Gas interconnect (near MP 63), Calcasieu Parish, Louisiana;
- TETCO interconnect (near MP 66), Calcasieu Parish, Louisiana; and
- Transcontinental Gas Pipe Line Company, LLC (“Transco”) interconnect (near MP 68), Calcasieu Parish, Louisiana.

The GPX Project will provide shippers the ability to deliver natural gas from domestic sources to the GPX Terminal via the GPX Pipeline. The GPX Terminal will convert natural gas to LNG, which will be stored and exported using GPLNG Terminal facilities. The GPX Project facilities will be constructed and operated contiguous to and integrated with the GPLNG Terminal and GP Pipeline.<sup>1</sup> Golden Pass will be designed to optimize the existing import terminal and pipeline infrastructure. Through the GPX Project, Golden Pass and GPLNG will offer both import and export services (not simultaneously) for LNG from one (1) set of facilities, strategically located to access the Gulf Coast waters for further delivery to market.

The proposed GPX Project design will use existing import terminal and pipeline facilities to the maximum extent possible, locating new facilities adjacent to existing facilities, connecting with third party pipelines to optimize compression and thereby minimizing the footprint of the new facilities. The GPX Project will be constructed and operated in a manner that minimizes any potential adverse effects to the environment, local residents, and communities.

The purpose of this Spill Prevention, Control, and Countermeasures (“SPCC”) Plan is to avoid or minimize effects to the environment in the event of spills of fuels, lubricants, chemicals, hydraulic fluid or other hazardous materials during GPX Project construction. This includes the refueling or servicing of all equipment and the Plan is intended to comply with the requirements of Section IV of the FERC’s *Wetland and Waterbody Construction and Mitigation Procedures*<sup>2</sup> (May 2013) (“Procedures”), with site-specific variances (see **Resource Report No. 2**), and is designed to complement existing laws, regulations, rules, standards, policies and procedures pertaining to safety standards and pollution rules, in order to minimize the potential for unauthorized releases of fuel, lubricants, chemicals, hydraulic fluid, lubricants or other hazardous materials. While the SPCC Plan is intended to identify necessary preventative measures for foreseeable potential unauthorized releases, not every potential situation can be foreseen.

*This SPCC Plan applies to all construction and reclamation activities of the GPX Project. The operating phase of the project is not covered in this SPCC Plan.*

## 2.0 TRAINING

Training is a key component of assuring that employees and contractors at the GPX Project site are aware of the SPCC Plan and understand how to comply with the Plan. The GPX Project Manager, or his/her designee, and the Environmental Inspector (“EI”) will be responsible for assuring that the requirements of this section are completed. Specific training requirements include:

---

<sup>1</sup> See FERC Docket No. CP04-386-000 for the GPLNG Terminal facilities and Docket Nos. CP04-400-000, CP04-401-000 and CP04-402-000 for the GP Pipeline facilities. *Golden Pass LNG Terminal LP and Golden Pass Pipeline LP*, 112 FERC ¶ 61,041 (2005), *amended*, *Golden Pass Pipeline LP*, 117 FERC ¶ 61,015, *further amended*, 117 FERC ¶ 61,332 (2006).

<sup>2</sup> Golden Pass proposes to adopt FERC’s 2013 *Wetland and Waterbody Construction Procedures*, with site-specific variances. A copy of the requested variances is provided in Resource Report No. 2.

1. Personnel responsible for handling fuel, lubricants, chemicals, hydraulic fluid or other hazardous materials will receive training on the requirements of this Plan;
2. Handling of fuel, lubricants, chemicals, hydraulic fluid or hazardous materials will be conducted by personnel who have been trained for the specific task; and
3. The training specified above will be completed prior to commencing activities or carrying out tasks associated with such materials.

### **3.0 SPILL PREVENTION**

Planning undertaken prior to construction includes detailed preparation to assure that any hazardous materials, chemicals, fuels, lubricating oils, hydraulics or other such materials required for construction tasks are secured in containers manufactured for their designated purpose. At the proposed GPX Project construction site, these materials would be stored in a secured area.

The following spill prevention measures will be implemented by Golden Pass:

1. Golden Pass will require all contractors to ensure that all equipment is in good operating order and inspected on a regular basis;
2. Fuel trucks transporting fuel to on-site equipment will travel only on approved access roads;
3. Fuels and lubricants will be stored only at designated staging areas. As part of the construction contract, guidelines will be established to minimize the potential for fuels and lubricants to enter waters of the U.S.;
4. Golden Pass will require its contractors to perform all routine equipment maintenance at the designated staging areas and contain, collect and dispose of wastes in an appropriate manner;
5. Secondary containment will be utilized around any above-ground bulk tanks, drums or storage containers (if single-walled), so that potential spill materials will be contained and collected in specified areas isolated from any wetlands and waterbodies. Double-walled tanks, if used, will be manually filled and attended while filling. Tanks, drums or any containers will not be placed in areas subject to periodic flooding or washout;
6. A supply of sorbent and barrier materials sufficient to allow the rapid containment and recovery of any spill will be maintained at the project site. Sorbent and barrier materials will also be utilized to contain runoff from contaminated areas;
7. Shovels and storage containers will be kept at the project site. In the event that small quantities of soil become contaminated, shovels will be utilized to collect the soil and the material will be stored in a sealed container. Large quantities of contaminated soil may be bio-remediated on-site, subject to government and Golden Pass approval and/or landowner permission, or collected utilizing heavy equipment, and stored in drums or other suitable containers prior to disposal;
8. Should contamination occur adjacent to areas as a result of runoff, shovels and/or heavy equipment will be utilized to collect the contaminated material. Contaminated soil will be disposed of in accordance with State and Federal regulations;
9. All containers and fuel tanks will be subject to visual inspection on a daily basis and when the tank is refilled. Tanks will be monitored continuously so that potential leaks or spills will be quickly detected;
10. Visible fuel leaks will be stopped or contained immediately, then reported to the contractor's

- and Golden Pass' designated representative, and cleaned up as soon as reasonably possible;
11. Drain valves on secondary containments will be closed and locked to prevent accidental or unauthorized discharges from the tank. All stormwater collected in the secondary containments will be inspected for trash or sheen prior to discharge. Any sheen will be removed with absorbent pads, and disposed of properly prior to discharge. Trash will be removed prior to discharge of stormwater. If collected stormwater cannot be cleared of sheen or debris, an approved vendor will be utilized to remove contaminated stormwater and disposed of in accordance with state and federal regulations;
  12. All equipment will be parked overnight and/or fueled at least 100 feet from a waterbody or in an upland area at least 100 feet from a wetland boundary, unless otherwise approved by FERC<sup>2</sup>. These activities can also occur closer only if the EI determines that there is no reasonable alternative, and the project sponsor and its contractors have taken appropriate steps (including secondary containment structures) to prevent spills and provide for prompt cleanup in the event of a spill. Where conditions require that construction equipment (e.g., barge equipment, dewatering pumps) be refueled within 100 feet of water bodies or wetlands, these operations must be manned continuously to ensure that over filling, leaks or spills do not occur;
  13. Hazardous materials, including fuel, lubricants, chemicals and hydraulic fluid, will not be stored within 100 feet of a wetland, waterbody or designated municipal watershed area, unless otherwise approved by FERC<sup>2</sup>. Where stationary equipment must remain within 100 feet of a waterbody or wetland, adequate secondary containment must be provided;
  14. Concrete coating activities will not be performed within 100 feet of a wetland or waterbody boundary, unless otherwise approved by FERC<sup>2</sup>. These activities may occur closer only if the EI determines that there is no reasonable alternative, and the project sponsor and its contractors have taken appropriate steps (including secondary containment structures) to prevent spills and provide for prompt cleanup in the event of a spill; and
  15. Pumps operating within 100 feet of a waterbody or wetland boundary will utilize appropriate secondary containment systems to prevent spills.

#### **4.0 EQUIPMENT AND MATERIALS**

Each contractor is required to provide a material safety data sheet ("MSDS") and the expected usage quantities (as well as the maximum quantity expected to be on site at any one time) for any potentially hazardous material brought to the site. The site EI will review the MSDSs, determine handling, storage or usage restrictions/requirements that are appropriate, and communicate any restrictions to the contractor.

Typical materials subject to this SPCC Plan include:

1. Fuels, oils and greases needed for operation and maintenance of construction equipment;
2. Paints, other protective coatings, and solvents; and
3. Materials for the batching of concrete.

The individual types of materials would be segregated and stored in accordance with manufacturers' recommendations and all applicable State or Federal laws. The quantities of these materials that will be allowed on site at any one (1) time would be limited to that required as short-term supply. The exact quantities of materials allowed will be determined as part of the pre-construction planning activity.

Spill response equipment, in the form of portable Spill Response Kits, will be available on-site or at each construction spread and wherever potentially hazardous materials are handled or stored. This equipment will be readily available to respond to a hazardous material spill or release. Such equipment will include, but not be limited to, the following:

1. Personal Protective Equipment (i.e. gloves, goggles);
2. Absorbent materials (Pads and Booms) and storage containers; and
3. Small shovel.

Contractors will be responsible for inspecting spill kits weekly as well as maintaining and restocking equipment and supplies as needed.

## **5.0 EMERGENCY NOTIFICATION PROCEDURE**

The employee or contractor who first discovers the spill is responsible for initiating the spill containment and reporting procedures. The employee or contractor will need to use their best judgment to determine whether they can safely contain the spill or whether they will require additional resources to provide safe containment; regardless of the decision, the employee or contractor should notify their supervisor or the site environmental inspector as soon as it is feasible to do so. Once the safety of all persons in the area has been ensured and once the spill response team has taken control of the spill, the employee or contractor will report the spill to the site environmental inspector, the project management team and the safety department.

This team would then initiate the attached emergency notification procedure to comply with Federal and State requirements for a reportable release of a hazardous substance or a spill of oil. A facility contact list is provided as Appendix A to this SPCC Plan. An initial discharge/spill notification information form is provided as Appendix B.

## **6.0 SPILL CONTAINMENT AND COUNTERMEASURES**

In the event of a spill of hazardous material, the contractor will:

1. Immediately notify the Golden Pass designated representative and/or EI;
2. Identify the product hazards related to the spilled material and implement appropriate safety measures, based on the nature of the hazard;
3. Isolate or shutdown the source of the spill if it can be done safely;
4. Block culverts to limit spill travel;
5. Initiate containment procedures to limit the spill to as small an area as possible, to prevent damage to property or areas of environment concern (e.g., watercourses); and
6. Commence recovery of the spill and clean-up operations.

When notified of a spill, the Golden Pass designated representative will immediately ensure that:

1. Action is taken to control danger to the public and personnel in the project area;
2. Spill contingency plans are implemented and that necessary equipment and manpower are available and mobilized if required;

3. Measures are taken to isolate or shutdown the source of the spill;
4. All resources necessary to contain, recover and clean up the spill are available;
5. Any resources requested by the contractor are provided; and
6. Appropriate agencies are notified.

## **6.1 LAND-BASED**

On a land spill, actions will immediately be taken to physically contain the spill (i.e. absorbent pads, socks, kitty litter, etc). Personnel entry and travel on contaminated soils will be limited to that which is necessary for control and cleanup activities. Sorbent materials will be applied as needed to contain or clean up the spilled material. Contaminated sorbent materials, soil and vegetation will also be collected and disposed of at an approved facility.

## **6.2 ON WATER**

A floating boom will be immediately deployed to provide an additional containment measure. Spilled material will be collected with the use of a suction pump, buckets or absorbent materials and placed into a suitable container(s) and disposed of at an approved facility.

## APPENDICES

## Appendix A

### GPX Project Contact List

### GPX Project Contact List

Title	Name	Phone No.
Site Manager		
Construction Project Manager		
Environmental Inspector ("EI")		
Contractor #1		
Contractor #2		
Contractor #3		
Contractor #4		
Environmental Response Team		
National Response Center		800.424.8802
Texas Commission on Environmental Quality Emergency Response		800.832.8224
Port Arthur Police Department Emergency Management	Deputy Chief John Owens	409.983.8616
Port Arthur Fire Department		409.983.8700
Jefferson County Health District		409.835.8530
Jefferson County Emergency Management		409.722.4371
Jefferson County Emergency Dispatch		911
St. Mary's Hospital 3600 Gates Blvd. Port Arthur, TX		409.989.5490
Doctors Hospital 5500 39th Street Groves, TX		409.962.5733



Appendix B  
Initial Discharge/Spill Notification Information Form

## Initial Discharge/Spill Notification Information Form

1. Date / Time of NRC Call \_\_\_\_ / \_\_\_\_ / \_\_\_\_ : \_\_\_\_ NRC Contact: \_\_\_\_\_
2. Date / Time of State Call \_\_\_\_ / \_\_\_\_ / \_\_\_\_ : \_\_\_\_ State Contact: \_\_\_\_\_
3. Name of person reporting \_\_\_\_\_
4. Address \_\_\_\_\_
5. Phone No. \_\_\_\_\_
6. Description or Identification of Substance Spilled \_\_\_\_\_  
\_\_\_\_\_
7. Estimated Quantity Discharged/Spilled \_\_\_\_\_
8. Date/Time of Release \_\_\_\_ / \_\_\_\_ / \_\_\_\_ : \_\_\_\_ Duration of the Incident \_\_\_\_\_
9. Weather Conditions (temperature, wind speed/direction, clear/cloudy/rain) \_\_\_\_\_  
\_\_\_\_\_
10. Name of the Surface Water Body affected or threatened \_\_\_\_\_
11. Source of the Discharge/Spill \_\_\_\_\_
12. Description of the Environmental Impact (e.g. size of affected area, environmentally sensitive area or natural resource, etc.) \_\_\_\_\_  
\_\_\_\_\_
13. Name of Person Responsible for Site \_\_\_\_\_
14. Address \_\_\_\_\_ Phone No. \_\_\_\_\_
15. Name of Site Environmental Contact \_\_\_\_\_
16. Address \_\_\_\_\_ Phone No. \_\_\_\_\_
17. Actions Taken \_\_\_\_\_
18. Actions Being Taken \_\_\_\_\_
19. Actions to be Taken \_\_\_\_\_

Initial Discharge/Spill Notification Information Form  
(Continued)

20. Known or Anticipated Health Risks \_\_\_\_\_

21. Identity of any Local, State, or Federal Authorities or 3rd Parties Responding to Spill \_\_\_\_\_

---

22. Other Significant Information:

**APPENDIX G**  
**FERC's Upland Erosion Control, Revegetation, and Maintenance Plan**  
**(FERC's Plan)**

**UPLAND EROSION CONTROL, REVEGETATION, AND  
MAINTENANCE PLAN**

**UPLAND EROSION CONTROL, REVEGETATION, AND  
MAINTENANCE PLAN**

**TABLE OF CONTENTS**

I. <u>APPLICABILITY</u> .....	1
II. <u>SUPERVISION AND INSPECTION</u> .....	2
A. ENVIRONMENTAL INSPECTION .....	2
B. RESPONSIBILITIES OF ENVIRONMENTAL INSPECTORS .....	2
III. <u>PRECONSTRUCTION PLANNING</u> .....	4
A. CONSTRUCTION WORK AREAS .....	4
B. DRAIN TILE AND IRRIGATION SYSTEMS .....	4
C. GRAZING DEFERMENT .....	5
D. ROAD CROSSINGS AND ACCESS POINTS .....	5
E. DISPOSAL PLANNING .....	5
F. AGENCY COORDINATION .....	5
G. SPILL PREVENTION AND RESPONSE PROCEDURES .....	6
H. RESIDENTIAL CONSTRUCTION .....	6
I. WINTER CONSTRUCTION PLANS .....	6
IV. <u>INSTALLATION</u> .....	7
A. APPROVED AREAS OF DISTURBANCE .....	7
B. TOPSOIL SEGREGATION .....	8
C. DRAIN TILES .....	9
D. IRRIGATION .....	9
E. ROAD CROSSINGS AND ACCESS POINTS .....	9
F. TEMPORARY EROSION CONTROL .....	9
1. Temporary Slope Breakers .....	9
2. Temporary Trench Plugs .....	10
3. Sediment Barriers .....	10
4. Mulch .....	11
V. <u>RESTORATION</u> .....	12
A. CLEANUP .....	12
B. PERMANENT EROSION CONTROL DEVICES .....	13
1. Trench Breakers .....	13
2. Permanent Slope Breakers .....	14
C. SOIL COMPACTION MITIGATION .....	14
D. REVEGETATION .....	15
1. General .....	15
2. Soil Additives .....	15
3. Seeding Requirements .....	15
VI. <u>OFF-ROAD VEHICLE CONTROL</u> .....	16
VII. <u>POST-CONSTRUCTION ACTIVITIES AND REPORTING</u> .....	17
A. MONITORING AND MAINTENANCE .....	17
B. REPORTING .....	18

## **UPLAND EROSION CONTROL, REVEGETATION, AND MAINTENANCE PLAN (PLAN)**

### **I. APPLICABILITY**

- A. The intent of this Plan is to assist project sponsors by identifying baseline mitigation measures for minimizing erosion and enhancing revegetation. Project sponsors shall specify in their applications for a new FERC authorization and in prior notice and advance notice filings, any individual measures in this Plan they consider unnecessary, technically infeasible, or unsuitable due to local conditions and fully describe any alternative measures they would use. Project sponsors shall also explain how those alternative measures would achieve a comparable level of mitigation.

Once a project is authorized, project sponsors can request further changes as variances to the measures in this Plan (or the applicant's approved plan). The Director of the Office of Energy Projects (Director) will consider approval of variances upon the project sponsor's written request, if the Director agrees that a variance:

1. provides equal or better environmental protection;
2. is necessary because a portion of this Plan is infeasible or unworkable based on project-specific conditions; or
3. is specifically required in writing by another federal, state, or Native American land management agency for the portion of the project on its land or under its jurisdiction.

Sponsors of projects planned for construction under the automatic authorization provisions in the FERC's regulations must receive written approval for any variances in advance of construction.

Project-related impacts on wetland and waterbody systems are addressed in the staff's Wetland and Waterbody Construction and Mitigation Procedures (Procedures).

## II. SUPERVISION AND INSPECTION

### A. ENVIRONMENTAL INSPECTION

1. At least one Environmental Inspector is required for each construction spread during construction and restoration (as defined by section V). The number and experience of Environmental Inspectors assigned to each construction spread shall be appropriate for the length of the construction spread and the number/significance of resources affected.
2. Environmental Inspectors shall have peer status with all other activity inspectors.
3. Environmental Inspectors shall have the authority to stop activities that violate the environmental conditions of the FERC's Orders, stipulations of other environmental permits or approvals, or landowner easement agreements; and to order appropriate corrective action.

### B. RESPONSIBILITIES OF ENVIRONMENTAL INSPECTORS

At a minimum, the Environmental Inspector(s) shall be responsible for:

1. Inspecting construction activities for compliance with the requirements of this Plan, the Procedures, the environmental conditions of the FERC's Orders, the mitigation measures proposed by the project sponsor (as approved and/or modified by the Order), other environmental permits and approvals, and environmental requirements in landowner easement agreements.
2. Identifying, documenting, and overseeing corrective actions, as necessary to bring an activity back into compliance;
3. Verifying that the limits of authorized construction work areas and locations of access roads are visibly marked before clearing, and maintained throughout construction;
4. Verifying the location of signs and highly visible flagging marking the boundaries of sensitive resource areas, waterbodies, wetlands, or areas with special requirements along the construction work area;
5. Identifying erosion/sediment control and soil stabilization needs in all areas;
6. Ensuring that the design of slope breakers will not cause erosion or direct water into sensitive environmental resource areas, including cultural resource sites, wetlands, waterbodies, and sensitive species habitats;



7. Verifying that dewatering activities are properly monitored and do not result in the deposition of sand, silt, and/or sediment into sensitive environmental resource areas, including wetlands, waterbodies, cultural resource sites, and sensitive species habitats; stopping dewatering activities if such deposition is occurring and ensuring the design of the discharge is changed to prevent reoccurrence; and verifying that dewatering structures are removed after completion of dewatering activities;
8. Ensuring that subsoil and topsoil are tested in agricultural and residential areas to measure compaction and determine the need for corrective action;
9. Advising the Chief Construction Inspector when environmental conditions (such as wet weather or frozen soils) make it advisable to restrict or delay construction activities to avoid topsoil mixing or excessive compaction;
10. Ensuring restoration of contours and topsoil;
11. Verifying that the soils imported for agricultural or residential use are certified as free of noxious weeds and soil pests, unless otherwise approved by the landowner;
12. Ensuring that erosion control devices are properly installed to prevent sediment flow into sensitive environmental resource areas (e.g., wetlands, waterbodies, cultural resource sites, and sensitive species habitats) and onto roads, and determining the need for additional erosion control devices;
13. Inspecting and ensuring the maintenance of temporary erosion control measures at least:
  - a. on a daily basis in areas of active construction or equipment operation;
  - b. on a weekly basis in areas with no construction or equipment operation; and
  - c. within 24 hours of each 0.5 inch of rainfall;
14. Ensuring the repair of all ineffective temporary erosion control measures within 24 hours of identification, or as soon as conditions allow if compliance with this time frame would result in greater environmental impacts;
15. Keeping records of compliance with the environmental conditions of the FERC's Orders, and the mitigation measures proposed by the project sponsor in the application submitted to the FERC, and other federal or state environmental permits during active construction and restoration;

16. Identifying areas that should be given special attention to ensure stabilization and restoration after the construction phase; and
17. Verifying that locations for any disposal of excess construction materials for beneficial reuse comply with section III.E.

### III. PRECONSTRUCTION PLANNING

The project sponsor shall do the following before construction:

#### A. CONSTRUCTION WORK AREAS

1. Identify all construction work areas (e.g., construction right-of-way, extra work space areas, pipe storage and contractor yards, borrow and disposal areas, access roads) that would be needed for safe construction. The project sponsor must ensure that appropriate cultural resources and biological surveys are conducted, as determined necessary by the appropriate federal and state agencies.
2. Project sponsors are encouraged to consider expanding any required cultural resources and endangered species surveys in anticipation of the need for activities outside of authorized work areas.
3. Plan construction sequencing to limit the amount and duration of open trench sections, as necessary, to prevent excessive erosion or sediment flow into sensitive environmental resource areas.

#### B. DRAIN TILE AND IRRIGATION SYSTEMS

1. Attempt to locate existing drain tiles and irrigation systems.
2. Contact landowners and local soil conservation authorities to determine the locations of future drain tiles that are likely to be installed within 3 years of the authorized construction.
3. Develop procedures for constructing through drain-tiled areas, maintaining irrigation systems during construction, and repairing drain tiles and irrigation systems after construction.
4. Engage qualified drain tile specialists, as needed to conduct or monitor repairs to drain tile systems affected by construction. Use drain tile specialists from the project area, if available.

C. GRAZING DEFERMENT

Develop grazing deferment plans with willing landowners, grazing permittees, and land management agencies to minimize grazing disturbance of revegetation efforts.

D. ROAD CROSSINGS AND ACCESS POINTS

Plan for safe and accessible conditions at all roadway crossings and access points during construction and restoration.

E. DISPOSAL PLANNING

Determine methods and locations for the regular collection, containment, and disposal of excess construction materials and debris (e.g., timber, slash, mats, garbage, drill cuttings and fluids, excess rock) throughout the construction process. Disposal of materials for beneficial reuse must not result in adverse environmental impact and is subject to compliance with all applicable survey, landowner or land management agency approval, and permit requirements.

F. AGENCY COORDINATION

The project sponsor must coordinate with the appropriate local, state, and federal agencies as outlined in this Plan and/or required by the FERC's Orders.

1. Obtain written recommendations from the local soil conservation authorities or land management agencies regarding permanent erosion control and revegetation specifications.
2. Develop specific procedures in coordination with the appropriate agencies to prevent the introduction or spread of invasive species, noxious weeds, and soil pests resulting from construction and restoration activities.
3. Develop specific procedures in coordination with the appropriate agencies and landowners, as necessary, to allow for livestock and wildlife movement and protection during construction.
4. Develop specific blasting procedures in coordination with the appropriate agencies that address pre- and post-blast inspections; advanced public notification; and mitigation measures for building foundations, groundwater wells, and springs. Use appropriate methods (e.g., blasting mats) to prevent damage to nearby structures and to prevent debris from entering sensitive environmental resource areas.

## G. SPILL PREVENTION AND RESPONSE PROCEDURES

The project sponsor shall develop project-specific Spill Prevention and Response Procedures, as specified in section IV of the staff's Procedures. A copy must be filed with the Secretary of the FERC (Secretary) prior to construction and made available in the field on each construction spread. The filing requirement does not apply to projects constructed under the automatic authorization provisions in the FERC's regulations.

## H. RESIDENTIAL CONSTRUCTION

For all properties with residences located within 50 feet of construction work areas, project sponsors shall: avoid removal of mature trees and landscaping within the construction work area unless necessary for safe operation of construction equipment, or as specified in landowner agreements; fence the edge of the construction work area for a distance of 100 feet on either side of the residence; and restore all lawn areas and landscaping immediately following clean up operations, or as specified in landowner agreements. If seasonal or other weather conditions prevent compliance with these time frames, maintain and monitor temporary erosion controls (sediment barriers and mulch) until conditions allow completion of restoration.

## I. WINTER CONSTRUCTION PLANS

If construction is planned to occur during winter weather conditions, project sponsors shall develop and file a project-specific winter construction plan with the FERC application. This filing requirement does not apply to projects constructed under the automatic authorization provisions of the FERC's regulations.

The plan shall address:

1. winter construction procedures (e.g., snow handling and removal, access road construction and maintenance, soil handling under saturated or frozen conditions, topsoil stripping);
2. stabilization and monitoring procedures if ground conditions will delay restoration until the following spring (e.g., mulching and erosion controls, inspection and reporting, stormwater control during spring thaw conditions); and
3. final restoration procedures (e.g., subsidence and compaction repair, topsoil replacement, seeding).

#### IV. INSTALLATION

##### A. APPROVED AREAS OF DISTURBANCE

1. Project-related ground disturbance shall be limited to the construction right-of-way, extra work space areas, pipe storage yards, borrow and disposal areas, access roads, and other areas approved in the FERC's Orders. Any project-related ground disturbing activities outside these areas will require prior Director approval. This requirement does not apply to activities needed to comply with the Plan and Procedures (i.e., slope breakers, energy-dissipating devices, dewatering structures, drain tile system repairs) or minor field realignments and workspace shifts per landowner needs and requirements that do not affect other landowners or sensitive environmental resource areas. All construction or restoration activities outside of authorized areas are subject to all applicable survey and permit requirements, and landowner easement agreements.
2. The construction right-of-way width for a project shall not exceed 75 feet or that described in the FERC application unless otherwise modified by a FERC Order. However, in limited, non-wetland areas, this construction right-of-way width may be expanded by up to 25 feet without Director approval to accommodate full construction right-of-way topsoil segregation and to ensure safe construction where topographic conditions (e.g., side-slopes) or soil limitations require it. Twenty-five feet of extra construction right-of-way width may also be used in limited, non-wetland or non-forested areas for truck turn-arounds where no reasonable alternative access exists.

Project use of these additional limited areas is subject to landowner or land management agency approval and compliance with all applicable survey and permit requirements. When additional areas are used, each one shall be identified and the need explained in the weekly or biweekly construction reports to the FERC, if required. The following material shall be included in the reports:

- a. the location of each additional area by station number and reference to previously filed alignment sheets, or updated alignment sheets showing the additional areas;
- b. identification of the filing at FERC containing evidence that the additional areas were previously surveyed; and

- c. a statement that landowner approval has been obtained and is available in project files.

Prior written approval of the Director is required when the authorized construction right-of-way width would be expanded by more than 25 feet.

## B. TOPSOIL SEGREGATION

1. Unless the landowner or land management agency specifically approves otherwise, prevent the mixing of topsoil with subsoil by stripping topsoil from either the full work area or from the trench and subsoil storage area (ditch plus spoil side method) in:
  - a. cultivated or rotated croplands, and managed pastures;
  - b. residential areas;
  - c. hayfields; and
  - d. other areas at the landowner's or land managing agency's request.
2. In residential areas, importation of topsoil is an acceptable alternative to topsoil segregation.
3. Where topsoil segregation is required, the project sponsor must:
  - a. segregate at least 12 inches of topsoil in deep soils (more than 12 inches of topsoil); and
  - b. make every effort to segregate the entire topsoil layer in soils with less than 12 inches of topsoil.
4. Maintain separation of salvaged topsoil and subsoil throughout all construction activities.
5. Segregated topsoil may not be used for padding the pipe, constructing temporary slope breakers or trench plugs, improving or maintaining roads, or as a fill material.
6. Stabilize topsoil piles and minimize loss due to wind and water erosion with use of sediment barriers, mulch, temporary seeding, tackifiers, or functional equivalents, where necessary.

## C. DRAIN TILES

1. Mark locations of drain tiles damaged during construction.
2. Probe all drainage tile systems within the area of disturbance to check for damage.
3. Repair damaged drain tiles to their original or better condition. Do not use filter-covered drain tiles unless the local soil conservation authorities and the landowner agree. Use qualified specialists for testing and repairs.
4. For new pipelines in areas where drain tiles exist or are planned, ensure that the depth of cover over the pipeline is sufficient to avoid interference with drain tile systems. For adjacent pipeline loops in agricultural areas, install the new pipeline with at least the same depth of cover as the existing pipeline(s).

## D. IRRIGATION

Maintain water flow in crop irrigation systems, unless shutoff is coordinated with affected parties.

## E. ROAD CROSSINGS AND ACCESS POINTS

1. Maintain safe and accessible conditions at all road crossings and access points during construction.
2. If crushed stone access pads are used in residential or agricultural areas, place the stone on synthetic fabric to facilitate removal.
3. Minimize the use of tracked equipment on public roadways. Remove any soil or gravel spilled or tracked onto roadways daily or more frequent as necessary to maintain safe road conditions. Repair any damages to roadway surfaces, shoulders, and bar ditches.

## F. TEMPORARY EROSION CONTROL

Install temporary erosion controls immediately after initial disturbance of the soil. Temporary erosion controls must be properly maintained throughout construction (on a daily basis) and reinstalled as necessary (such as after backfilling of the trench) until replaced by permanent erosion controls or restoration is complete.

1. Temporary Slope Breakers
  - a. Temporary slope breakers are intended to reduce runoff velocity and divert water off the construction right-of-way. Temporary slope

breakers may be constructed of materials such as soil, silt fence, staked hay or straw bales, or sand bags.

- b. Install temporary slope breakers on all disturbed areas, as necessary to avoid excessive erosion. Temporary slope breakers must be installed on slopes greater than 5 percent where the base of the slope is less than 50 feet from waterbody, wetland, and road crossings at the following spacing (closer spacing shall be used if necessary):

<u>Slope (%)</u>	<u>Spacing (feet)</u>
5 - 15	300
>15 - 30	200
>30	100

- c. Direct the outfall of each temporary slope breaker to a stable, well vegetated area or construct an energy-dissipating device at the end of the slope breaker and off the construction right-of-way.
- d. Position the outfall of each temporary slope breaker to prevent sediment discharge into wetlands, waterbodies, or other sensitive environmental resource areas.

## 2. Temporary Trench Plugs

Temporary trench plugs are intended to segment a continuous open trench prior to backfill.

- a. Temporary trench plugs may consist of unexcavated portions of the trench, compacted subsoil, sandbags, or some functional equivalent.
- b. Position temporary trench plugs, as necessary, to reduce trenchline erosion and minimize the volume and velocity of trench water flow at the base of slopes.

## 3. Sediment Barriers

Sediment barriers are intended to stop the flow of sediments and to prevent the deposition of sediments beyond approved workspaces or into sensitive resources.

- a. Sediment barriers may be constructed of materials such as silt fence, staked hay or straw bales, compacted earth (e.g., driveable berms across travelways), sand bags, or other appropriate materials.



- b. At a minimum, install and maintain temporary sediment barriers across the entire construction right-of-way at the base of slopes greater than 5 percent where the base of the slope is less than 50 feet from a waterbody, wetland, or road crossing until revegetation is successful as defined in this Plan. Leave adequate room between the base of the slope and the sediment barrier to accommodate ponding of water and sediment deposition.
- c. Where wetlands or waterbodies are adjacent to and downslope of construction work areas, install sediment barriers along the edge of these areas, as necessary to prevent sediment flow into the wetland or waterbody.

#### 4. Mulch

- a. Apply mulch on all slopes (except in cultivated cropland) concurrent with or immediately after seeding, where necessary to stabilize the soil surface and to reduce wind and water erosion. Spread mulch uniformly over the area to cover at least 75 percent of the ground surface at a rate of 2 tons/acre of straw or its equivalent, unless the local soil conservation authority, landowner, or land managing agency approves otherwise in writing.
- b. Mulch can consist of weed-free straw or hay, wood fiber hydromulch, erosion control fabric, or some functional equivalent.
- c. Mulch all disturbed upland areas (except cultivated cropland) before seeding if:
  - (1) final grading and installation of permanent erosion control measures will not be completed in an area within 20 days after the trench in that area is backfilled (10 days in residential areas), as required in section V.A.1; or
  - (2) construction or restoration activity is interrupted for extended periods, such as when seeding cannot be completed due to seeding period restrictions.
- d. If mulching before seeding, increase mulch application on all slopes within 100 feet of waterbodies and wetlands to a rate of 3 tons/acre of straw or equivalent.
- e. If wood chips are used as mulch, do not use more than 1 ton/acre and add the equivalent of 11 lbs/acre available nitrogen (at least 50 percent of which is slow release).

- f. Ensure that mulch is adequately anchored to minimize loss due to wind and water.
- g. When anchoring with liquid mulch binders, use rates recommended by the manufacturer. Do not use liquid mulch binders within 100 feet of wetlands or waterbodies, except where the product is certified environmentally non-toxic by the appropriate state or federal agency or independent standards-setting organization.
- h. Do not use synthetic monofilament mesh/netted erosion control materials in areas designated as sensitive wildlife habitat, unless the product is specifically designed to minimize harm to wildlife. Anchor erosion control fabric with staples or other appropriate devices.

## V. RESTORATION

### A. CLEANUP

1. Commence cleanup operations immediately following backfill operations. Complete final grading, topsoil replacement, and installation of permanent erosion control structures within 20 days after backfilling the trench (10 days in residential areas). If seasonal or other weather conditions prevent compliance with these time frames, maintain temporary erosion controls (i.e., temporary slope breakers, sediment barriers, and mulch) until conditions allow completion of cleanup.

If construction or restoration unexpectedly continues into the winter season when conditions could delay successful decompaction, topsoil replacement, or seeding until the following spring, file with the Secretary for the review and written approval of the Director, a winter construction plan (as specified in section III.I). This filing requirement does not apply to projects constructed under the automatic authorization provisions of the FERC's regulations.

2. A travel lane may be left open temporarily to allow access by construction traffic if the temporary erosion control structures are installed as specified in section IV.F. and inspected and maintained as specified in sections II.B.12 through 14. When access is no longer required the travel lane must be removed and the right-of-way restored.
3. Rock excavated from the trench may be used to backfill the trench only to the top of the existing bedrock profile. Rock that is not returned to the trench shall be considered construction debris, unless approved for use as mulch or for some other use on the construction work areas by the landowner or land managing agency.

4. Remove excess rock from at least the top 12 inches of soil in all cultivated or rotated cropland, managed pastures, hayfields, and residential areas, as well as other areas at the landowner's request. The size, density, and distribution of rock on the construction work area shall be similar to adjacent areas not disturbed by construction. The landowner or land management agency may approve other provisions in writing.
5. Grade the construction right-of-way to restore pre-construction contours and leave the soil in the proper condition for planting.
6. Remove construction debris from all construction work areas unless the landowner or land managing agency approves leaving materials onsite for beneficial reuse, stabilization, or habitat restoration.
7. Remove temporary sediment barriers when replaced by permanent erosion control measures or when revegetation is successful.

#### B. PERMANENT EROSION CONTROL DEVICES

1. Trench Breakers
  - a. Trench breakers are intended to slow the flow of subsurface water along the trench. Trench breakers may be constructed of materials such as sand bags or polyurethane foam. Do not use topsoil in trench breakers.
  - b. An engineer or similarly qualified professional shall determine the need for and spacing of trench breakers. Otherwise, trench breakers shall be installed at the same spacing as and upslope of permanent slope breakers.
  - c. In agricultural fields and residential areas where slope breakers are not typically required, install trench breakers at the same spacing as if permanent slope breakers were required.
  - d. At a minimum, install a trench breaker at the base of slopes greater than 5 percent where the base of the slope is less than 50 feet from a waterbody or wetland and where needed to avoid draining a waterbody or wetland. Install trench breakers at wetland boundaries, as specified in the Procedures. Do not install trench breakers within a wetland.

2. Permanent Slope Breakers

- a. Permanent slope breakers are intended to reduce runoff velocity, divert water off the construction right-of-way, and prevent sediment deposition into sensitive resources. Permanent slope breakers may be constructed of materials such as soil, stone, or some functional equivalent.
- b. Construct and maintain permanent slope breakers in all areas, except cultivated areas and lawns, unless requested by the landowner, using spacing recommendations obtained from the local soil conservation authority or land managing agency.

In the absence of written recommendations, use the following spacing unless closer spacing is necessary to avoid excessive erosion on the construction right-of-way:

<u>Slope (%)</u>	<u>Spacing (feet)</u>
5 - 15	300
>15 - 30	200
>30	100

- c. Construct slope breakers to divert surface flow to a stable area without causing water to pool or erode behind the breaker. In the absence of a stable area, construct appropriate energy-dissipating devices at the end of the breaker.
- d. Slope breakers may extend slightly (about 4 feet) beyond the edge of the construction right-of-way to effectively drain water off the disturbed area. Where slope breakers extend beyond the edge of the construction right-of-way, they are subject to compliance with all applicable survey requirements.

C. SOIL COMPACTION MITIGATION

- 1. Test topsoil and subsoil for compaction at regular intervals in agricultural and residential areas disturbed by construction activities. Conduct tests on the same soil type under similar moisture conditions in undisturbed areas to approximate preconstruction conditions. Use penetrometers or other appropriate devices to conduct tests.
- 2. Plow severely compacted agricultural areas with a paraplow or other deep tillage implement. In areas where topsoil has been segregated, plow the subsoil before replacing the segregated topsoil.

If subsequent construction and cleanup activities result in further compaction, conduct additional tilling.

3. Perform appropriate soil compaction mitigation in severely compacted residential areas.

#### D. REVEGETATION

##### 1. General

- a. The project sponsor is responsible for ensuring successful revegetation of soils disturbed by project-related activities, except as noted in section V.D.1.b.
- b. Restore all turf, ornamental shrubs, and specialized landscaping in accordance with the landowner's request, or compensate the landowner. Restoration work must be performed by personnel familiar with local horticultural and turf establishment practices.

##### 2. Soil Additives

Fertilize and add soil pH modifiers in accordance with written recommendations obtained from the local soil conservation authority, land management agencies, or landowner. Incorporate recommended soil pH modifier and fertilizer into the top 2 inches of soil as soon as practicable after application.

##### 3. Seeding Requirements

- a. Prepare a seedbed in disturbed areas to a depth of 3 to 4 inches using appropriate equipment to provide a firm seedbed. When hydroseeding, scarify the seedbed to facilitate lodging and germination of seed.
- b. Seed disturbed areas in accordance with written recommendations for seed mixes, rates, and dates obtained from the local soil conservation authority or the request of the landowner or land management agency. Seeding is not required in cultivated croplands unless requested by the landowner.
- c. Perform seeding of permanent vegetation within the recommended seeding dates. If seeding cannot be done within those dates, use appropriate temporary erosion control measures discussed in section IV.F and perform seeding of permanent vegetation at the beginning of the next recommended seeding season. Dormant seeding or temporary

seeding of annual species may also be used, if necessary, to establish cover, as approved by the Environmental Inspector. Lawns may be seeded on a schedule established with the landowner.

- d. In the absence of written recommendations from the local soil conservation authorities, seed all disturbed soils within 6 working days of final grading, weather and soil conditions permitting, subject to the specifications in section V.D.3.a through V.D.3.c.
- e. Base seeding rates on Pure Live Seed. Use seed within 12 months of seed testing.
- f. Treat legume seed with an inoculant specific to the species using the manufacturer's recommended rate of inoculant appropriate for the seeding method (broadcast, drill, or hydro).
- g. In the absence of written recommendations from the local soil conservation authorities, landowner, or land managing agency to the contrary, a seed drill equipped with a cultipacker is preferred for seed application.

Broadcast or hydroseeding can be used in lieu of drilling at double the recommended seeding rates. Where seed is broadcast, firm the seedbed with a cultipacker or roller after seeding. In rocky soils or where site conditions may limit the effectiveness of this equipment, other alternatives may be appropriate (e.g., use of a chain drag) to lightly cover seed after application, as approved by the Environmental Inspector.

## VI. OFF-ROAD VEHICLE CONTROL

To each owner or manager of forested lands, offer to install and maintain measures to control unauthorized vehicle access to the right-of-way. These measures may include:

- A. signs;
- B. fences with locking gates;
- C. slash and timber barriers, pipe barriers, or a line of boulders across the right-of-way; and
- D. conifers or other appropriate trees or shrubs across the right-of-way.

## VII. POST-CONSTRUCTION ACTIVITIES AND REPORTING

### A. MONITORING AND MAINTENANCE

1. Conduct follow-up inspections of all disturbed areas, as necessary, to determine the success of revegetation and address landowner concerns. At a minimum, conduct inspections after the first and second growing seasons.
2. Revegetation in non-agricultural areas shall be considered successful if upon visual survey the density and cover of non-nuisance vegetation are similar in density and cover to adjacent undisturbed lands. In agricultural areas, revegetation shall be considered successful when upon visual survey, crop growth and vigor are similar to adjacent undisturbed portions of the same field, unless the easement agreement specifies otherwise.

Continue revegetation efforts until revegetation is successful.

3. Monitor and correct problems with drainage and irrigation systems resulting from pipeline construction in agricultural areas until restoration is successful.
4. Restoration shall be considered successful if the right-of-way surface condition is similar to adjacent undisturbed lands, construction debris is removed (unless otherwise approved by the landowner or land managing agency per section V.A.6), revegetation is successful, and proper drainage has been restored.
5. Routine vegetation mowing or clearing over the full width of the permanent right-of-way in uplands shall not be done more frequently than every 3 years. However, to facilitate periodic corrosion/leak surveys, a corridor not exceeding 10 feet in width centered on the pipeline may be cleared at a frequency necessary to maintain the 10-foot corridor in an herbaceous state. In no case shall routine vegetation mowing or clearing occur during the migratory bird nesting season between April 15 and August 1 of any year unless specifically approved in writing by the responsible land management agency or the U.S. Fish and Wildlife Service.
6. Efforts to control unauthorized off-road vehicle use, in cooperation with the landowner, shall continue throughout the life of the project. Maintain signs, gates, and permanent access roads as necessary.

## B. REPORTING

1. The project sponsor shall maintain records that identify by milepost:
  - a. method of application, application rate, and type of fertilizer, pH modifying agent, seed, and mulch used;
  - b. acreage treated;
  - c. dates of backfilling and seeding;
  - d. names of landowners requesting special seeding treatment and a description of the follow-up actions;
  - e. the location of any subsurface drainage repairs or improvements made during restoration; and
  - f. any problem areas and how they were addressed.
  
2. The project sponsor shall file with the Secretary quarterly activity reports documenting the results of follow-up inspections required by section VII.A.1; any problem areas, including those identified by the landowner; and corrective actions taken for at least 2 years following construction.

The requirement to file quarterly activity reports with the Secretary does not apply to projects constructed under the automatic authorization, prior notice, or advanced notice provisions in the FERC's regulations.



Table 7.4-1 Requested Alternative Measures to the 2013 FERC Plan for GPX Terminal Construction and Operation				
Alternative No.	Applicable FERC Plan Section	FERC 2013 Plan Sub-Section	Golden Pass' Requested Alternative Measure ( <u>Requested Alternative Measure Language Underlined</u> )	Justification
1	III. Preconstruction Planning	<p><i>F. Agency Coordination</i></p> <p>1. Obtain written recommendations from the local soil conservation authorities or land management agencies regarding permanent erosion control and revegetation specifications.</p>	<p>Golden Pass is requesting an alternative measure to allow for stabilization of permanently converted areas that does not include active revegetation. All areas, including construction laydown areas, will be graveled or otherwise stabilized to prevent erosion. These areas will remain in a graveled state following construction. The permanent footprint within the operational boundary of the GPX Terminal will be gravel or asphalt. The levee constructed around the terminal is anticipated to be stabilized with rock and seeded as required to assure structural integrity.</p> <p><i>F. Agency Coordination</i></p> <p>1. <u>In areas that are not permanently converted to impervious surface (e.g., gravel, asphalt) and the storm protection levee, GPP will request recommendations from the local soil conservation authorities or land management agencies regarding permanent erosion control and revegetation specifications.</u></p>	<p>Permanently stabilizing the construction laydown areas will prevent erosion post-construction. Golden Pass will perform work related to the requested alternative measure in a conscientious manner and in accordance with applicable Federal and State environmental laws.</p>
2	IV. Installation	<p><i>F. Temporary Erosion Control</i></p> <p>4. <i>Mulch</i></p> <p>a. Apply mulch on all slopes (except in cultivated cropland) concurrent with or immediately after seeding, where necessary to stabilize the soil surface and to reduce wind and water erosion. Spread mulch uniformly over the area to cover at least 75 percent of the ground</p>	<p>Golden Pass is requesting an alternative measure to allow for stabilization of permanently converted areas that does not include active mulching and seeding.</p> <p><i>F. Temporary Erosion Control</i></p> <p>4. <i>Mulch</i></p> <p>a. <u>In areas that are not permanently converted to impervious surface (e.g., gravel, asphalt,) and the storm protection</u></p>	<p>All areas, including construction laydown areas, will be graveled or otherwise stabilized to prevent erosion. These areas will remain in a graveled state following construction. The permanent footprint within the operational boundary of</p>

Table 7.4-1 Requested Alternative Measures to the 2013 FERC Plan for GPX Terminal Construction and Operation				
Alternative No.	Applicable FERC Plan Section	FERC 2013 Plan Sub-Section	Golden Pass' Requested Alternative Measure (Requested Alternative Measure Language <u>Underlined</u> )	Justification
		surface at a rate of 2 tons/acre of straw or its equivalent, unless the local soil conservation authority, landowner, or land managing agency approves otherwise in writing.	<u>levee</u> , apply mulch on all slopes concurrent with or immediately after seeding, where necessary to stabilize the soil surface and to reduce wind and water erosion. Spread mulch uniformly over the area to cover at least 75 percent of the ground surface.	the GPX Terminal will be gravel or asphalt. The levee constructed around the terminal is anticipated to be stabilized with rock and seeded as required to assure structural integrity. Permanently stabilizing the construction laydown areas will prevent erosion post-construction.  Golden Pass will perform work related to the requested alternative measure in a conscientious manner and in accordance with applicable Federal and State environmental laws.
3	V. Restoration	<i>D. Revegetation</i> <i>2. Soil Additives</i> Fertilize and add soil pH modifiers in accordance with written recommendations obtained from the local soil conservation authority, land management agencies, or landowner. Incorporate recommended soil pH modifier and fertilizer into the top 2 inches of soil as soon as practicable after application.	Golden Pass is requesting an alternative measure to allow for stabilization of permanently converted areas that does not include soil additives. <i>D. Revegetation</i> <i>2. Soil Additives</i> <u>In areas that are not permanently converted to impervious surface (e.g., gravel, asphalt) and the storm protection levee, fertilize and add soil pH modifiers in accordance with recommendations obtained from the local soil conservation authority, land management agencies, or landowner. Incorporate</u>	All areas, including construction laydown areas, will be graveled or otherwise stabilized to prevent erosion. These areas will remain in a graveled state following construction. The permanent footprint within the operational boundary of the GPX Terminal will be gravel or asphalt. The levee constructed around the terminal is anticipated to be stabilized with rock and

Table 7.4-1 Requested Alternative Measures to the 2013 FERC Plan for GPX Terminal Construction and Operation				
Alternative No.	Applicable FERC Plan Section	FERC 2013 Plan Sub-Section	Golden Pass' Requested Alternative Measure (Requested Alternative Measure Language <u>Underlined</u> )	Justification
			recommended soil pH modifier and fertilizer into the top 2 inches of soil as soon as practicable after application.	seeded as required to assure structural integrity. Permanently stabilizing the construction laydown areas will prevent erosion post-construction. Golden Pass will perform work related to the requested alternative measure in a conscientious manner and in accordance with applicable Federal and State environmental laws.
4	V. Restoration	<p><i>D. Revegetation</i></p> <p><b>3. Seeding Requirements</b></p> <p>a. Prepare a seedbed in disturbed areas to a depth of 3 to 4 inches using appropriate equipment to provide a firm seedbed. When hydroseeding, scarify the seedbed to facilitate lodging and germination of seed.</p> <p>b. Seed disturbed areas in accordance with written recommendations for seed mixes, rates, and dates obtained from the local soil conservation authority or the request of the landowner or land management agency. Seeding is not required in cultivated croplands unless requested by the landowner.</p> <p>c. Perform seeding of permanent vegetation within the recommended seeding dates. If seeding cannot be done within those dates,</p>	<p>Golden Pass is requesting an alternative measure to allow for stabilization of permanently converted areas that does not include seeding.</p> <p><i>D. Revegetation</i></p> <p><b>3. Seeding Requirements</b></p> <p><u>In areas that are not permanently converted to impervious surface (e.g., gravel, asphalt) and the storm protection levee:</u></p> <p>a. Prepare a seedbed in disturbed areas to a depth of 3 to 4 inches using appropriate equipment to provide a firm seedbed. When hydroseeding, scarify the seedbed to facilitate lodging and germination of seed.</p> <p>b. Seed disturbed areas in accordance with written recommendations for seed mixes, rates, and dates obtained from the local soil</p>	<p>All areas, including construction laydown areas, will be graveled or otherwise stabilized to prevent erosion. These areas will remain in a graveled state following construction. The permanent footprint within the operational boundary of the GPX Terminal will be gravel or asphalt. The levee constructed around the terminal is anticipated to be stabilized with rock and seeded as required to assure structural integrity. Permanently stabilizing the construction laydown areas will prevent erosion post-</p>

Table 7.4-1 Requested Alternative Measures to the 2013 FERC Plan for GPX Terminal Construction and Operation				
Alternative No.	Applicable FERC Plan Section	FERC 2013 Plan Sub-Section	Golden Pass' Requested Alternative Measure <u>(Requested Alternative Measure Language Underlined)</u>	Justification
		<p>use appropriate temporary erosion control measures discussed in section IV.F and perform seeding of permanent vegetation at the beginning of the next recommended seeding season. Dormant seeding or temporary seeding of annual species may also be used, if necessary, to establish cover, as approved by the Environmental Inspector. Lawns may be seeded on a schedule established with the landowner.</p> <p>d. In the absence of written recommendations from the local soil conservation authorities, seed all disturbed soils within 6 working days of final grading, weather and soil conditions permitting, subject to the specifications in section V.D.3.a through V.D.3.c.</p> <p>e. Base seeding rates on Pure Live Seed. Use seed within 12 months of seed testing.</p> <p>f. Treat legume seed with an inoculant specific to the species using the manufacturer's recommended rate of inoculant appropriate for the seeding method (broadcast, drill, or hydro).</p> <p>g. In the absence of written recommendations from the local soil conservation authorities, landowner, or land managing agency to the contrary, a seed drill equipped with a cultipacker is preferred for seed application.</p> <p>Broadcast or hydroseeding can be used in</p>	<p>conservation authority or the request of the landowner or land management agency. Seeding is not required in cultivated croplands unless requested by the landowner.</p> <p>c. Perform seeding of permanent vegetation within the recommended seeding dates. If seeding cannot be done within those dates, use appropriate temporary erosion control measures discussed in section IV.F and perform seeding of permanent vegetation at the beginning of the next recommended seeding season. Dormant seeding or temporary seeding of annual species may also be used, if necessary, to establish cover, as approved by the Environmental Inspector. Lawns may be seeded on a schedule established with the landowner.</p> <p>d. In the absence of written recommendations from the local soil conservation authorities, seed all disturbed soils within 6 working days of final grading, weather and soil conditions permitting, subject to the specifications in section V.D.3.a through V.D.3.c.</p> <p>e. Base seeding rates on Pure Live Seed. Use seed within 12 months of seed testing.</p> <p>f. Treat legume seed with an inoculant specific to the species using the manufacturer's recommended rate of inoculant appropriate for the seeding method (broadcast, drill, or hydro).</p> <p>g. In the absence of written recommendations from the local soil conservation authorities,</p>	<p>construction.</p> <p>Golden Pass will perform work related to the requested alternative measure in a conscientious manner and in accordance with applicable Federal and State environmental laws.</p>

Table 7.4-1 Requested Alternative Measures to the 2013 FERC Plan for GPX Terminal Construction and Operation				
Alternative No.	Applicable FERC Plan Section	FERC 2013 Plan Sub-Section	Golden Pass' Requested Alternative Measure <u>(Requested Alternative Measure Language Underlined)</u>	Justification
		lieu of drilling at double the recommended seeding rates. Where seed is broadcast, firm the seedbed with a cultipacker or roller after seeding. In rocky soils or where site conditions may limit the effectiveness of this equipment, other alternatives may be appropriate (e.g., use of a chain drag) to lightly cover seed after application, as approved by the Environmental Inspector.	landowner, or land managing agency to the contrary, a seed drill equipped with a cultipacker is preferred for seed application.  Broadcast or hydroseeding can be used in lieu of drilling at double the recommended seeding rates. Where seed is broadcast, firm the seedbed with a cultipacker or roller after seeding. In rocky soils or where site conditions may limit the effectiveness of this equipment, other alternatives may be appropriate (e.g., use of a chain drag) to lightly cover seed after application, as approved by the Environmental Inspector.	
5	VII. Post-Construction Activities and Reporting	<p><i>B. Reporting</i></p> <p>1. The project sponsor shall maintain records that identify by milepost:</p> <p>a. method of application, application rate, and type of fertilizer, pH modifying agent, seed, and mulch used;</p> <p>b. acreage treated;</p> <p>c. dates of backfilling and seeding;</p> <p>d. names of landowners requesting special seeding treatment and a description of the follow-up actions;</p> <p>e. the location of any subsurface drainage repairs or improvements made during restoration; and</p> <p>f. any problem areas and how they were</p>	<p>Golden Pass is requesting an alternative measure from the required reporting. The intent is to allow for stabilization of permanently areas that does not include seeding, mulching and soil additives.</p> <p><i>B. Reporting</i></p> <p>1. <u>In areas that are not permanently converted to impervious surface (e.g., gravel, asphalt) and the storm protection levee, the project sponsor shall maintain records that identify by milepost:</u></p> <p>a. method of application, application rate, and type of fertilizer, pH modifying agent, seed, and mulch used;</p> <p>b. acreage treated;</p> <p>c. dates of backfilling and seeding;</p> <p>d. names of landowners requesting special</p>	<p>All areas, including construction laydown areas, will be graveled or otherwise stabilized to prevent erosion. These areas will remain in a graveled state following construction. The permanent footprint within the operational boundary of the GPX Terminal will be gravel or asphalt. The levee constructed around the terminal is anticipated to be stabilized with rock and seeded as required to assure structural integrity. Permanently stabilizing the construction laydown areas will prevent erosion post-</p>

Table 7.4-1 Requested Alternative Measures to the 2013 FERC Plan for GPX Terminal Construction and Operation				
Alternative No.	Applicable FERC Plan Section	FERC 2013 Plan Sub-Section	Golden Pass' Requested Alternative Measure (Requested Alternative Measure Language <u>Underlined</u> )	Justification
		addressed.	seeding treatment and a description of the follow-up actions; e. the location of any subsurface drainage repairs or improvements made during restoration; and f. any problem areas and how they were addressed.	construction. Golden Pass will perform work related to the requested alternative measure in a conscientious manner and in accordance with applicable Federal and State environmental laws.

Table 7.4-2 Requested Alternative Measures to the 2013 FERC Plan for GPX Pipeline Construction and Operation				
Alternative No.	Applicable FERC Plan Section	FERC 2013 Plan Sub-Section	Golden Pass' Requested Alternative Measure ( <u>Requested Alternative Measure Language Underlined</u> )	Justification
6	VII. Post-Construction Activities and Reporting	<p><i>A. Monitoring and Maintenance 5.</i></p> <p>Routine vegetation mowing or clearing over the full width of the permanent right-of-way in uplands shall not be done more frequently than every 3 years. However, to facilitate periodic corrosion/leak surveys, a corridor not exceeding 10 feet in width centered on the pipeline may be cleared at a frequency necessary to maintain the 10-foot corridor in an herbaceous state. In no case shall routine vegetation mowing or clearing occur during the migratory bird nesting season between April 15 and August 1 of any year unless specifically approved in writing by the responsible land management agency or the U.S. Fish and Wildlife Service.</p>	<p>Golden Pass is requesting an alternative measure to allow annual mowing of the full width of the permanent ROW, outside of the HDD area.</p> <p><i>A. Monitoring and Maintenance 5.</i></p> <p>Routine vegetation mowing or clearing over the full width of the permanent right-of-way in uplands shall not be done more frequently than <u>once a year</u>. However, to facilitate periodic corrosion/leak surveys, a corridor not exceeding 10 feet in width centered on the pipeline may be cleared at a frequency necessary to maintain the 10-foot corridor in an herbaceous state. In no case shall routine vegetation mowing or clearing occur during the migratory bird nesting season between April 15 and August 1 of any year unless specifically approved in writing by the responsible land management agency or the U.S. Fish and Wildlife Service.</p>	<p>Based on observations of the existing GP Pipeline ROW, due to the extended growing season in east Texas, annual mowing would facilitate annual inspection and maintenance of the pipeline facilities.</p> <p>Golden Pass will perform work related to the requested alternative measure in a conscientious manner and in accordance with applicable Federal and State environmental laws.</p>

**APPENDIX H**  
**FERC's Wetland and Waterbody Construction and Mitigation Procedures**  
**(FERC's Procedures)**



**PUBLIC**

Golden Pass Products, LLC (GPP) and  
Golden Pass Pipeline, LLC (GPPL)  
Golden Pass Products LNG Export Project (GPX Project)  
FERC Docket Nos. CP14-517-000 and CP14-518-000  
USACE Permit Application SWG-2004-02118  
Response to USACE January 26, 2015 Information Request

---

**FERC's 2013 WETLAND AND WATERBODY CONSTRUCTION AND MITIGATION  
PROCEDURES**

---



**Federal Energy  
Regulatory  
Commission**

**Office of  
Energy Projects**

**May 2013**

---

# **WETLAND AND WATERBODY CONSTRUCTION AND MITIGATION PROCEDURES**

Washington, DC 20426

MAY 2013 VERSION

# WETLAND AND WATERBODY CONSTRUCTION AND MITIGATION PROCEDURES

## TABLE OF CONTENTS

I.	<u>APPLICABILITY</u> .....	1
II.	<u>PRECONSTRUCTION FILING</u> .....	2
III.	<u>ENVIRONMENTAL INSPECTORS</u> .....	3
IV.	<u>PRECONSTRUCTION PLANNING</u> .....	3
V.	<u>WATERBODY CROSSINGS</u> .....	5
	A. NOTIFICATION PROCEDURES AND PERMITS .....	5
	B. INSTALLATION .....	5
	1. Time Window for Construction .....	5
	2. Extra Work Areas .....	5
	3. General Crossing Procedures .....	6
	4. Spoil Pile Placement and Control .....	7
	5. Equipment Bridges .....	7
	6. Dry-Ditch Crossing Methods .....	8
	7. Crossings of Minor Waterbodies .....	9
	8. Crossings of Intermediate Waterbodies .....	10
	9. Crossings of Major Waterbodies .....	10
	10. Temporary Erosion and Sediment Control .....	10
	11. Trench Dewatering .....	11
	C. RESTORATION .....	11
	D. POST-CONSTRUCTION MAINTENANCE .....	12
VI.	<u>WETLAND CROSSINGS</u> .....	13
	A. GENERAL .....	13
	B. INSTALLATION .....	14
	1. Extra Work Areas and Access Roads .....	14
	2. Crossing Procedures .....	15
	3. Temporary Sediment Control .....	16
	4. Trench Dewatering .....	17
	C. RESTORATION .....	17
	D. POST-CONSTRUCTION MAINTENANCE AND REPORTING .....	18
VII.	<u>HYDROSTATIC TESTING</u> .....	19
	A. NOTIFICATION PROCEDURES AND PERMITS .....	19
	B. GENERAL .....	19
	C. INTAKE SOURCE AND RATE .....	19
	D. DISCHARGE LOCATION, METHOD, AND RATE .....	20

**WETLAND AND WATERBODY  
CONSTRUCTION AND MITIGATION PROCEDURES (PROCEDURES)**

I. APPLICABILITY

- A. The intent of these Procedures is to assist project sponsors by identifying baseline mitigation measures for minimizing the extent and duration of project-related disturbance on wetlands and waterbodies. Project sponsors shall specify in their applications for a new FERC authorization, and in prior notice and advance notice filings, any individual measures in these Procedures they consider unnecessary, technically infeasible, or unsuitable due to local conditions and fully describe any alternative measures they would use. Project sponsors shall also explain how those alternative measures would achieve a comparable level of mitigation.

Once a project is authorized, project sponsors can request further changes as variances to the measures in these Procedures (or the applicant's approved procedures). The Director of the Office of Energy Projects (Director) will consider approval of variances upon the project sponsor's written request, if the Director agrees that a variance:

1. provides equal or better environmental protection;
2. is necessary because a portion of these Procedures is infeasible or unworkable based on project-specific conditions; or
3. is specifically required in writing by another federal, state, or Native American land management agency for the portion of the project on its land or under its jurisdiction.

Sponsors of projects planned for construction under the automatic authorization provisions in the FERC's regulations must receive written approval for any variances in advance of construction.

Project-related impacts on non-wetland areas are addressed in the staff's Upland Erosion Control, Revegetation, and Maintenance Plan (Plan).

## B. DEFINITIONS

1. “Waterbody” includes any natural or artificial stream, river, or drainage with perceptible flow at the time of crossing, and other permanent waterbodies such as ponds and lakes:
  - a. “minor waterbody” includes all waterbodies less than or equal to 10 feet wide at the water’s edge at the time of crossing;
  - b. “intermediate waterbody” includes all waterbodies greater than 10 feet wide but less than or equal to 100 feet wide at the water’s edge at the time of crossing; and
  - c. “major waterbody” includes all waterbodies greater than 100 feet wide at the water’s edge at the time of crossing.
2. “Wetland” includes any area that is not in actively cultivated or rotated cropland and that satisfies the requirements of the current federal methodology for identifying and delineating wetlands.

## II. PRECONSTRUCTION FILING

- A. The following information must be filed with the Secretary of the FERC (Secretary) prior to the beginning of construction, for the review and written approval by the Director:
  1. site-specific justifications for extra work areas that would be closer than 50 feet from a waterbody or wetland; and
  2. site-specific justifications for the use of a construction right-of-way greater than 75-feet-wide in wetlands.
- B. The following information must be filed with the Secretary prior to the beginning of construction. These filing requirements do not apply to projects constructed under the automatic authorization provisions in the FERC’s regulations:
  1. Spill Prevention and Response Procedures specified in section IV.A;
  2. a schedule identifying when trenching or blasting will occur within each waterbody greater than 10 feet wide, within any designated coldwater fishery, and within any waterbody identified as habitat for federally-listed threatened or endangered species. The project sponsor will revise the schedule as necessary to provide FERC staff at least 14 days advance notice. Changes within this last 14-day period must provide for at least 48 hours advance notice;

3. plans for horizontal directional drills (HDD) under wetlands or waterbodies, specified in section V.B.6.d;
4. site-specific plans for major waterbody crossings, described in section V.B.9;
5. a wetland delineation report as described in section VI.A.1, if applicable; and
6. the hydrostatic testing information specified in section VII.B.3.

### III. ENVIRONMENTAL INSPECTORS

- A. At least one Environmental Inspector having knowledge of the wetland and waterbody conditions in the project area is required for each construction spread. The number and experience of Environmental Inspectors assigned to each construction spread shall be appropriate for the length of the construction spread and the number/significance of resources affected.
- B. The Environmental Inspector's responsibilities are outlined in the Upland Erosion Control, Revegetation, and Maintenance Plan (Plan).

### IV. PRECONSTRUCTION PLANNING

- A. The project sponsor shall develop project-specific Spill Prevention and Response Procedures that meet applicable requirements of state and federal agencies. A copy must be filed with the Secretary prior to construction and made available in the field on each construction spread. This filing requirement does not apply to projects constructed under the automatic authorization provisions in the FERC's regulations.
  1. It shall be the responsibility of the project sponsor and its contractors to structure their operations in a manner that reduces the risk of spills or the accidental exposure of fuels or hazardous materials to waterbodies or wetlands. The project sponsor and its contractors must, at a minimum, ensure that:
    - a. all employees handling fuels and other hazardous materials are properly trained;
    - b. all equipment is in good operating order and inspected on a regular basis;
    - c. fuel trucks transporting fuel to on-site equipment travel only on approved access roads;
    - d. all equipment is parked overnight and/or fueled at least 100 feet from a waterbody or in an upland area at least 100 feet from a wetland boundary. These activities can occur closer only if the Environmental Inspector determines that there is no reasonable alternative, and the

project sponsor and its contractors have taken appropriate steps (including secondary containment structures) to prevent spills and provide for prompt cleanup in the event of a spill;

- e. hazardous materials, including chemicals, fuels, and lubricating oils, are not stored within 100 feet of a wetland, waterbody, or designated municipal watershed area, unless the location is designated for such use by an appropriate governmental authority. This applies to storage of these materials and does not apply to normal operation or use of equipment in these areas;
  - f. concrete coating activities are not performed within 100 feet of a wetland or waterbody boundary, unless the location is an existing industrial site designated for such use. These activities can occur closer only if the Environmental Inspector determines that there is no reasonable alternative, and the project sponsor and its contractors have taken appropriate steps (including secondary containment structures) to prevent spills and provide for prompt cleanup in the event of a spill;
  - g. pumps operating within 100 feet of a waterbody or wetland boundary utilize appropriate secondary containment systems to prevent spills; and
  - h. bulk storage of hazardous materials, including chemicals, fuels, and lubricating oils have appropriate secondary containment systems to prevent spills.
2. The project sponsor and its contractors must structure their operations in a manner that provides for the prompt and effective cleanup of spills of fuel and other hazardous materials. At a minimum, the project sponsor and its contractors must:
- a. ensure that each construction crew (including cleanup crews) has on hand sufficient supplies of absorbent and barrier materials to allow the rapid containment and recovery of spilled materials and knows the procedure for reporting spills and unanticipated discoveries of contamination;
  - b. ensure that each construction crew has on hand sufficient tools and material to stop leaks;
  - c. know the contact names and telephone numbers for all local, state, and federal agencies (including, if necessary, the U. S. Coast Guard and the National Response Center) that must be notified of a spill; and

- d. follow the requirements of those agencies in cleaning up the spill, in excavating and disposing of soils or other materials contaminated by a spill, and in collecting and disposing of waste generated during spill cleanup.

## B. AGENCY COORDINATION

The project sponsor must coordinate with the appropriate local, state, and federal agencies as outlined in these Procedures and in the FERC's Orders.

## V. WATERBODY CROSSINGS

### A. NOTIFICATION PROCEDURES AND PERMITS

1. Apply to the U.S. Army Corps of Engineers (COE), or its delegated agency, for the appropriate wetland and waterbody crossing permits.
2. Provide written notification to authorities responsible for potable surface water supply intakes located within 3 miles downstream of the crossing at least 1 week before beginning work in the waterbody, or as otherwise specified by that authority.
3. Apply for state-issued waterbody crossing permits and obtain individual or generic section 401 water quality certification or waiver.
4. Notify appropriate federal and state authorities at least 48 hours before beginning trenching or blasting within the waterbody, or as specified in applicable permits.

### B. INSTALLATION

1. Time Window for Construction

Unless expressly permitted or further restricted by the appropriate federal or state agency in writing on a site-specific basis, instream work, except that required to install or remove equipment bridges, must occur during the following time windows:

- a. coldwater fisheries - June 1 through September 30; and
- b. coolwater and warmwater fisheries - June 1 through November 30.

2. Extra Work Areas

- a. Locate all extra work areas (such as staging areas and additional spoil storage areas) at least 50 feet away from water's edge, except where



the adjacent upland consists of cultivated or rotated cropland or other disturbed land.

- b. The project sponsor shall file with the Secretary for review and written approval by the Director, site-specific justification for each extra work area with a less than 50-foot setback from the water's edge, except where the adjacent upland consists of cultivated or rotated cropland or other disturbed land. The justification must specify the conditions that will not permit a 50-foot setback and measures to ensure the waterbody is adequately protected.
- c. Limit the size of extra work areas to the minimum needed to construct the waterbody crossing.

### 3. General Crossing Procedures

- a. Comply with the COE, or its delegated agency, permit terms and conditions.
- b. Construct crossings as close to perpendicular to the axis of the waterbody channel as engineering and routing conditions permit.
- c. Where pipelines parallel a waterbody, maintain at least 15 feet of undisturbed vegetation between the waterbody (and any adjacent wetland) and the construction right-of-way, except where maintaining this offset will result in greater environmental impact.
- d. Where waterbodies meander or have multiple channels, route the pipeline to minimize the number of waterbody crossings.
- e. Maintain adequate waterbody flow rates to protect aquatic life, and prevent the interruption of existing downstream uses.
- f. Waterbody buffers (e.g., extra work area setbacks, refueling restrictions) must be clearly marked in the field with signs and/or highly visible flagging until construction-related ground disturbing activities are complete.
- g. Crossing of waterbodies when they are dry or frozen and not flowing may proceed using standard upland construction techniques in accordance with the Plan, provided that the Environmental Inspector verifies that water is unlikely to flow between initial disturbance and final stabilization of the feature. In the event of perceptible flow, the project sponsor must comply with all applicable Procedure requirements for "waterbodies" as defined in section I.B.1.

4. Spoil Pile Placement and Control

- a. All spoil from minor and intermediate waterbody crossings, and upland spoil from major waterbody crossings, must be placed in the construction right-of-way at least 10 feet from the water's edge or in additional extra work areas as described in section V.B.2.
- b. Use sediment barriers to prevent the flow of spoil or silt-laden water into any waterbody.

5. Equipment Bridges

- a. Only clearing equipment and equipment necessary for installation of equipment bridges may cross waterbodies prior to bridge installation. Limit the number of such crossings of each waterbody to one per piece of clearing equipment.
- b. Construct and maintain equipment bridges to allow unrestricted flow and to prevent soil from entering the waterbody. Examples of such bridges include:
  - (1) equipment pads and culvert(s);
  - (2) equipment pads or railroad car bridges without culverts;
  - (3) clean rock fill and culvert(s); and
  - (4) flexi-float or portable bridges.

Additional options for equipment bridges may be utilized that achieve the performance objectives noted above. Do not use soil to construct or stabilize equipment bridges.

- c. Design and maintain each equipment bridge to withstand and pass the highest flow expected to occur while the bridge is in place. Align culverts to prevent bank erosion or streambed scour. If necessary, install energy dissipating devices downstream of the culverts.
- d. Design and maintain equipment bridges to prevent soil from entering the waterbody.
- e. Remove temporary equipment bridges as soon as practicable after permanent seeding.
- f. If there will be more than 1 month between final cleanup and the beginning of permanent seeding and reasonable alternative access to the right-of-way is available, remove temporary equipment bridges as soon as practicable after final cleanup.

- g. Obtain any necessary approval from the COE, or the appropriate state agency for permanent bridges.

6. Dry-Ditch Crossing Methods

- a. Unless approved otherwise by the appropriate federal or state agency, install the pipeline using one of the dry-ditch methods outlined below for crossings of waterbodies up to 30 feet wide (at the water's edge at the time of construction) that are state-designated as either coldwater or significant coolwater or warmwater fisheries, or federally-designated as critical habitat.

- b. Dam and Pump

- (1) The dam-and-pump method may be used without prior approval for crossings of waterbodies where pumps can adequately transfer streamflow volumes around the work area, and there are no concerns about sensitive species passage.
- (2) Implementation of the dam-and-pump crossing method must meet the following performance criteria:
  - (i) use sufficient pumps, including on-site backup pumps, to maintain downstream flows;
  - (ii) construct dams with materials that prevent sediment and other pollutants from entering the waterbody (e.g., sandbags or clean gravel with plastic liner);
  - (iii) screen pump intakes to minimize entrainment of fish;
  - (iv) prevent streambed scour at pump discharge; and
  - (v) continuously monitor the dam and pumps to ensure proper operation throughout the waterbody crossing.

- c. Flume Crossing

The flume crossing method requires implementation of the following steps:

- (1) install flume pipe after blasting (if necessary), but before any trenching;
- (2) use sand bag or sand bag and plastic sheeting diversion structure or equivalent to develop an effective seal and to divert stream flow through the flume pipe (some modifications to the stream bottom may be required to achieve an effective seal);

- (3) properly align flume pipe(s) to prevent bank erosion and streambed scour;
- (4) do not remove flume pipe during trenching, pipelaying, or backfilling activities, or initial streambed restoration efforts; and
- (5) remove all flume pipes and dams that are not also part of the equipment bridge as soon as final cleanup of the stream bed and bank is complete.

d. Horizontal Directional Drill

For each waterbody or wetland that would be crossed using the HDD method, file with the Secretary for the review and written approval by the Director, a plan that includes:

- (1) site-specific construction diagrams that show the location of mud pits, pipe assembly areas, and all areas to be disturbed or cleared for construction;
- (2) justification that disturbed areas are limited to the minimum needed to construct the crossing;
- (3) identification of any aboveground disturbance or clearing between the HDD entry and exit workspaces during construction;
- (4) a description of how an inadvertent release of drilling mud would be contained and cleaned up; and
- (5) a contingency plan for crossing the waterbody or wetland in the event the HDD is unsuccessful and how the abandoned drill hole would be sealed, if necessary.

The requirement to file HDD plans does not apply to projects constructed under the automatic authorization provisions in the FERC's regulations.

7. Crossings of Minor Waterbodies

Where a dry-ditch crossing is not required, minor waterbodies may be crossed using the open-cut crossing method, with the following restrictions:

- a. except for blasting and other rock breaking measures, complete instream construction activities (including trenching, pipe installation, backfill, and restoration of the streambed contours) within 24 hours.

Streambanks and unconsolidated streambeds may require additional restoration after this period;

- b. limit use of equipment operating in the waterbody to that needed to construct the crossing; and
- c. equipment bridges are not required at minor waterbodies that do not have a state-designated fishery classification or protected status (e.g., agricultural or intermittent drainage ditches). However, if an equipment bridge is used it must be constructed as described in section V.B.5.

#### 8. Crossings of Intermediate Waterbodies

Where a dry-ditch crossing is not required, intermediate waterbodies may be crossed using the open-cut crossing method, with the following restrictions:

- a. complete instream construction activities (not including blasting and other rock breaking measures) within 48 hours, unless site-specific conditions make completion within 48 hours infeasible;
- b. limit use of equipment operating in the waterbody to that needed to construct the crossing; and
- c. all other construction equipment must cross on an equipment bridge as specified in section V.B.5.

#### 9. Crossings of Major Waterbodies

Before construction, the project sponsor shall file with the Secretary for the review and written approval by the Director a detailed, site-specific construction plan and scaled drawings identifying all areas to be disturbed by construction for each major waterbody crossing (the scaled drawings are not required for any offshore portions of pipeline projects). This plan must be developed in consultation with the appropriate state and federal agencies and shall include extra work areas, spoil storage areas, sediment control structures, etc., as well as mitigation for navigational issues. The requirement to file major waterbody crossing plans does not apply to projects constructed under the automatic authorization provisions of the FERC's regulations.

The Environmental Inspector may adjust the final placement of the erosion and sediment control structures in the field to maximize effectiveness.

#### 10. Temporary Erosion and Sediment Control

Install sediment barriers (as defined in section IV.F.3.a of the Plan) immediately after initial disturbance of the waterbody or adjacent upland.

Sediment barriers must be properly maintained throughout construction and reinstalled as necessary (such as after backfilling of the trench) until replaced by permanent erosion controls or restoration of adjacent upland areas is complete. Temporary erosion and sediment control measures are addressed in more detail in the Plan; however, the following specific measures must be implemented at stream crossings:

- a. install sediment barriers across the entire construction right-of-way at all waterbody crossings, where necessary to prevent the flow of sediments into the waterbody. Removable sediment barriers (or driveable berms) must be installed across the travel lane. These removable sediment barriers can be removed during the construction day, but must be re-installed after construction has stopped for the day and/or when heavy precipitation is imminent;
- b. where waterbodies are adjacent to the construction right-of-way and the right-of-way slopes toward the waterbody, install sediment barriers along the edge of the construction right-of-way as necessary to contain spoil within the construction right-of-way and prevent sediment flow into the waterbody; and
- c. use temporary trench plugs at all waterbody crossings, as necessary, to prevent diversion of water into upland portions of the pipeline trench and to keep any accumulated trench water out of the waterbody.

#### 11. Trench Dewatering

Dewater the trench (either on or off the construction right-of-way) in a manner that does not cause erosion and does not result in silt-laden water flowing into any waterbody. Remove the dewatering structures as soon as practicable after the completion of dewatering activities.

### C. RESTORATION

1. Use clean gravel or native cobbles for the upper 1 foot of trench backfill in all waterbodies that contain coldwater fisheries.
2. For open-cut crossings, stabilize waterbody banks and install temporary sediment barriers within 24 hours of completing instream construction activities. For dry-ditch crossings, complete streambed and bank stabilization before returning flow to the waterbody channel.
3. Return all waterbody banks to preconstruction contours or to a stable angle of repose as approved by the Environmental Inspector.
4. Install erosion control fabric or a functional equivalent on waterbody banks at the time of final bank recontouring. Do not use synthetic monofilament

mesh/netted erosion control materials in areas designated as sensitive wildlife habitat unless the product is specifically designed to minimize harm to wildlife. Anchor erosion control fabric with staples or other appropriate devices.

5. Application of riprap for bank stabilization must comply with COE, or its delegated agency, permit terms and conditions.
6. Unless otherwise specified by state permit, limit the use of riprap to areas where flow conditions preclude effective vegetative stabilization techniques such as seeding and erosion control fabric.
7. Revegetate disturbed riparian areas with native species of conservation grasses, legumes, and woody species, similar in density to adjacent undisturbed lands.
8. Install a permanent slope breaker across the construction right-of-way at the base of slopes greater than 5 percent that are less than 50 feet from the waterbody, or as needed to prevent sediment transport into the waterbody. In addition, install sediment barriers as outlined in the Plan.

In some areas, with the approval of the Environmental Inspector, an earthen berm may be suitable as a sediment barrier adjacent to the waterbody.

9. Sections V.C.3 through V.C.7 above also apply to those perennial or intermittent streams not flowing at the time of construction.

#### D. POST-CONSTRUCTION MAINTENANCE

1. Limit routine vegetation mowing or clearing adjacent to waterbodies to allow a riparian strip at least 25 feet wide, as measured from the waterbody's mean high water mark, to permanently revegetate with native plant species across the entire construction right-of-way. However, to facilitate periodic corrosion/leak surveys, a corridor centered on the pipeline and up to 10 feet wide may be cleared at a frequency necessary to maintain the 10-foot corridor in an herbaceous state. In addition, trees that are located within 15 feet of the pipeline that have roots that could compromise the integrity of the pipeline coating may be cut and removed from the permanent right-of-way. Do not conduct any routine vegetation mowing or clearing in riparian areas that are between HDD entry and exit points.
2. Do not use herbicides or pesticides in or within 100 feet of a waterbody except as allowed by the appropriate land management or state agency.
3. Time of year restrictions specified in section VII.A.5 of the Plan (April 15 – August 1 of any year) apply to routine mowing and clearing of riparian areas.

## VI. WETLAND CROSSINGS

### A. GENERAL

1. The project sponsor shall conduct a wetland delineation using the current federal methodology and file a wetland delineation report with the Secretary before construction. The requirement to file a wetland delineation report does not apply to projects constructed under the automatic authorization provisions in the FERC's regulations.

This report shall identify:

- a. by milepost all wetlands that would be affected;
- b. the National Wetlands Inventory (NWI) classification for each wetland;
- c. the crossing length of each wetland in feet; and
- d. the area of permanent and temporary disturbance that would occur in each wetland by NWI classification type.

The requirements outlined in this section do not apply to wetlands in actively cultivated or rotated cropland. Standard upland protective measures, including workspace and topsoiling requirements, apply to these agricultural wetlands.

2. Route the pipeline to avoid wetland areas to the maximum extent possible. If a wetland cannot be avoided or crossed by following an existing right-of-way, route the new pipeline in a manner that minimizes disturbance to wetlands. Where looping an existing pipeline, overlap the existing pipeline right-of-way with the new construction right-of-way. In addition, locate the loop line no more than 25 feet away from the existing pipeline unless site-specific constraints would adversely affect the stability of the existing pipeline.
3. Limit the width of the construction right-of-way to 75 feet or less. Prior written approval of the Director is required where topographic conditions or soil limitations require that the construction right-of-way width within the boundaries of a federally delineated wetland be expanded beyond 75 feet. Early in the planning process the project sponsor is encouraged to identify site-specific areas where excessively wide trenches could occur and/or where spoil piles could be difficult to maintain because existing soils lack adequate unconfined compressive strength.
4. Wetland boundaries and buffers must be clearly marked in the field with signs and/or highly visible flagging until construction-related ground disturbing activities are complete.



5. Implement the measures of sections V and VI in the event a waterbody crossing is located within or adjacent to a wetland crossing. If all measures of sections V and VI cannot be met, the project sponsor must file with the Secretary a site-specific crossing plan for review and written approval by the Director before construction. This crossing plan shall address at a minimum:
  - a. spoil control;
  - b. equipment bridges;
  - c. restoration of waterbody banks and wetland hydrology;
  - d. timing of the waterbody crossing;
  - e. method of crossing; and
  - f. size and location of all extra work areas.
6. Do not locate aboveground facilities in any wetland, except where the location of such facilities outside of wetlands would prohibit compliance with U.S. Department of Transportation regulations.

## B. INSTALLATION

1. Extra Work Areas and Access Roads
  - a. Locate all extra work areas (such as staging areas and additional spoil storage areas) at least 50 feet away from wetland boundaries, except where the adjacent upland consists of cultivated or rotated cropland or other disturbed land.
  - b. The project sponsor shall file with the Secretary for review and written approval by the Director, site-specific justification for each extra work area with a less than 50-foot setback from wetland boundaries, except where adjacent upland consists of cultivated or rotated cropland or other disturbed land. The justification must specify the site-specific conditions that will not permit a 50-foot setback and measures to ensure the wetland is adequately protected.
  - c. The construction right-of-way may be used for access when the wetland soil is firm enough to avoid rutting or the construction right-of-way has been appropriately stabilized to avoid rutting (e.g., with timber riprap, prefabricated equipment mats, or terra mats).

In wetlands that cannot be appropriately stabilized, all construction equipment other than that needed to install the wetland crossing shall

use access roads located in upland areas. Where access roads in upland areas do not provide reasonable access, limit all other construction equipment to one pass through the wetland using the construction right-of-way.

- d. The only access roads, other than the construction right-of-way, that can be used in wetlands are those existing roads that can be used with no modifications or improvements, other than routine repair, and no impact on the wetland.

## 2. Crossing Procedures

- a. Comply with COE, or its delegated agency, permit terms and conditions.
- b. Assemble the pipeline in an upland area unless the wetland is dry enough to adequately support skids and pipe.
- c. Use “push-pull” or “float” techniques to place the pipe in the trench where water and other site conditions allow.
- d. Minimize the length of time that topsoil is segregated and the trench is open. Do not trench the wetland until the pipeline is assembled and ready for lowering in.
- e. Limit construction equipment operating in wetland areas to that needed to clear the construction right-of-way, dig the trench, fabricate and install the pipeline, backfill the trench, and restore the construction right-of-way.
- f. Cut vegetation just above ground level, leaving existing root systems in place, and remove it from the wetland for disposal.

The project sponsor can burn woody debris in wetlands, if approved by the COE and in accordance with state and local regulations, ensuring that all remaining woody debris is removed for disposal.

- g. Limit pulling of tree stumps and grading activities to directly over the trenchline. Do not grade or remove stumps or root systems from the rest of the construction right-of-way in wetlands unless the Chief Inspector and Environmental Inspector determine that safety-related construction constraints require grading or the removal of tree stumps from under the working side of the construction right-of-way.
- h. Segregate the top 1 foot of topsoil from the area disturbed by trenching, except in areas where standing water is present or soils are

saturated. Immediately after backfilling is complete, restore the segregated topsoil to its original location.

- i. Do not use rock, soil imported from outside the wetland, tree stumps, or brush riprap to support equipment on the construction right-of-way.
- j. If standing water or saturated soils are present, or if construction equipment causes ruts or mixing of the topsoil and subsoil in wetlands, use low-ground-weight construction equipment, or operate normal equipment on timber riprap, prefabricated equipment mats, or terra mats.
- k. Remove all project-related material used to support equipment on the construction right-of-way upon completion of construction.

### 3. Temporary Sediment Control

Install sediment barriers (as defined in section IV.F.3.a of the Plan) immediately after initial disturbance of the wetland or adjacent upland. Sediment barriers must be properly maintained throughout construction and reinstalled as necessary (such as after backfilling of the trench). Except as noted below in section VI.B.3.c, maintain sediment barriers until replaced by permanent erosion controls or restoration of adjacent upland areas is complete. Temporary erosion and sediment control measures are addressed in more detail in the Plan.

- a. Install sediment barriers across the entire construction right-of-way immediately upslope of the wetland boundary at all wetland crossings where necessary to prevent sediment flow into the wetland.
- b. Where wetlands are adjacent to the construction right-of-way and the right-of-way slopes toward the wetland, install sediment barriers along the edge of the construction right-of-way as necessary to contain spoil within the construction right-of-way and prevent sediment flow into the wetland.
- c. Install sediment barriers along the edge of the construction right-of-way as necessary to contain spoil and sediment within the construction right-of-way through wetlands. Remove these sediment barriers during right-of-way cleanup.

4. Trench Dewatering

Dewater the trench (either on or off the construction right-of-way) in a manner that does not cause erosion and does not result in silt-laden water flowing into any wetland. Remove the dewatering structures as soon as practicable after the completion of dewatering activities.

C. RESTORATION

1. Where the pipeline trench may drain a wetland, construct trench breakers at the wetland boundaries and/or seal the trench bottom as necessary to maintain the original wetland hydrology.
2. Restore pre-construction wetland contours to maintain the original wetland hydrology.
3. For each wetland crossed, install a trench breaker at the base of slopes near the boundary between the wetland and adjacent upland areas. Install a permanent slope breaker across the construction right-of-way at the base of slopes greater than 5 percent where the base of the slope is less than 50 feet from the wetland, or as needed to prevent sediment transport into the wetland. In addition, install sediment barriers as outlined in the Plan. In some areas, with the approval of the Environmental Inspector, an earthen berm may be suitable as a sediment barrier adjacent to the wetland.
4. Do not use fertilizer, lime, or mulch unless required in writing by the appropriate federal or state agency.
5. Consult with the appropriate federal or state agencies to develop a project-specific wetland restoration plan. The restoration plan shall include measures for re-establishing herbaceous and/or woody species, controlling the invasion and spread of invasive species and noxious weeds (e.g., purple loosestrife and phragmites), and monitoring the success of the revegetation and weed control efforts. Provide this plan to the FERC staff upon request.
6. Until a project-specific wetland restoration plan is developed and/or implemented, temporarily revegetate the construction right-of-way with annual ryegrass at a rate of 40 pounds/acre (unless standing water is present).
7. Ensure that all disturbed areas successfully revegetate with wetland herbaceous and/or woody plant species.
8. Remove temporary sediment barriers located at the boundary between wetland and adjacent upland areas after revegetation and stabilization of adjacent upland areas are judged to be successful as specified in section VII.A.4 of the Plan.

#### D. POST-CONSTRUCTION MAINTENANCE AND REPORTING

1. Do not conduct routine vegetation mowing or clearing over the full width of the permanent right-of-way in wetlands. However, to facilitate periodic corrosion/leak surveys, a corridor centered on the pipeline and up to 10 feet wide may be cleared at a frequency necessary to maintain the 10-foot corridor in an herbaceous state. In addition, trees within 15 feet of the pipeline with roots that could compromise the integrity of pipeline coating may be selectively cut and removed from the permanent right-of-way. Do not conduct any routine vegetation mowing or clearing in wetlands that are between HDD entry and exit points.
2. Do not use herbicides or pesticides in or within 100 feet of a wetland, except as allowed by the appropriate federal or state agency.
3. Time of year restrictions specified in section VII.A.5 of the Plan (April 15 – August 1 of any year) apply to routine mowing and clearing of wetland areas.
4. Monitor and record the success of wetland revegetation annually until wetland revegetation is successful.
5. Wetland revegetation shall be considered successful if all of the following criteria are satisfied:
  - a. the affected wetland satisfies the current federal definition for a wetland (i.e., soils, hydrology, and vegetation);
  - b. vegetation is at least 80 percent of either the cover documented for the wetland prior to construction, or at least 80 percent of the cover in adjacent wetland areas that were not disturbed by construction;
  - c. if natural rather than active revegetation was used, the plant species composition is consistent with early successional wetland plant communities in the affected ecoregion; and
  - d. invasive species and noxious weeds are absent, unless they are abundant in adjacent areas that were not disturbed by construction.
6. Within 3 years after construction, file a report with the Secretary identifying the status of the wetland revegetation efforts and documenting success as defined in section VI.D.5, above. The requirement to file wetland restoration reports with the Secretary does not apply to projects constructed under the automatic authorization, prior notice, or advance notice provisions in the FERC's regulations.

For any wetland where revegetation is not successful at the end of 3 years after construction, develop and implement (in consultation with a

professional wetland ecologist) a remedial revegetation plan to actively revegetate wetlands. Continue revegetation efforts and file a report annually documenting progress in these wetlands until wetland revegetation is successful.

## VII. HYDROSTATIC TESTING

### A. NOTIFICATION PROCEDURES AND PERMITS

1. Apply for state-issued water withdrawal permits, as required.
2. Apply for National Pollutant Discharge Elimination System (NPDES) or state-issued discharge permits, as required.
3. Notify appropriate state agencies of intent to use specific sources at least 48 hours before testing activities unless they waive this requirement in writing.

### B. GENERAL

1. Perform 100 percent radiographic inspection of all pipeline section welds or hydrotest the pipeline sections, before installation under waterbodies or wetlands.
2. If pumps used for hydrostatic testing are within 100 feet of any waterbody or wetland, address secondary containment and refueling of these pumps in the project's Spill Prevention and Response Procedures.
3. The project sponsor shall file with the Secretary before construction a list identifying the location of all waterbodies proposed for use as a hydrostatic test water source or discharge location. This filing requirement does not apply to projects constructed under the automatic authorization provisions of the FERC's regulations.

### C. INTAKE SOURCE AND RATE

1. Screen the intake hose to minimize the potential for entrainment of fish.
2. Do not use state-designated exceptional value waters, waterbodies which provide habitat for federally listed threatened or endangered species, or waterbodies designated as public water supplies, unless appropriate federal, state, and/or local permitting agencies grant written permission.
3. Maintain adequate flow rates to protect aquatic life, provide for all waterbody uses, and provide for downstream withdrawals of water by existing users.
4. Locate hydrostatic test manifolds outside wetlands and riparian areas to the maximum extent practicable.

D. DISCHARGE LOCATION, METHOD, AND RATE

1. Regulate discharge rate, use energy dissipation device(s), and install sediment barriers, as necessary, to prevent erosion, streambed scour, suspension of sediments, or excessive streamflow.
2. Do not discharge into state-designated exceptional value waters, waterbodies which provide habitat for federally listed threatened or endangered species, or waterbodies designated as public water supplies, unless appropriate federal, state, and local permitting agencies grant written permission.

**PUBLIC**

Golden Pass Products, LLC (GPP) and  
Golden Pass Pipeline, LLC (GPPL)  
Golden Pass Products LNG Export Project (GPX Project)  
FERC Docket Nos. CP14-517-000 and CP14-518-000  
USACE Permit Application SWG-2004-02118  
Response to USACE January 26, 2015 Information Request

---

## **GOLDEN PASS' REQUESTED VARIANCES TO FERC'S 2013 PROCEDURES**

Requested alternative measures to FERC's 2013 Procedures for GPX Terminal and GPX Pipeline aboveground facilities construction and operation in Jefferson and Orange counties, Texas, are listed in **Tables 2.5-1** and **2.5-3**, respectively. These tables were included in Resource Report No. 2 of the Final Environmental Report filed to FERC Docket Nos. CP14-517-000 and CP14-518-000 on July 7, 2014, and have been updated based upon additional correspondence with FERC. FERC's acceptance of the requested alternative measures is pending.

Although alternative measures are being requested to the FERC Procedures, Golden Pass recognizes that any filling of wetlands or dredging activities can occur only if authorized under Section 404 of the CWA (regardless of the requested alternative measure).

---



**Table 2.5-1**

**Requested Alternative Measures from the 2013 FERC Procedures for GPX Terminal Construction and Operation**

Variance No.	Applicable FERC Procedures Section	FERC 2013 Procedures Sub-Section	Golden Pass' Requested Alternative Measure ( <u>Alternative Measure Language Underlined</u> )	Justification
1	VI. Preconstruction Planning	A. 1. <i>d. All equipment is parked overnight and/or fueled at least 100 feet from a waterbody or in an upland area at least 100 feet from a wetland boundary. These activities can occur closer only if the Environmental Inspector determines that there is no reasonable alternative, and the project sponsor and its contractors have taken appropriate steps (including secondary containment structures) to prevent spills and provide for prompt cleanup in the event of a spill.</i>	Golden Pass is requesting an alternative measure to allow for controlled fueling of construction barges in the SNWW at the MOF: <u>A. 1.</u> <u>d. For water-based equipment (e.g., tugs and barge mounted equipment) fueling procedures will follow applicable USCG protocols.</u>	No fueling or overnight parking will occur within 100 feet of undisturbed wetlands or waterbodies. However, activities in the MOF will require activity within the 100 foot buffer of the SNWW and adjacent wetlands. Barges in the MOF will take prudent precautions to ensure no spills will occur to the SNWW during docking and fueling including secondary containment.  Golden Pass will perform work related to the requested alternative measure in a conscientious manner and in accordance with applicable Federal and State environmental laws.

**Table 2.5-1**

**Requested Alternative Measures from the 2013 FERC Procedures for GPX Terminal Construction and Operation**

Variance No.	Applicable FERC Procedures Section	FERC 2013 Procedures Sub-Section	Golden Pass' Requested Alternative Measure ( <u>Alternative Measure Language Underlined</u> )	Justification
2	VI. Preconstruction Planning	A. 1. <i>e. Hazardous materials, including chemicals, fuels, and lubricating oils, are not stored within 100 feet of a wetland, waterbody, or designated municipal watershed area, unless the location is designated for such use by an appropriate governmental authority. This applies to storage of these materials and does not apply to normal operation or use of equipment in these areas</i>	Golden Pass is requesting an alternative measure to allow for fuel barge(s) to be docked at the MOF: <u>A. 1. e. Hazardous materials, including chemicals, fuels and lubricating oils, stored within 100 feet of a wetland or waterbody will be evaluated by the Environmental Inspector to ensure that contractors have taken appropriate steps (including secondary containment structures) to prevent spills and provide for prompt cleanup in the event of a spill. Due to the extra protection it affords, EI inspection will not be necessary for materials stored within the storm protection levee once completed. Additionally, for water-based equipment (e.g., tugs and barge mounted equipment) fueling procedures will follow applicable USCG protocols.</u>	Onshore storage of hazardous materials will be within depicted staging and laydown areas where wetlands will be permanently filled. No hazardous materials will be stored within 100 feet of undisturbed wetlands or waterbodies. However, activities in the MOF will require activity within the 100 foot buffer of the SNWW and adjacent wetlands. Barges in the MOF will use precautions to ensure no spills will occur to the SNWW including secondary containment.  Golden Pass will perform work related to the requested alternative measure in a conscientious manner and in accordance with applicable Federal and State environmental laws.

**Table 2.5-1**

**Requested Alternative Measures from the 2013 FERC Procedures for GPX Terminal Construction and Operation**

Variance No.	Applicable FERC Procedures Section	FERC 2013 Procedures Sub-Section	Golden Pass' Requested Alternative Measure ( <u>Alternative Measure Language Underlined</u> )	Justification
3	V. Waterbody Crossings	<i>B. Installation 1. Unless expressly permitted or further restricted by the appropriate federal or state agency in writing on a site-specific basis, instream work, except that required to install or remove equipment bridges, must occur during the following time windows: b. coolwater and warmwater fisheries - June 1 through November 30</i>	Golden Pass is requesting an alternative measure to allow for year-round use of the SNWW during GPX Terminal construction and operation, including required dredging (new and maintenance, as required): <u>B. Installation 1. Activity in the SNWW and PUB areas on the GPLNG Terminal will be permitted to occur year-round.</u>	Year-round access is required to minimize the timeframe of active construction and related potential effects. The SNWW is a heavily industrialized waterway with vessel traffic and activity common year-round. The area is also routinely dredged to maintain channel depth. The SNWW and PUB in the GPX Project area does not represent unique or critical habitat for any species.  Golden Pass will perform work related to the requested alternative measure in a conscientious manner and in accordance with applicable Federal and State environmental laws.

**Table 2.5-1**

**Requested Alternative Measures from the 2013 FERC Procedures for GPX Terminal Construction and Operation**

Variance No.	Applicable FERC Procedures Section	FERC 2013 Procedures Sub-Section	Golden Pass' Requested Alternative Measure ( <u>Alternative Measure Language Underlined</u> )	Justification
4	V. Waterbody Crossings	<p><i>B. Installation 2. Extra Work Areas</i></p> <p><i>a. Locate all extra work areas (such as staging areas and additional spoil storage areas) at least 50 feet away from water's edge, except where the adjacent upland consists of cultivated or rotated cropland or other disturbed land</i></p> <p><i>b. The project sponsor shall file with the Secretary for review and written approval by the Director, site-specific justification for each extra work area with a less than 50-foot setback from the water's edge, except where the adjacent upland consists of cultivated or rotated cropland or other disturbed land. The justification must specify the conditions that will not permit a 50-foot setback and measures to ensure the waterbody is adequately protected</i></p>	<p>Golden Pass is requesting an alternative measure at the GPX Terminal to allow for construction laydown areas closer than 50 feet to wetlands and the SNWW:</p> <p><u>B. Installation 2. Extra Work Areas</u></p> <p><u>a. Extra work areas (such as staging areas and additional spoil storage areas) associated with the GPX Terminal will be permitted within 50 feet from the SNWW.</u></p>	<p>Extra work areas for the GPX Terminal are proposed to be created through the filling of adjacent wetlands to the proposed liquefaction facilities. The area surrounding the GPX Terminal is comprised of wetland habitat without suitable upland areas for staging and storage to construct the GPX Project.</p> <p>The proximity of laydown areas cannot be avoided due to co-location and integration with the existing GP Terminal facilities. Golden Pass will use precautions to ensure no spills will occur to the SNWW including secondary containment.</p> <p>Golden Pass will perform work related to the requested alternative measure in a conscientious manner and in accordance with applicable Federal and State environmental laws.</p>

**Table 2.5-1**

**Requested Alternative Measures from the 2013 FERC Procedures for GPX Terminal Construction and Operation**

Variance No.	Applicable FERC Procedures Section	FERC 2013 Procedures Sub-Section	Golden Pass' Requested Alternative Measure ( <u>Alternative Measure Language Underlined</u> )	Justification
5	V. Waterbody Crossings	<i>C. Restoration Return all waterbody banks to preconstruction contours or to a stable angle of repose as approved by the Environmental Inspector</i>	Golden Pass is requesting an alternative measure to allow for the MOF to remain in place for intermittent use following construction: <u>C. Restoration Armored shoreline protection structures will be maintained throughout construction and GPX Terminal operations.</u>	The MOF will be designed with shoreline armoring to avoid and minimize shoreline erosion. In addition, the MOF will be closely monitored and maintained in good working order post-construction.  Golden Pass will perform work related to the requested alternative measure in a conscientious manner and in accordance with applicable Federal and State environmental laws.
6	V. Waterbody Crossings	<i>D. Post-construction Maintenance 2. Do not use herbicides or pesticides in or within 100 feet of a waterbody except as allowed by the appropriate land management or state agency</i>	Golden Pass is requesting an alternative measure to allow the controlled use of herbicides or pesticides on the GPX Terminal site adjacent to the SNWW: <u>D. Post-construction Maintenance 2. The use herbicides or pesticides on filled areas in or within 100 feet of a waterbody will be in accordance with industry best management practices and in a conscientious manner and in accordance with applicable Federal and State environmental laws.</u>	These areas are inside of the storm protection levee.  Golden Pass will perform work related to the requested alternative measure in a conscientious manner and in accordance with applicable Federal and State environmental laws.

**Table 2.5-1**

**Requested Alternative Measures from the 2013 FERC Procedures for GPX Terminal Construction and Operation**

Variance No.	Applicable FERC Procedures Section	FERC 2013 Procedures Sub-Section	Golden Pass' Requested Alternative Measure <u>(Alternative Measure Language Underlined)</u>	Justification
7	VI. Wetland Crossings	<p><i>A. General 6. Do not locate aboveground facilities in any wetland, except where the location of such facilities outside of wetlands would prohibit compliance with U.S. Department of Transportation regulations</i></p>	<p>Golden Pass is requesting an alternative measure to allow for siting of the GPX Terminal facilities within wetland areas:  <u>A. General 6. The footprint of aboveground facilities will include wetlands that are being converted to industrial filled areas.</u></p>	<p>Siting of the liquefaction facilities makes use of the existing GPLNG Terminal facilities to minimize the overall footprint of the GPX Terminal. It is not feasible to site the facilities outside of wetlands due to limited upland areas surround the GPLNG Terminal. The GPX Terminal siting was chosen in part based on compliance with U.S. Department of Transportation regulation. Golden Pass will perform work related to the requested alternative measure in a conscientious manner and in accordance with applicable Federal and State environmental laws.</p>
8	VI. Wetland Crossings	<p><i>B. Installation 1. Extra Work Areas and Access Roads a. Locate all extra work areas (such as staging areas and additional spoil storage areas) at least 50 feet away from wetland boundaries, except where the adjacent upland consists of cultivated or rotated cropland or other disturbed land</i></p>	<p>Golden Pass is requesting an alternative measure for siting of extra work areas within 50 feet of wetlands in order to construct the GPX Terminal facilities:  <u>B. Installation 1. Extra Work Areas and Access Roads a. The footprint of extra work areas and access roads will occur in wetlands immediately adjacent to the GPX Terminal.</u></p>	<p>Siting of the liquefaction facilities makes use of the existing GPLNG Terminal facilities to minimize the overall footprint of the GPX Terminal. The areas surrounding the GPLNG Terminal are comprised of large coastal marsh wetland complexes. Therefore, the extra workspace will be located with wetlands. However, Golden Pass will take proactive and prudent measures to ensure its effects are limited to only those areas necessary to safely construct the GPX Terminal. Golden Pass will perform work related to the requested alternative measure in a conscientious manner and in accordance with applicable Federal and State environmental laws.</p>

**Table 2.5-1**

**Requested Alternative Measures from the 2013 FERC Procedures for GPX Terminal Construction and Operation**

Variance No.	Applicable FERC Procedures Section	FERC 2013 Procedures Sub-Section	Golden Pass' Requested Alternative Measure <u>(Alternative Measure Language Underlined)</u>	Justification
9	VI. Wetland Crossings	<p><i>B. Installation 1. Extra Work Areas and Access Roads</i></p> <p><i>d. The only access roads, other than the construction right-of-way, that can be used in wetlands are those existing roads that can be used with no modifications or improvements, other than routine repair, and no impact on the wetland</i></p>	<p>Golden Pass is requesting an alternative measure to allow for improvement of the existing access road that transverses the large PEM wetland between the SH 87 and the existing GPLNG Terminal. The road will require widening and improvements for construction of the GPX Terminal:</p> <p><u>B. Installation 1. Extra Work Areas and Access Roads</u></p> <p><u>d. There will be one primary access road used during construction from SH 87. The current access road and associated borrow ditches will be widened to nominally 100 feet. In addition, the GPX Terminal primary access road will be altered to provide access to new administration building.</u></p>	<p>The existing roadway to the GPX Terminal will not support the required construction vehicle traffic without improvement. Golden Pass will take prudent measures to ensure that any effects are limited to only those areas necessary to safely construct the GPX Terminal and for necessary operations post-construction.</p> <p>Golden Pass will perform work related to the requested alternative measure in a conscientious manner and in accordance with applicable Federal and State environmental laws.</p>
10	VI. Wetland Crossings	<p><i>B. Installation 4. Trench Dewatering</i></p> <p><i>Dewater the trench (either on or off the construction right-of-way) in a manner that does not cause erosion and does not result in silt-laden water flowing into any wetland. Remove the dewatering structures as soon as practicable after the completion of dewatering activities</i></p>	<p>Golden Pass is requesting an alternative measure to allow for controlled trench dewatering discharge into the adjacent wetland area:</p> <p><u>B. Installation 4. Trench Dewatering</u></p> <p><u>In compliance with the Clean Water Act and applicable regulations, dewatering to wetland areas will be evaluated by the Environmental Inspector to ensure that contractors have taken appropriate steps that do not cause erosion and result in silt-laden water flowing .</u></p> <p><u>Removal of dewatering structures is to occur as soon as practicable after the completion of dewatering activities.</u></p>	<p>Related dewatering at the GPX Terminal construction area will require discharge into vegetated wetlands as adequate uplands for discharging do not exist on the GPLNG Terminal property. Golden Pass will implement other BMPs (i.e., dewatering structure, baffles) to ensure that the discharge does not cause erosion or otherwise impair water quality in the wetland complex.</p> <p>Golden Pass will perform work related to the requested alternative measure in a conscientious manner and in accordance with applicable Federal and State environmental laws.</p>



**Table 2.5-1**

**Requested Alternative Measures from the 2013 FERC Procedures for GPX Terminal Construction and Operation**

Variance No.	Applicable FERC Procedures Section	FERC 2013 Procedures Sub-Section	Golden Pass' Requested Alternative Measure ( <u>Alternative Measure Language Underlined</u> )	Justification
11	VI. Wetland Crossings	<i>C. Restoration 2. Restore pre-construction wetland contours to maintain the original wetland hydrology</i>	Golden Pass is requesting an alternative measure from returning wetlands in the construction area to pre-construction contours: <u>C. Restoration 2. Altered contours in previous, but subsequently filled, wetland areas will be permitted to remain following construction. Pre-construction contours will not be returned in permanently stabilized areas</u>	The wetlands within both the permanent facilities and construction laydown areas are requested to be permanently filled. As the construction laydown area will need to be utilized for 5 years and require a substantial amount of fill to build a safe working area, restoration after construction will not be feasible. All wetlands within the permanent and construction workspace will be mitigated assuming permanent loss in coordination with the USACE and other applicable resource agencies and in accordance with the applicable provisions of the Clean Water Act.  Golden Pass will perform work related to the requested alternative measure in a conscientious manner and in accordance with applicable Federal and State environmental laws.



**Table 2.5-1**

**Requested Alternative Measures from the 2013 FERC Procedures for GPX Terminal Construction and Operation**

Variance No.	Applicable FERC Procedures Section	FERC 2013 Procedures Sub-Section	Golden Pass' Requested Alternative Measure ( <u>Alternative Measure Language Underlined</u> )	Justification
12	VI. Wetland Crossings	<i>C. Restoration 6. Until a project-specific wetland restoration plan is developed and/or implemented, temporarily revegetate the construction right-of-way with annual ryegrass at a rate of 40 pounds/acre (unless standing water is present)</i>	Golden Pass is requesting an alternative measure from seeding the pre-construction wetland areas at the GPX Terminal site: <u>C. Restoration 6.</u> <u>A project-specific wetland mitigation plan is to be developed and/or implemented prior to GPX Project operations.</u>	As the construction laydown area will need to be utilized for 5 years and require a substantial amount of fill to build a safe and secure working area, restoration of wetland areas after construction will not be feasible. All wetlands within the permanent and construction workspace will be mitigated assuming permanent loss in coordination with the USACE and other applicable resource agencies.  Golden Pass will perform work related to the requested alternative measure in a conscientious manner and in accordance with applicable Federal and State environmental laws.

**Table 2.5-1**

**Requested Alternative Measures from the 2013 FERC Procedures for GPX Terminal Construction and Operation**

Variance No.	Applicable FERC Procedures Section	FERC 2013 Procedures Sub-Section	Golden Pass' Requested Alternative Measure ( <u>Alternative Measure Language Underlined</u> )	Justification
13	VI. Wetland Crossings	<p><i>D. Post-Construction Maintenance and Reporting 1.</i>                      Do not conduct routine vegetation mowing or clearing over the full width of the permanent right-of-way in wetlands. However, to facilitate periodic corrosion/leak surveys, a corridor centered on the pipeline and up to 10 feet wide may be cleared at a frequency necessary to maintain the 10-foot corridor in an herbaceous state. In addition, trees within 15 feet of the pipeline with roots that could compromise the integrity of pipeline coating may be selectively cut and removed from the permanent right-of-way. Do not conduct any routine vegetation mowing or clearing in wetlands that are between HDD entry and exit points</p>	<p>Golden Pass is requesting an alternative measure to allow for controlled routine mowing of wetland areas around the security fencing and other areas for safety reasons:  <u>D. Post-Construction Maintenance and Reporting 1.</u>  <u>Routine vegetation maintenance will be conducted around security fences and within property boundaries and other areas required to maintain safe operations.</u></p>	<p>Operations would intend to mow around the perimeter fence and other areas required for safe GPX Terminal operation on a routine basis. Due to the long growing season in along the Gulf Coast, an increased frequency of mowing will allow for proper inspection and maintenance of the fencing and corollary site areas. Subsequent clarification provided in response to August 28, 2014 data request: Golden Pass intends to mow inside and outside the GPX Terminal fence. A distance up to 25 feet outside of the perimeter fence will be required to be mowed for security purposes including monitoring of the perimeter of the terminal per USCG regulations. Golden Pass will perform work related to the requested alternative measure in a conscientious manner and in accordance with applicable Federal and State environmental laws.</p>

**Table 2.5-1**

**Requested Alternative Measures from the 2013 FERC Procedures for GPX Terminal Construction and Operation**

Variance No.	Applicable FERC Procedures Section	FERC 2013 Procedures Sub-Section	Golden Pass' Requested Alternative Measure ( <u>Alternative Measure Language Underlined</u> )	Justification
14	VI. Wetland Crossings	<p><i>D. Post-Construction Maintenance and Reporting 2.</i>  <i>Do not use herbicides or pesticides in or within 100 feet of a wetland, except as allowed by the appropriate federal or state agency</i></p>	<p>Golden Pass is requesting an alternative measure to allow the controlled use of herbicide or pesticides on the GPX Terminal site adjacent to wetlands:  <u>D. Post-construction Maintenance and Reporting 2.</u>  <u>The use herbicides or pesticides on filled areas in or within 100 feet of a wetland will be in accordance with industry best management practices and in a conscientious manner and in accordance with applicable Federal and State environmental laws.</u></p>	<p>As the construction laydown area will need to be utilized for 5 years and require a substantial amount of fill to build a safe working area, restoration of wetland areas after construction will not be feasible. However, these areas will be adjacent to wetlands and will need to be maintained. Golden Pass will perform work related to the requested alternative measure in a conscientious manner and in accordance with applicable Federal and State environmental laws.</p>

Table 2.5-3 Requested Alternative Measures from the 2013 FERC Procedures for GPX Pipeline Aboveground Facility Construction and Operation					
Variance No.	MP <sup>1</sup>	Applicable FERC Procedures Section	FERC 2013 Procedures Sub-Section	Golden Pass' Requested Alternative Measures (Alternative Measure Language Underlined)	Justification
18	1 33 66	V. Waterbody Crossings	<i>D. Post-construction Maintenance 2. Do not use herbicides or pesticides in or within 100 feet of a waterbody except as allowed by the appropriate land management or state agency</i>	Golden Pass is requesting an alternative measure to allow the controlled use of herbicides or pesticides on the Compressor Station sites adjacent to impoundments/ponds: <u>D. Post-construction Maintenance 2.</u> <u>The controlled use herbicides or pesticides in or within 100 feet of a waterbody will be in accordance with industry best management practices</u>	Golden Pass will perform work related to the requested alternative measure in a conscientious manner and in accordance with applicable Federal and State environmental laws.
19	1 33 66	VI. Wetland Crossings	<i>A. General 6. Do not locate aboveground facilities in any wetland, except where the location of such facilities outside of wetlands would prohibit compliance with U.S. Department of Transportation regulations</i>	Golden Pass is requesting an alternative measure to allow for siting of compressor stations within wetland areas: <u>A. General 6.</u> <u>The footprint of above-ground facilities in any wetland is to be restricted to the extent practicable for compliance with U.S. Department of Transportation, Pipeline and Hazardous Materials Safety Administration, and other applicable regulations</u>	Efforts were made to avoid or minimize effects to wetlands at all compressor station locations; however, due to the need to co-locate with existing natural gas infrastructure: <ul style="list-style-type: none"> <li>• Similar to the GPX Terminal, siting of the MP 1 Compressor Station will require the filling of wetlands</li> <li>• Minimal effects to PEM wetlands will occur at MP 33 and 66 Compressor Stations for siting the facility. Measures were taken to avoid PFO wetlands and minimize permanent effects</li> </ul> Golden Pass will perform work related to the requested alternative measure in a conscientious manner and in accordance with applicable Federal and State environmental laws.

Table 2.5-3 Requested Alternative Measures from the 2013 FERC Procedures for GPX Pipeline Aboveground Facility Construction and Operation					
Variance No.	MP <sup>1</sup>	Applicable FERC Procedures Section	FERC 2013 Procedures Sub-Section	Golden Pass' Requested Alternative Measures (Alternative Measure Language Underlined)	Justification
20	1 33 63 66	VI. Wetland Crossings	<p><i>B. Installation 1. Extra Work Areas and Access Roads</i></p> <p><i>a. Locate all extra work areas (such as staging areas and additional spoil storage areas) at least 50 feet away from wetland boundaries, except where the adjacent upland consists of cultivated or rotated cropland or other disturbed land</i></p>	<p>Golden Pass is requesting an alternative measure for siting of extra work areas within 50 feet of wetlands in order to construct the compressor stations and interconnects:</p> <p><u>B. Installation 1. Extra Work Areas and Access Roads</u></p> <p><u>a. The footprint of extra work areas and access roads in wetland is to be restricted to the extent practicable for safe construction of the GPX Project facilities:</u></p> <ul style="list-style-type: none"> <li>• MP 1 Compressor Station: 2 ATWSs within Wetland W-014 (BES, 2013a)</li> <li>• MP 33 Compressor Station: 1 ATWS within Wetlands W-21 and W-23 (BES, 2013b)</li> <li>• MP 63 Interconnect: 1 ATWS which overlaps Wetlands W-181, W-182 and W-183 (BES, 2013b)</li> <li>• MP 66 Compressor Station: 1 ATWS within 50 feet of Wetlands W-093 and W-094 (BES, 2013b).</li> </ul> <p>See Appendix 2H – Supplemental Figures</p>	<p>Efforts were made to avoid or minimize effects to wetlands at all aboveground facility locations; however, due to the need to co-locate with existing natural gas infrastructure, some extra work areas were necessary within 50 feet:</p> <ul style="list-style-type: none"> <li>• Extra work areas for the MP 1 Compressor Station are proposed to be created through the filling of adjacent wetlands to the proposed liquefaction facilities. The area surrounding the GPX Terminal is comprised of wetland habitat without suitable upland areas for staging and storage to construct the GPX Project. Erosion control BMPs will be installed for wetland protection.</li> <li>• The permanent footprint of the MP 33 Compressor Station has been adjusted to minimize effects; however, due to the need to have a temporary laydown area adjacent to the site, placement of 1 ATWS within 50 feet of a PEM wetland is necessary. Erosion control BMPs will be installed for wetland protection.</li> <li>• The permanent footprint of the MP 63 interconnect has been co-located with existing infrastructure; however, due to the need to have a temporary laydown area adjacent to the site, placement of 1 ATWS over wetland areas is necessary. The ATWS was sited to take</li> </ul>

Table 2.5-3 Requested Alternative Measures from the 2013 FERC Procedures for GPX Pipeline Aboveground Facility Construction and Operation					
Variance No.	MP <sup>1</sup>	Applicable FERC Procedures Section	FERC 2013 Procedures Sub-Section	Golden Pass' Requested Alternative Measures ( <u>Alternative Measure Language Underlined</u> )	Justification
					<p>advantage of an existing access road. A new access road would result in additional wetland effects. Erosion control BMPs will be installed for wetland protection.</p> <ul style="list-style-type: none"> <li>The permanent footprint of the MP 66 Compressor Station has been adjusted to minimize effects; however, due to the need to have a temporary laydown area adjacent to the site, placement of 1 ATWS within 50 feet of a PEM wetland is necessary. Erosion control BMPs will be installed for wetland protection.</li> </ul> <p>Golden Pass will perform work related to the requested alternative measure in a conscientious manner and in accordance with applicable Federal and State environmental laws.</p>
21	1 66	VI. Wetland Crossings	<p><i>B. Installation 1. Extra Work Areas and Access Roads</i></p> <p><i>d. The only access roads, other than the construction right-of-way, that can be used in wetlands are those existing roads that can be used with no modifications or improvements, other than routine repair, and no impact on the wetland</i></p>	<p>Golden Pass is requesting an alternative measure for siting of access roads associated with construction and operation of the MP 1, MP 33 and MP 66 Compressor Stations in wetland areas:</p> <p><u>B. Installation 1. Extra Work Areas and Access Roads</u></p> <p><u>d. Access roads used in wetlands, other than the construction right-of-way, are to be limited to the extent practicable for safe construction and operation (if</u></p>	<p>Efforts were made to avoid or minimize effects to wetlands at all compressor station locations; however, due to the need to co-locate with existing natural gas infrastructure:</p> <ul style="list-style-type: none"> <li>At MP 1 Compressor Station, an existing access road to the abandoned well pad will be improved and modified for construction and permanent access. At the MP 66 Compressor Station an existing road will be used for construction and permanent access; however, extension of the</li> </ul>

Table 2.5-3 Requested Alternative Measures from the 2013 FERC Procedures for GPX Pipeline Aboveground Facility Construction and Operation					
Variance No.	MP <sup>1</sup>	Applicable FERC Procedures Section	FERC 2013 Procedures Sub-Section	Golden Pass' Requested Alternative Measures (Alternative Measure Language Underlined)	Justification
				<u>permanent) of the GPX Project facilities</u>	road will require minor filling of wetlands. Golden Pass will perform work related to the requested alternative measure in a conscientious manner and in accordance with applicable Federal and State environmental laws.
22	1	VI. Wetland Crossings	<i>B. Installation 4. Trench Dewatering Dewater the trench (either on or off the construction right-of-way) in a manner that does not cause erosion and does not result in silt-laden water flowing into any wetland. Remove the dewatering structures as soon as practicable after the completion of dewatering activities</i>	Golden Pass is requesting an alternative measure for trench dewatering discharge into the adjacent wetland area at the MP 1 Compressor Station and associated suction header: <u>B. Installation 4. Trench Dewatering In compliance with the Clean Water Act and applicable regulations, dewatering to wetland areas will be evaluated by the Environmental Inspector to ensure that contractors have taken appropriate steps that do not cause erosion and result in silt-laden water flowing. Removal of dewatering structures is to occur as soon as practicable after the completion of dewatering activities</u>	Related dewatering at the MP 1 Compressor Station and associated suction header construction area will require discharge into vegetated wetlands as adequate uplands for discharging do not exist on the GPLNG Terminal property. Golden Pass will implement other BMPs (i.e., dewatering structure, baffles) to ensure that the discharge does not cause erosion or otherwise impair water quality in the wetland complex. Golden Pass will perform work related to the requested alternative measure in a conscientious manner and in accordance with applicable Federal and State environmental laws.
23	1 33 66	VI. Wetland Crossings	<i>C. Restoration 2. Restore pre-construction wetland contours to maintain the original wetland hydrology</i>	Golden Pass is requesting an alternative measure from returning wetlands within the permanent footprint of the compressor stations to pre-construction contours: <u>C. Restoration 2.</u>	The wetlands within both the permanent facilities and construction laydown areas of the MP 1 Compressor Station are requested to be permanently filled. As the construction laydown area will need to be utilized for 5 years and require a substantial amount of fill to



Table 2.5-3 Requested Alternative Measures from the 2013 FERC Procedures for GPX Pipeline Aboveground Facility Construction and Operation					
Variance No.	MP <sup>1</sup>	Applicable FERC Procedures Section	FERC 2013 Procedures Sub-Section	Golden Pass' Requested Alternative Measures ( <u>Alternative Measure Language Underlined</u> )	Justification
				<u>Altered contours in previous, but subsequently filled, wetland areas will be permitted to remain following construction.</u> <u>Pre-construction contours will not be returned in permanently stabilized areas</u>	build a safe working area, restoration after construction will not be feasible. All wetlands within the permanent and construction workspace will be mitigated assuming permanent loss in coordination with the USACE and other applicable resource agencies and in accordance with the applicable provisions of the Clean Water Act. Golden Pass will perform work related to the requested alternative measure in a conscientious manner and in accordance with applicable Federal and State environmental laws.
24	1 33 63 66	VI. Wetland Crossings	<i>C. Restoration 6. Until a project-specific wetland restoration plan is developed and/or implemented, temporarily revegetate the construction right-of-way with annual ryegrass at a rate of 40 pounds/acre (unless standing water is present)</i>	Golden Pass is requesting an alternative measure from seeding the pre-construction wetland areas at the compressor station and interconnect sites: <u>C. Restoration 6. A project-specific wetland mitigation plan is to be developed and/or implemented prior to GPX Project operations</u>	Wetlands within the permanent footprint of the compressor station facilities will be mitigated assuming permanent loss in coordination with the USACE and other applicable resource agencies Golden Pass will perform work related to the requested alternative measure in a conscientious manner and in accordance with applicable Federal and State environmental laws.
25	1 33 63 66	VI. Wetland Crossings	<i>D. Post-Construction Maintenance and Reporting 2. Do not use herbicides or pesticides in or within 100 feet of a wetland, except as allowed by the appropriate federal or state agency</i>	Golden Pass is requesting an alternative measure to allow for the controlled use of herbicide or pesticides at the compressor station and interconnect sites adjacent to wetlands: <u>D. Post-construction Maintenance and Reporting 2. The use herbicides or pesticides on filled</u>	Golden Pass will perform work related to the requested alternative measure in a conscientious manner and in accordance with applicable Federal and State environmental laws. <sup>2</sup> Applies to the compressor station and interconnect sites adjacent to wetlands.



Table 2.5-3 Requested Alternative Measures from the 2013 FERC Procedures for GPX Pipeline Aboveground Facility Construction and Operation					
Variance No.	MP <sup>1</sup>	Applicable FERC Procedures Section	FERC 2013 Procedures Sub-Section	Golden Pass' Requested Alternative Measures (Alternative Measure Language Underlined)	Justification
				<u>areas in or within 100 feet of a wetland will be in accordance with industry best management practices and in a conscientious manner and in accordance with applicable Federal and State environmental laws.</u>	
<p><sup>1</sup> MP of the GP Pipeline.</p> <p><sup>2</sup> Per Variance No. 25 - Industry best management practices that would be employed when Golden Pass uses herbicides or pesticides at the compressor stations and interconnects adjacent to wetlands are as follows:</p> <p>General BMPs</p> <ul style="list-style-type: none"> <li>o Follow all label instruction. Be aware that some chemicals are labeled for use in wetland and some are not.</li> <li>o Use skilled and if required licensed applicants.</li> <li>• Planning             <ul style="list-style-type: none"> <li>o Know the chemical characteristics, topography, soils, drainage, and condition of bridges, weather and any other factors that might be important for preventing water pollution during application.</li> </ul> </li> <li>• Maintenance of Equipment             <ul style="list-style-type: none"> <li>o No visible leakage of chemicals should be permitted from equipment used for transporting, storing, mixing or applying chemicals.</li> </ul> </li> <li>• Mixing             <ul style="list-style-type: none"> <li>o Mix chemicals and clean tanks only where possible spills will not enter streams, lakes, or ponds. Do not mix chemicals or clean/flush tanks near well heads.</li> </ul> </li> <li>• Ground Application             <ul style="list-style-type: none"> <li>o Exercise care not to exceed intended or allowable dosage.</li> </ul> </li> <li>o Avoid applying chemicals to vegetation protecting eroded slopes, gullies, drainages and other fragile areas subject to erosion.</li> <li>• Managing Spills             <ul style="list-style-type: none"> <li>o Should a spill occur shovel up a dike around the spill. Use absorbent material (Kitty litter, slaked lime, saw dust, soil ect.) to soak up fluid. Keep spill from flowing into stream or bodies of water.</li> <li>o Some spills will require notifying appropriate authorities.</li> </ul> </li> <li>• Container Handling and Disposal             <ul style="list-style-type: none"> <li>o Before disposal, containers should be rinsed as described in equipment clean up. Containers shall be disposed of in accordance with manufactures recommendations.</li> </ul> </li> <li>• Equipment Clean Up             <ul style="list-style-type: none"> <li>o Clean up equipment in location where chemicals will not enter any stream, lake, pond, or where stream pollution might occur.</li> </ul> </li> </ul> <p>Note: Although above BMPs will be followed, GP intends to use non-wetland approved herbicide on the exterior of the property fence line in order be able to perform routine maintenance and prevent the proliferation of snakes/rats (prevent safety/security issues).</p>					

**APPENDIX I**  
**Dredged Material Management Plan**



## **Dredged Material Management Plan**

- **Access Float Channel**
- **Material Offloading Facility**
- **Temporary Float Channel**

**Golden Pass Products LNG Export Project**

**Jefferson County, Texas**

**Draft**

November 2015



## EXECUTIVE SUMMARY

An initial dredged material management plan was submitted by Golden Pass Products LLC (GPP) and Golden Pass Pipeline LLC (GPPL, collectively with GPP, referred to as Golden Pass), on July 7, 2014 as part of a Section 404 / Section 10 Department of the Army Permit Application under U.S. Army Corps of Engineers – Galveston District (USACE) File SWG-2004-02118 for the Golden Pass Products LNG Export Project (GPX Project). Modifications to the proposed volume and management of dredged material have been made as a result of USACE consultation and continued progress in the engineering design of the GPX Project. This document serves as an updated version of the GPX Project's Material Offloading Facility (MOF) and Temporary Float Channel Dredged Material Management Plan (DMMP).

This DMMP was developed to provide details pertaining to the dredging and disposal of excavated material related to construction of the:

- Access channel with connections to the MOF and the Sabine-Neches Waterway (SNWW);
- MOF and associated dredged prism; and,
- Temporary float channels required for revetment installation along the shoreline of the Golden Pass LNG facility.

The dredging area, estimated volume of dredged material, and the physical properties of the material are discussed in detail, for both the initial dredging and future maintenance dredging events. In addition, potential disposal areas are identified, discussed, and recommended.

The new work dredged material associated with construction of the access channel, MOF, and shoreline protection-related float channels primarily consists of clays, with some intermixed layers of sandy clays and silts; anticipated dredged material volumes are summarized in the table below. The composition of the maintenance dredging material is expected to be similar to that found in the existing ship slip, which primarily consist of fine sands, with some clays and silts.

<b>Dredged Material Volumes for MOF and Temporary Float Channels</b>		
<b>Feature</b>	<b>Estimated Dredged Material Volume (cubic yards)</b>	
	<b>New Work</b>	<b>Annual Maintenance</b>
Access Channel	63,000	20,000
MOF and Approach	305,750	25,000
Temporary float channels	86,700	N/A
<b>Totals</b>	<b>455,450</b>	<b>45,000</b>

Potential disposal options for the initial dredging and maintenance dredging material include use of Dredged Material Placement Areas (DMPAs) along the SNWW, use of offshore Ocean Dredged Material Disposal Sites (ODMDSs) or beneficial use (BU) in the nearby J.D. Murphree Wildlife Management Area (WMA). Disposal options were evaluated for compatibility with dredged material, location, required dredging equipment and probable cost. The WMA option was not recommended for new work dredged material due to the poor suitability of the clays expected to be dredged from the MOF and the access channel. However, maintenance dredged material may be suitable for BU within the WMA. Use of ODMDSs was not recommended for further development due to required use of specialized marine equipment, substantially longer dredging time, and relatively higher costs.



The option of disposing dredged material in DMPA No. 8, and potentially DMPA No. 9 along the SNWW was recommended for further development. Use of these DMPAs is dependent upon approval from the manager and/or facility owners. This approval could include, but may not be limited to, available volume within the disposal area, as well as results of dredged material testing for contaminated sediments.



**DREDGED MATERIAL MANAGEMENT PLAN  
 GOLDEN PASS PRODUCTS LNG EXPORT PROJECT**

**CONTENTS**

1.0 PROJECT INTRODUCTION..... 1

2.0 PROJECT INFORMATION ..... 1

    2.1 Access Channel ..... 1

    2.2 Marine Offloading Facility ..... 4

    2.3 Temporary Float Channels (Shoreline Protection Installation) ..... 4

    2.4 Initial Dredging ..... 7

        2.4.1 Existing Dredge Area..... 7

        2.4.2 Dredged Material Characterization ..... 9

        2.4.3 Dredged Material Volumes ..... 11

    2.5 Maintenance Dredging ..... 12

        2.5.1 Dredging Area ..... 12

        2.5.2 Dredged Material Characterization ..... 13

        2.5.3 Dredged Material Volumes ..... 13

3.0 DISPOSAL/REUSE OPTIONS..... 14

    3.1 Dredged Material Placement Areas (DMPAs) ..... 14

        3.1.1 PA-8 ..... 16

        3.1.2 PA-9 ..... 16

    3.2 Unconfined Disposal Areas ..... 17

        3.2.1 J.D. Murphree Wildlife Management Area (WMA) ..... 17

        3.2.2 Ocean Dredged Material Disposal Sites (ODMDSs) ..... 17

4.0 RECOMMENDED DISPOSAL/REUSE OPTIONS ..... 18



## **LIST OF TABLES**

Table 2.1	Relationship of Vertical Datum at GPX Project Site
Table 2.2	Composite Estimated Soil Classifications for the MOF and MOF Access Channel Dredging Areas
Table 2.3	Initial Dredged Material Volumes for MOF and Temporary Float Channels
Table 4.1	Disposal/Reuse Options Summary

## **LIST OF FIGURES**

Figure 1-1	GPX Project Dredge Areas - Overview
Figure 2-1	Access Channel Dredge Areas
Figure 2-2	MOF Dredge Areas
Figure 2-3	Temporary Float Channels Dredge Areas
Figure 2-4	Existing Conditions of Proposed MOF Location
Figure 2-5	Containment Berm
Figure 3-1	GPX Project Dredge Placement Locations

## **LIST OF APPENDICES**

Appendix A	July 2015 Bathymetry Survey Basin Condition Report
------------	--



## LIST OF ACRONYMS AND ABBREVIATIONS

BU	Beneficial use
CRA	Chris Ransome and Associates, Inc
cy	Cubic yards
DMMP	Material Offloading Facility and Temporary Float Channel Dredged Material Management Plan
GIWW	Gulf Intracoastal Waterway
Golden Pass	Collectively, GPP and GPPL
GPLNG	Golden Pass LNG Terminal LLC
GPLNG Terminal	Existing GPLNG LNG import terminal
GPP	Golden Pass Products LLC
GPPL	Golden Pass Pipeline LLC
GPX Project	Golden Pass Products LNG Export Project
GPX Terminal	Golden Pass Products LNG GPX Terminal Project
LDEQ	Louisiana Department of Environmental Quality
LDNR	Louisiana Department of Natural Resources
MLLW	Mean Lower Low Water
MOF	Material Offloading Facility
nm	nautical miles
ODMDS	Ocean Dredged Material Disposal Sites
SNND	Sabine Neches Navigation District
SNWW	Sabine-Neches Waterway
TPWD	Texas Parks and Wildlife Department
USACE	U.S. Army Corps of Engineers
WMA	J.D. Murphree Wildlife Management Area





---

# MATERIAL OFFLOADING FACILITY and TEMPORARY FLOAT CHANNEL DREDGED MATERIAL MANAGEMENT PLAN GOLDEN PASS PRODUCTS LNG EXPORT PROJECT

## 1.0 PROJECT INTRODUCTION

Golden Pass Products LLC (GPP) and Golden Pass Pipeline LLC (GPPL, collectively with GPP, referred to as Golden Pass) are proposing installation of LNG export facilities to the existing LNG import terminal (GPLNG Terminal) along the Port Arthur Ship Canal reach of the Sabine-Neches Waterway (SNWW) upstream of Sabine Pass in Port Arthur, Texas. This expansion, known as the Golden Pass Products LNG Export Project (GPX Project) would allow Golden Pass the flexibility to import or export natural gas in response to market conditions. The GPX Project includes construction of a new liquefaction facility (GPX Terminal) (**Figure 1-1**).

The objectives of this Dredged Material Management Plan (DMMP) are to:

- Summarize construction of the MOF, access float channel and temporary float channels;
- Provide an estimate of the sediment to be dredged (including initial dredging and maintenance dredging);
- Provide a review of possible dredged material disposal locations; and,
- Identify the preferred alternative(s) dredging method and area for dredged material disposal.

Note that this DMMP does not address removal of maintenance dredged material from the ship slip as dredging is authorized by an existing Department of the Army Permit. Details regarding maintenance dredging of the ship slip are found in the Draft Compensatory Mitigation Plan submitted to the U.S. Army Corps of Engineers – Galveston District on March 26, 2015.

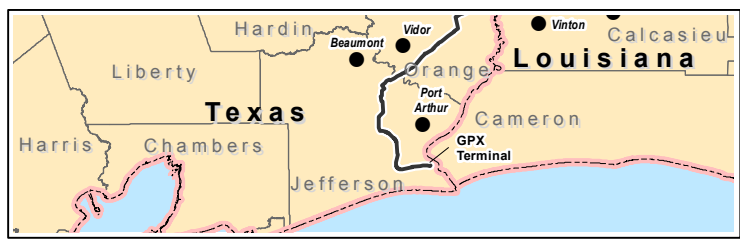
## 2.0 PROJECT INFORMATION

### 2.1 Access Channel

The GPX Project will dredge an access channel immediately west of the MOF so that granular material can be transferred from river barges to the construction site prior to installation of the MOF (**Figure 2-1**). This access channel will have an approximate maximum width of 200 feet, and a maximum depth of approximately -14 feet (NAVD88) and will allow barge access from the east, west and north (channel side). The dredged material would be transferred to an approved DMPA for disposal.

A barge with transfer equipment (e.g., extended reach backhoe) will be moored alongside the access channel such that it would allow for efficient offloading from river barges to shore. The construction contractor would abandon the access channel when it is no longer needed to support construction activities. It is envisioned that the access channel would be allowed to return to a stable elevation through normal alongshore sediment transport and infilling.

FIGURE 1-1 : GPX PROJECT DREDGE AREAS - OVERVIEW



**LEGEND**

- Ship Slip Dredge Maintenance Area (Note 2009 Permit)
- Dredge Areas
- Proposed GPX Expansion
- Existing GP Terminal Facility
- Existing Shoreline
- LiDAR Bathymetry

0 1,000 FEET

Figure 1-1 : GPX Project Dredge Areas - Overview

COUNTY:	ORANGE	DRAWN BY:	JK
STATE:	TEXAS	CHECKED BY:	JW
REV. NO.:	1	REVISION	ISSUED FOR REVIEW
	2	REVISION	ISSUED FOR REVIEW
	3	REVISION	ISSUED FOR REVIEW
DATE:	2015-09-25	PROJECTION:	NAD83 15N FT

**GOLDEN PASS PRODUCTS LNG EXPORT PROJECT**

SWG-2004-02118

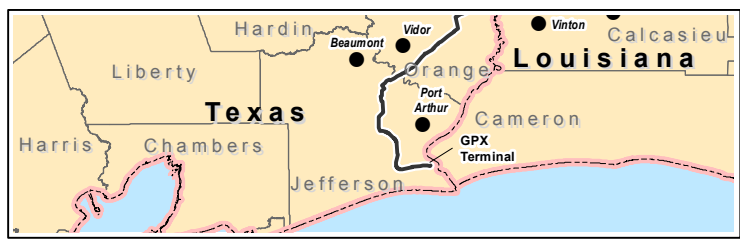
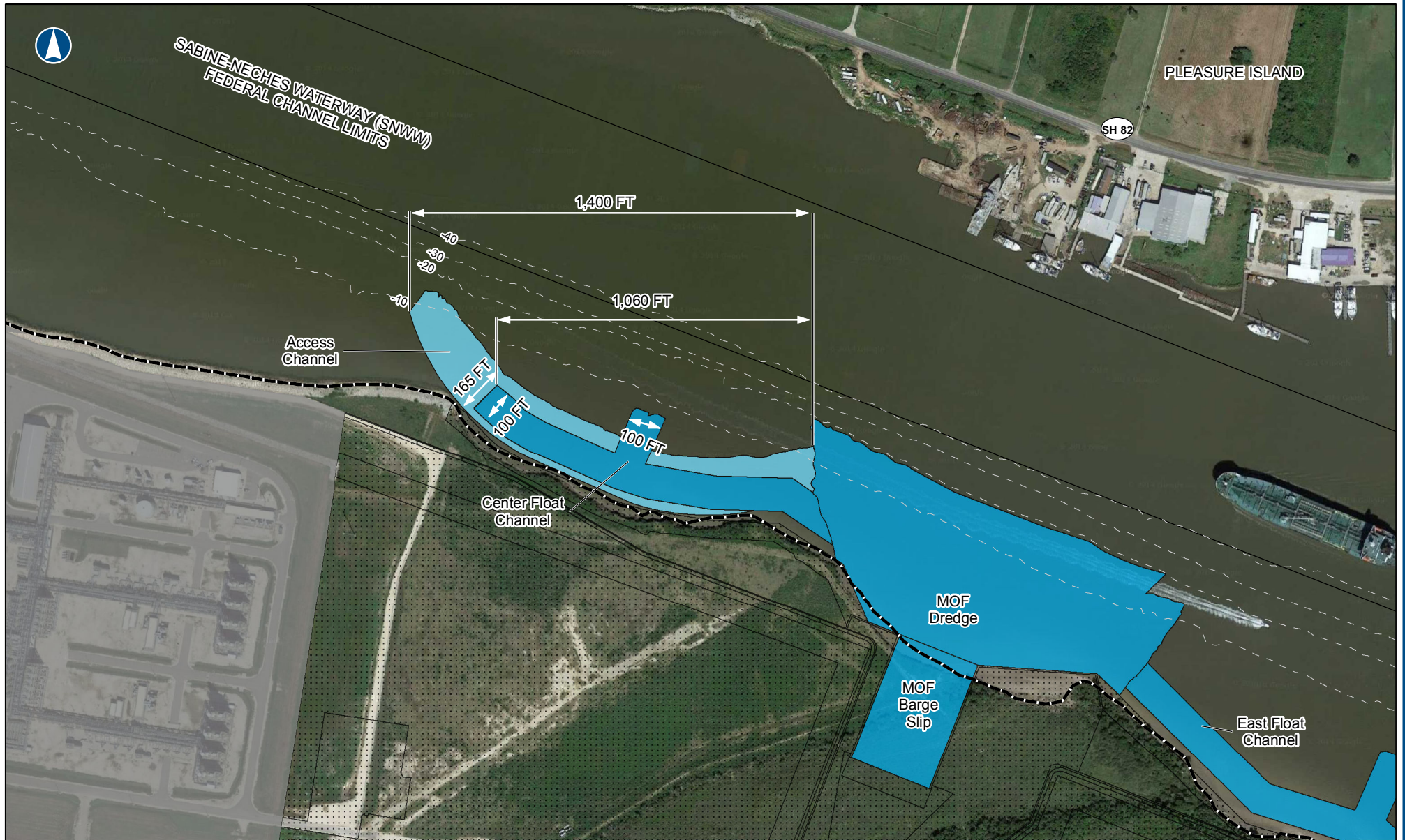
**Golden Pass Products**

**Golden Pass Pipeline**

DWG: GPX-1707-03-117 SHEET: 1



FIGURE 2-1 : ACCESS CHANNEL DREDGE AREAS



**LEGEND**

- Access Channel Dredge Area
- Other Dredge Areas
- Proposed GPX Expansion
- Existing GP Terminal Facility
- Existing Shoreline
- LiDAR Bathymetry

0 FEET 400

*Figure 2-1 : Access Channel Dredge Areas*

COUNTY: ORANGE		DRAWN BY: JK
STATE: TEXAS		CHECKED BY: JW
REV. NO.:	REVISION	DATE
1	ISSUED FOR REVIEW	2015-08-05
2	ISSUED FOR REVIEW	2015-08-10
3	ISSUED FOR REVIEW	2015-09-25
DATE:	2015-09-25	PROJECTION: NAD83 15N FT

**GOLDEN PASS PRODUCTS LNG EXPORT PROJECT**  
SWG-2004-02118

DWG: GPX-1707-03-117	SHEET: 1
----------------------	----------



## 2.2 Marine Offloading Facility

The Material Offloading Facility (MOF) will be installed to support construction of the new liquefaction facilities. Initially, the purpose of the MOF is to serve as a platform to offload shipments of granular fill material, and during later stages of construction serve to transfer bulk material and equipment. It is anticipated that the MOF will be used throughout the expected five (5) year construction period. During operations, the MOF may be used for facility turnaround or other maintenance events.

Construction of the MOF (**Figure 2-2**) includes a:

- Dredged fairway or entrance in submerged lands extending from the federal navigation channel (i.e., SNWW) to the existing shoreline; and,
- Excavation and/or dredging of existing uplands artificially created by storage of former dredged material and surrounding coastal emergent marsh.

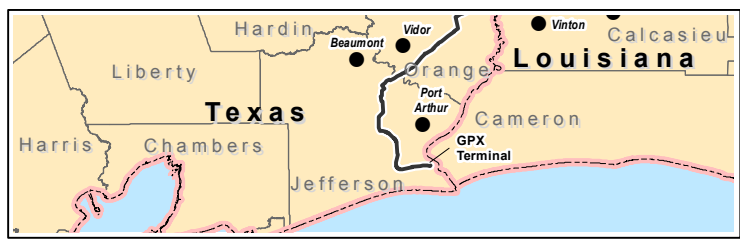
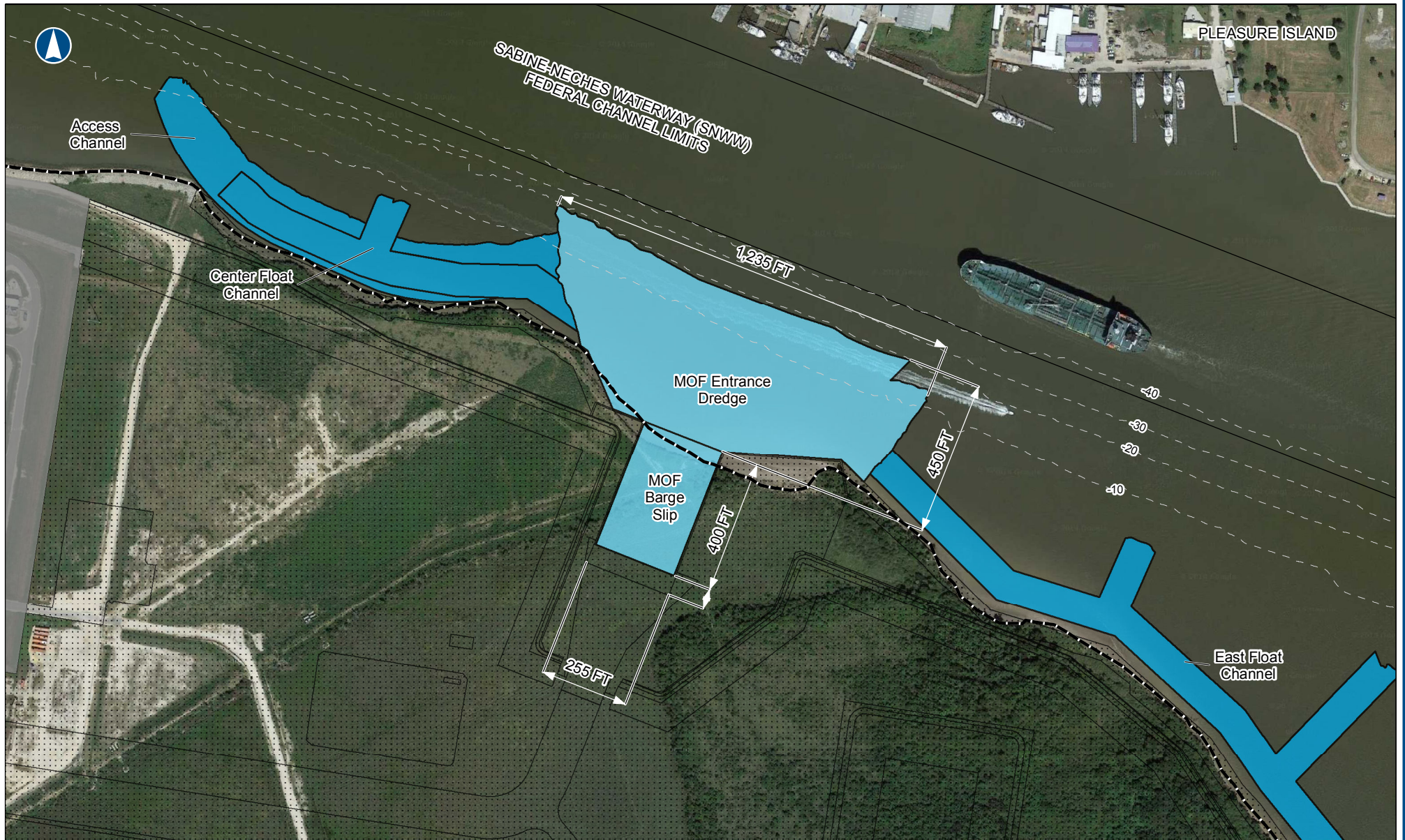
The MOF dimensions are approximately 400 feet long by 240 feet wide. The MOF will be dredged to a depth of -19.6 feet NAVD88 (-20 feet Mean Lower Low Water [MLLW]) with an additional 2-foot over-dredge allowance. The associated dredged prism will connect the federal navigation channel (SNWW) with the MOF and serve as a turning and maneuvering basin for Project related ocean-going and river barges.

## 2.3 Temporary Float Channels (Shoreline Protection Installation)

The GPX Project also involves construction of approximately 5,500 feet of new rock revetment along the shoreline of the SNWW to stabilize the actively eroding shoreline (**Figure 2-3**). The revetment could be constructed from: (a) upland areas using land equipment; (b) the water using marine equipment; or (c) a combination of the two methods. Since quality stone material from upland sources is not locally available, some contractors may determine that it is cost effect to transport stone materials using river barges. If a marine construction approach is undertaken, temporary float channel dredging would be dredged to allow access for marine equipment to the shoreline. It is currently anticipated that no float channel dredging would occur if the revetment is constructed using land based equipment.



FIGURE 2-2 : MOF DREDGE AREAS



- LEGEND**
- MOF Dredge Area
  - Other Dredge Areas
  - Proposed GPX Expansion
  - Existing GP Terminal Facility
  - Existing Shoreline
  - LIDAR Bathymetry

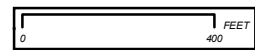


Figure 2-2 : MOF Dredge Areas

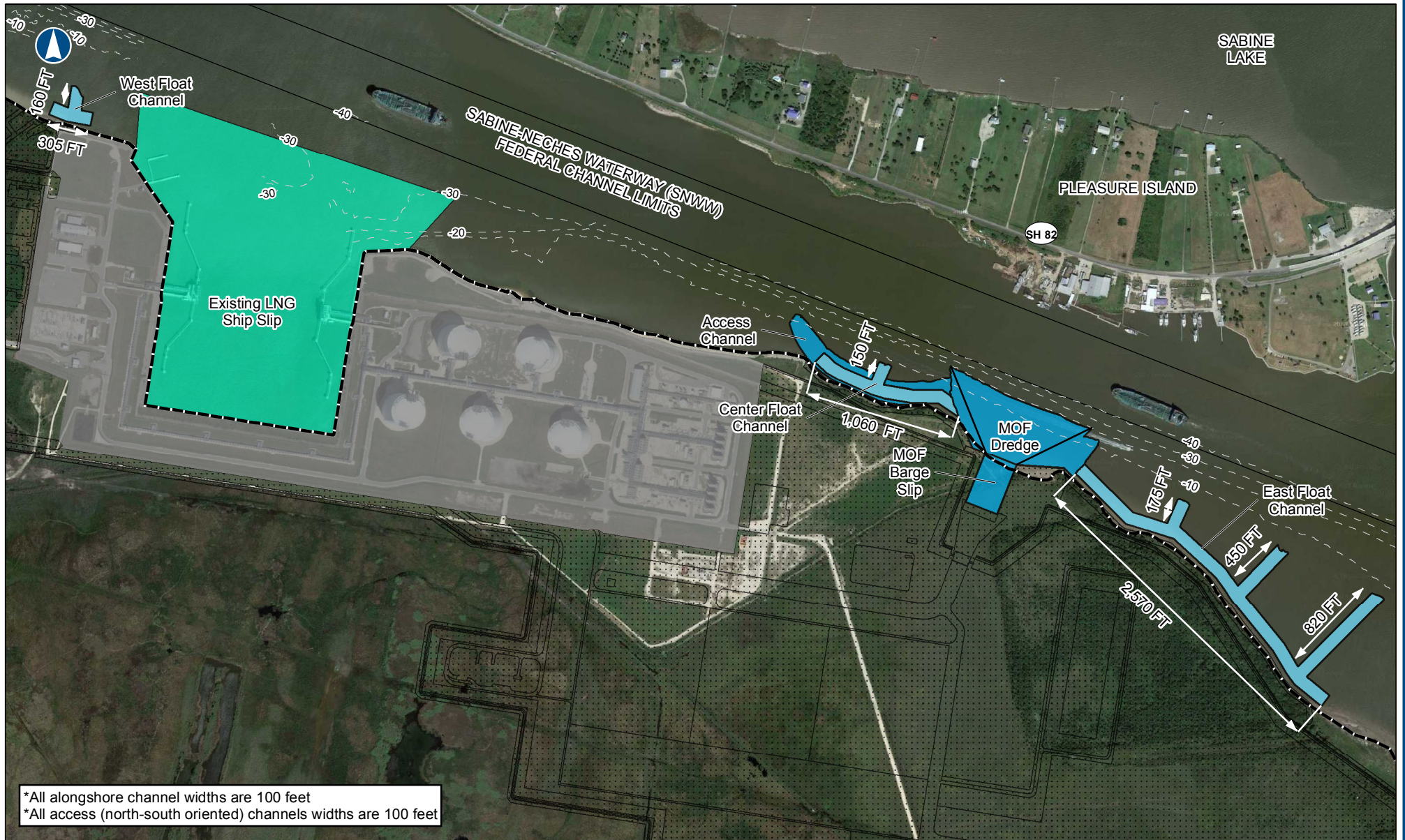
COUNTY:	ORANGE	DRAWN BY:	JK
STATE:	TEXAS	CHECKED BY:	JW
REV. NO.:	1	REVISION	ISSUED FOR REVIEW
	2	REVISION	ISSUED FOR REVIEW
	3	REVISION	ISSUED FOR REVIEW
DATE:	2015-09-25	PROJECTION:	NAD83   15N FT

**GOLDEN PASS PRODUCTS LNG EXPORT PROJECT**

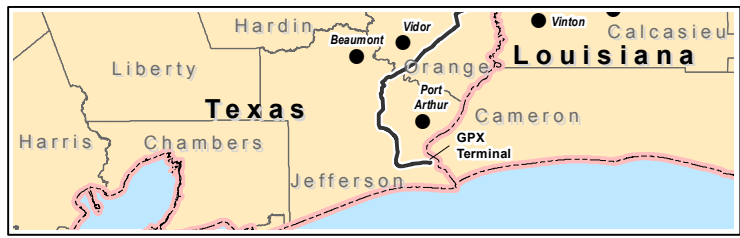
DWG: GPX-1707-03-117 SHEET: 1



FIGURE 2-3 : TEMPORARY FLOAT CHANNEL DREDGE AREAS



\*All alongshore channel widths are 100 feet  
 \*All access (north-south oriented) channels widths are 100 feet



**LEGEND**

- Ship Slip Dredge Maintenance Area (Note 2009 Permit)
- Temporary Float Channel Dredge Areas
- Other Dredge Areas
- Proposed GPX Expansion
- Existing GP Terminal Facility
- Existing Shoreline
- LiDAR Bathymetry

0 FEET 1,000

Figure 2-3 : Temporary Float Channel Dredge Areas

COUNTY: ORANGE		DRAWN BY: JK
STATE: TEXAS		CHECKED BY: JW
REV. NO.	REVISION	DATE
1	ISSUED FOR REVIEW	2015-05-05
2	ISSUED FOR REVIEW	2015-08-17
3	ISSUED FOR REVIEW	2015-09-25
DATE: 2015-09-25		PROJECTION: NAD83 15N FT

**GOLDEN PASS PRODUCTS LNG EXPORT PROJECT**

SWG-2004-02118

DWG: GPX-1707-03-117 SHEET: 1



## 2.4 Initial Dredging

### 2.4.1 Existing Dredge Area

Dredging of the MOF and access channel will be conducted to -19.6 feet NAVD88 or -20 feet MLLW, with an additional 2-foot over-dredge allowance. **Table 2.1** provides a tabular comparison of the various vertical datum used on the lower portion of the SNWW at the GPLNG Terminal. All elevations in this DMMP are provided in NAVD88 unless otherwise noted.

Datum			As compared to NAVD88
Mean Higher High Water (MHHW)	0.00 feet MHHW	=	1.02 feet NAVD88
Mean High Water (MHW)	0.00 feet MHW	=	0.93 feet NAVD88
Mean Sea Level (MSL)	0.00 feet MSL	=	0.43 feet NAVD88
Mean Tide Level (MTL)	0.00 feet MTL	=	0.42 feet NAVD88
Mean Low Water (MLW)	0.00 feet MLW	=	-0.10 feet NAVD88
Mean Lower Low Water (MLLW)	0.00 feet MLLW	=	-0.45 feet NAVD88
North American Vertical Datum 1988 (NAVD88)	0.00 feet NAVD88	=	0.00 feet NAVD88
National Geodetic Vertical Grid of 1929 (NGVD29)	0.00 feet NGVD29	=	0.03 feet NAVD88
Corps of Engineer's Mean Low Tide (MLT)	0.00 feet MLT	=	-1.60 feet NAVD88
Golden Pass LNG Plant Datum	0.00 feet Plant	=	-92.68 feet NAVD88

The GPX Project sponsored topographic and hydrographic surveys on April 16-18, 2014 and August 2-4, 2014 to support design of coastal features. The SNNW shoreline near the proposed MOF area (**Figure 2-4**) consists of a steep banked, wave-cut shoreline, with an eroding bank height of approximately 8 to 10 feet. The elevation of the upland and coastal marsh areas within the proposed MOF excavation dredge limits range from approximately +2 feet NAVD88 at the southwest corner to +11 feet NAVD88 near the shoreline. Additionally, the containment berm (**Figure 2-5**) used during previous dredged material placement has a top elevation of approximately +15 feet NAVD88 and crosses through the western side of the proposed MOF excavation.





**Figure 2-4 Existing Conditions of the Proposed MOF Location**

Along the SNWW shoreline, the base of the wave-cut bank is a low angled bench of washed sediments eroded from the bank that range in elevation from +3 feet NAVD88 at the toe of the bank to federal navigation channel limits.

In the event that a marine construction approach is undertaken during construction of the shoreline protection, temporary float channels of up to 100 feet wide may be constructed. Dredging of the float channel would be conducted up to -7.0 feet NAVD88. The elevation of the existing bathymetry within the proposed float channel excavation limits ranges from approximately +0 feet NAVD88 nearest the shoreline and ties into the -7 feet NAVD88 contour at the seaward limits. Marine equipment used to construct the revetment would likely include a construction crane barge, excavators and material barges. The float channel dredging would be conducted by a large excavator, a hydraulic dredge, or a dragline to mechanically dredge these access channels. All float channel dredging would be considered temporary and the channels would be for use only during construction of the shoreline protection work. Once the shoreline protection features are installed, the float channels would be abandoned in place, allowing for natural sediment transport processes to fill the channels.



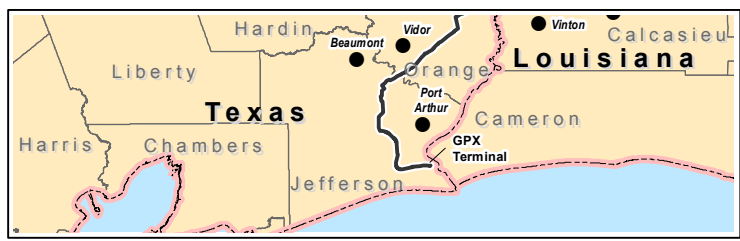
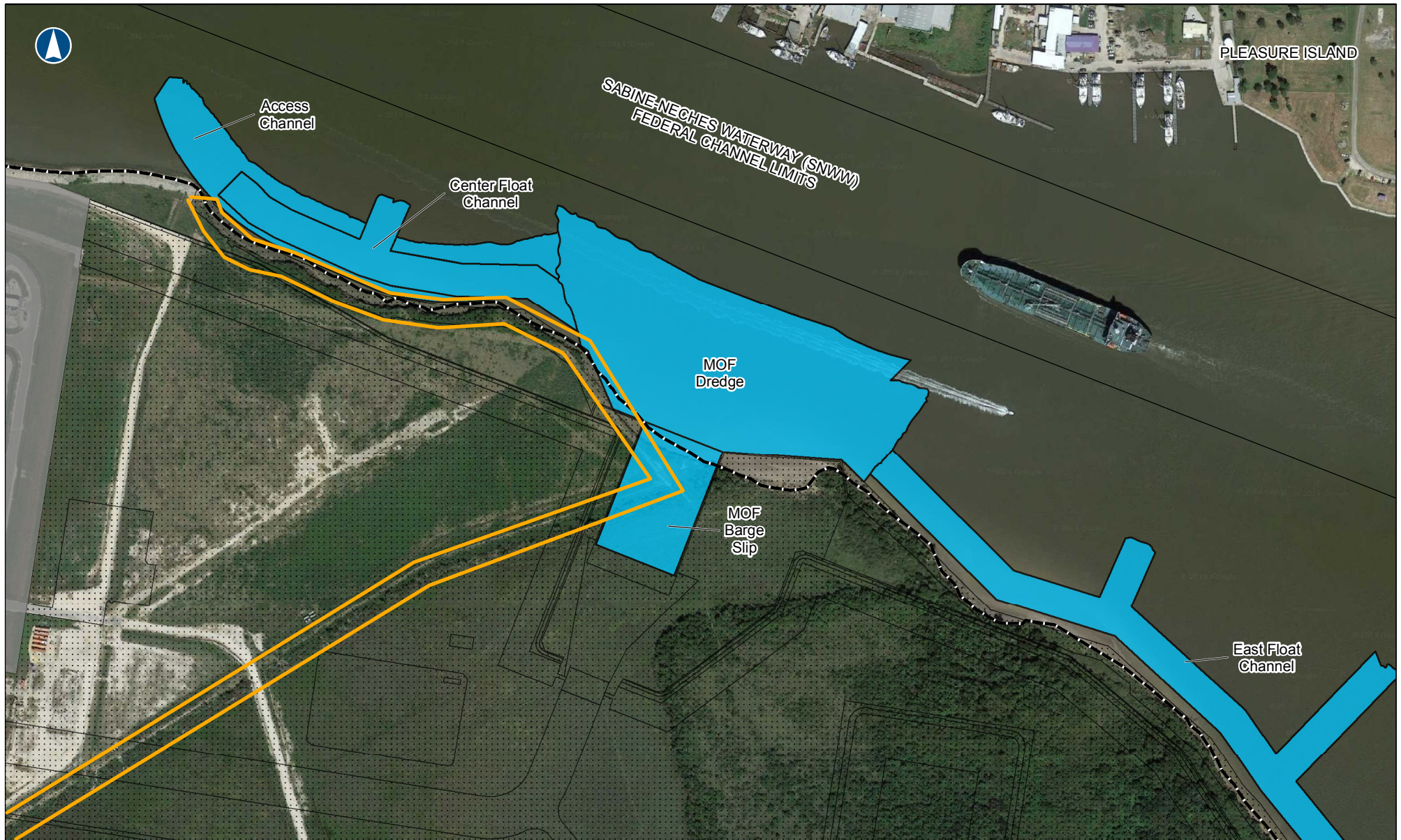


## 2.4.2 Dredged Material Characterization

Knowledge of the subsurface soil (sediment) physical and chemical properties is critical to successful dredging and dredged material disposal design. A 2013 geotechnical investigation characterized the subsurface materials of the proposed liquefaction facility. A second geotechnical investigation conducted in 2014 characterized the subsurface materials in the area of the proposed MOF. The data collected from these investigations were utilized in the development of this DMMP.

Based on available physical properties and geotechnical information, the soils at the MOF and access float channel dredging locations are predominately comprised of clay, with an intermixed layer of sandy clays and silts (generally between elevations +8 foot NAVD88 and +1 foot NAVD88).

FIGURE 2-5 : CONTAINMENT BERM



**LEGEND**

- Former Dredge Placement Area Berm
- Dredge Areas
- Ship Slip Dredge Maintenance Area (Seperate Permit)
- Proposed GPX Expansion
- Existing GP Terminal Facility
- Existing Shoreline

0  400 FEET

Figure 2-5 : Containment Berm

COUNTY: ORANGE		DRAWN BY: JK
STATE: TEXAS		CHECKED BY: JW
REV. NO.:	REVISION	DATE
1	ISSUED FOR REVIEW	2015-05-05
2	ISSUED FOR REVIEW	2015-08-10
3	ISSUED FOR REVIEW	2015-09-25
DATE:	2015-09-25	PROJECTION: NAD83 15N FT

**GOLDEN PASS PRODUCTS LNG EXPORT PROJECT**

SWG-2004-02118

DWG: GPX-1707-03-117 SHEET: 1



**Table 2.2** provides a summary of the interpreted soil layers within the MOF and the access float channel dredging areas.

<b>Table 2.2 Composite Estimated Soil Classifications for the MOF and MOF Access Channel Dredging Areas</b>		
<b>Estimated Soil Classification</b>	<b>Elevation Range (feet-NAVD88)</b>	<b>Nominal Thickness (feet)</b>
Sand Fill ( <i>dredged fill</i> )	+15 to +11	4
Stiff Clay ( <i>dredged fill</i> )	+11 to +8	3
Sandy Clays and Silts ( <i>dredged fill</i> )	+8 to +1	7
Soft Clay	+1 to -17	18
Silty Sand	-17 to -21.6	4.6

Testing for chemical properties of the material to be dredged in the MOF construction has not yet been conducted. Previous project experience from the new work dredging of the GPLNG Terminal ship slip in 2007 indicates that sediments are suitable for disposal as non-contaminated sediments. However, testing will be completed as required by managers and owners of the disposal areas, and applicable regulatory agencies to confirm the suitability of the actual material to be dredged.

### 2.4.3 Dredged Material Volumes

The volume of dredging for the MOF, its associated features (dredge Prism, over-dredge), and the access float channel were estimated using the recent (July 2015) bathymetry/elevation survey dataset (**Appendix A**). The bottom of dredging for the MOF and access float channel is -19.6 feet NAVD88 or -20 feet MLLW with an additional 2-foot over-dredge allowance. The bottom of dredging including the over-dredge allowance is -21.6 feet (NAVD88) (-22 feet MLLW). Additionally, a 350-foot long bulkhead wall on the east side of the MOF will be dredged to a depth of -14 feet with an additional 2-foot over-dredge allowance. Side slopes for the volume analysis were estimated using industry standard rules for design of navigation channels (NAVFAC DM-38.2 and I.C.E – Dredging Design and Practice Guide).

The primary soil type within the MOF and access float channel dredging areas consist of clay of varying stiffness. It is important to note that the soil stiffness will directly influence the final side slope angles. Stiffer clays can have side slopes of up to 1V (vertical):1.5H (horizontal) or even steeper while side slopes cutting through softer clays could be as low as 1V:8H. For the purpose of this volume estimate, an intermediate slope of 1V:5H is assumed. As shown in **Table 2.3**, the volume of initial dredged material for the access channel and MOF with its associated features is estimated to be 368,750 cubic yards (cy).





<b>Table 2.3 Initial Dredged Material Volumes for MOF and Temporary Float Channels</b>		
<b>Feature</b>		<b>Initial Dredge Volume (cy)</b>
<b>Access Float Channel</b>		<b>63,000</b>
<b>MOF</b>	Dredge Prism	265,500
	Over-dredge	40,250
<b>MOF subtotal</b>		<b>368,750</b>
<b>Temporary Float Channels</b> (shoreline protection installation)	West Channel	8,500
	Center Channel	18,100
	East Channel	60,100
<b>Temporary Float Channel subtotal</b>		<b>86,700</b>
<b>Totals</b>		<b>455,450</b>

The dredge volume for the temporary float channels was estimated by comparing the proposed channel cut depth of -7.0 feet NAVD88 to the recent July 2015 bathymetry survey. All float channel dredging would be considered temporary and for use only during construction of the shoreline protection work. As shown in **Table 2.3**, the total estimated volume for the temporary float channels is 86,700 cy. This estimate is conservative and assumes that the extents of the channel, both horizontal and vertical limits, will be dredged. However, the contractor is not required to dredge the extents of the channel – only what is needed to gain safe access to complete the construction of the shoreline protection work.

## 2.5 Maintenance Dredging

### 2.5.1 Dredging Area

After installation of the access float channel and the MOF, periodic maintenance dredging is required to maintain navigation depths for barge and tug access throughout construction, which is expected to be about 5 years. The annual maintenance dredge volumes are estimated to be 25,000 cy for the prism and 20,000 cy for the access float channel. Based on experience from the nearby GPLNG Terminal ship slip, shoaling within the MOF basin and the access channel will likely occur. The source of this shoaling will likely be a combination of bedload and suspended sediment transport caused by river and tidal current flows as well as by waves and vessel generated currents. Additionally, some sloughing and flattening of the access channel dredge cut slope can be expected to contribute to shoaling within the MOF and the float channel.

Any temporary float channel dredging to allow access for marine equipment at the shoreline will only be conducted during construction of the shore protection, with no maintenance dredging expected.



## 2.5.2 Dredged Material Characterization

Sedimentation within the MOF, the access float channel, and the outer MOF basin will likely consist of a large percentage of fine sands transported along the edges of the waterway by either suspended or bedload transport or dredge slope sloughing. Sedimentation near the interior areas and corners of the MOF basin may be more quiescent and experience less hydraulic influence from the SNWW, making these areas more likely to accumulate finer grained sediments, such as silts and clays.

Testing for chemical properties of the material to be dredged in the access float channel, MOF and its approach will be conducted prior to maintenance dredging activities. Testing will be completed as required by managers and owners of the disposal areas and applicable regulatory agencies to confirm the suitability of the actual material to be dredged.

## 2.5.3 Dredged Material Volumes

An estimate of the expected maintenance dredging volume of the MOF and access float channel areas has been made based on an analysis of the survey data collected and sedimentation rates at the GPLNG Terminal ship slip. After initial dredging of the ship slip in 2007, Chris Ransome and Associates, Inc (CRA) conducted monthly multibeam hydrographic surveys from December 2007 until June 2010. Maintenance dredging of the area was conducted in 2011 and monitoring hydrographic surveys were conducted by Lanier and Associates every 6 months from June 2012 to July 2015. Although the existing GPLNG Terminal ship slip is substantially larger in area and dredged to a significantly deeper depth, analysis of these surveys to assess sedimentation rates provides guidance to develop an estimate of the expected sedimentation rate within the MOF basin and the access float channel after its construction. The GPLNG Terminal ship slip was dredged in 2007 to a design depth of -42 feet MLLW, including an additional 2 foot for over-dredge allowance. Based on the CRA data, between January 2008 and January 2009, 12 to 15 feet of sediment accumulated within the ship slip, reducing the controlling bottom elevations in the ship slip to between -25 to -28 feet. The following year, shoaling reduced controlling bottom elevations within the ship slip to -21 to -24 feet, translating to an annual accretion rate of 2.4 to 3.2 feet per year.

The Lanier and Associates survey data, which were collected after maintenance dredging was conducted in 2011, demonstrate a similar pattern, with significant shoaling occurring in the first year after dredging subsequently followed by decreased sedimentation rates. From July 2013 to January 2014, between 2.0 and 2.5 feet of sediment accumulated in the ship slip resulting in a controlling depth in January 2014 of -25 to -30 feet. This translates to an annual accretion rate of approximately 3.8 to 4.6 feet per year. The trend between the two datasets of post dredge monitoring data (CRA and Lanier Associates) indicates a very high accumulation of sediment in the 1 to 2 years following dredging. As shoaling reduces the bottom depths to -20 feet to -25 feet MLLW, the effective rate of sediment accumulation reduces to approximately 2.4 to 4.6 feet per year and is clearly a function of the active depth in the shoaling area. Consequently, a lower sedimentation rate is to be expected with the shallower the water depth.

The dredging elevation of the MOF (-19.6 NAVD88/-20 MLLW plus an additional 2 foot over-dredge) is less than the depths observed in the data at the conclusion of the survey monitoring periods for the GPLNG Terminal ship slip. Thus, the sedimentation rate is expected to be lower.



Additionally, installation of shore protection on both the east and west sides of the MOF may also reduce contributing sediment material by preventing erosion of some source material from the shoreline. Based on these observations and assumptions, the sedimentation rate within the MOF is estimated to be between 2 to 3 feet per year, while elevations are maintained between -19.6 and -21.6 feet MLLW. Applying this sedimentation rate uniformly across the MOF and the access float channel, approximately 45,000 cy of material to be removed annually. Over the 5 year construction schedule, the total maintenance dredge volume for the access channel and the MOF is approximately 225,000 cy.

### 3.0 DISPOSAL/REUSE OPTIONS

A number of options for dredged material disposal are available along the SNWW and offshore in the Gulf of Mexico. The options considered for this DMMP included:

- DMPAs currently used by the USACE and the Sabine Neches Navigation District (SNND);
- Potential marsh restoration in the WMA; and
- Offshore disposal in the Gulf of Mexico within designated ODMDs.

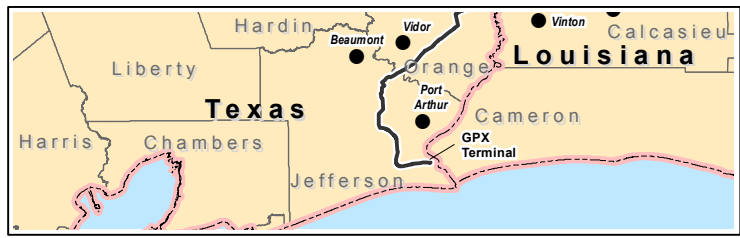
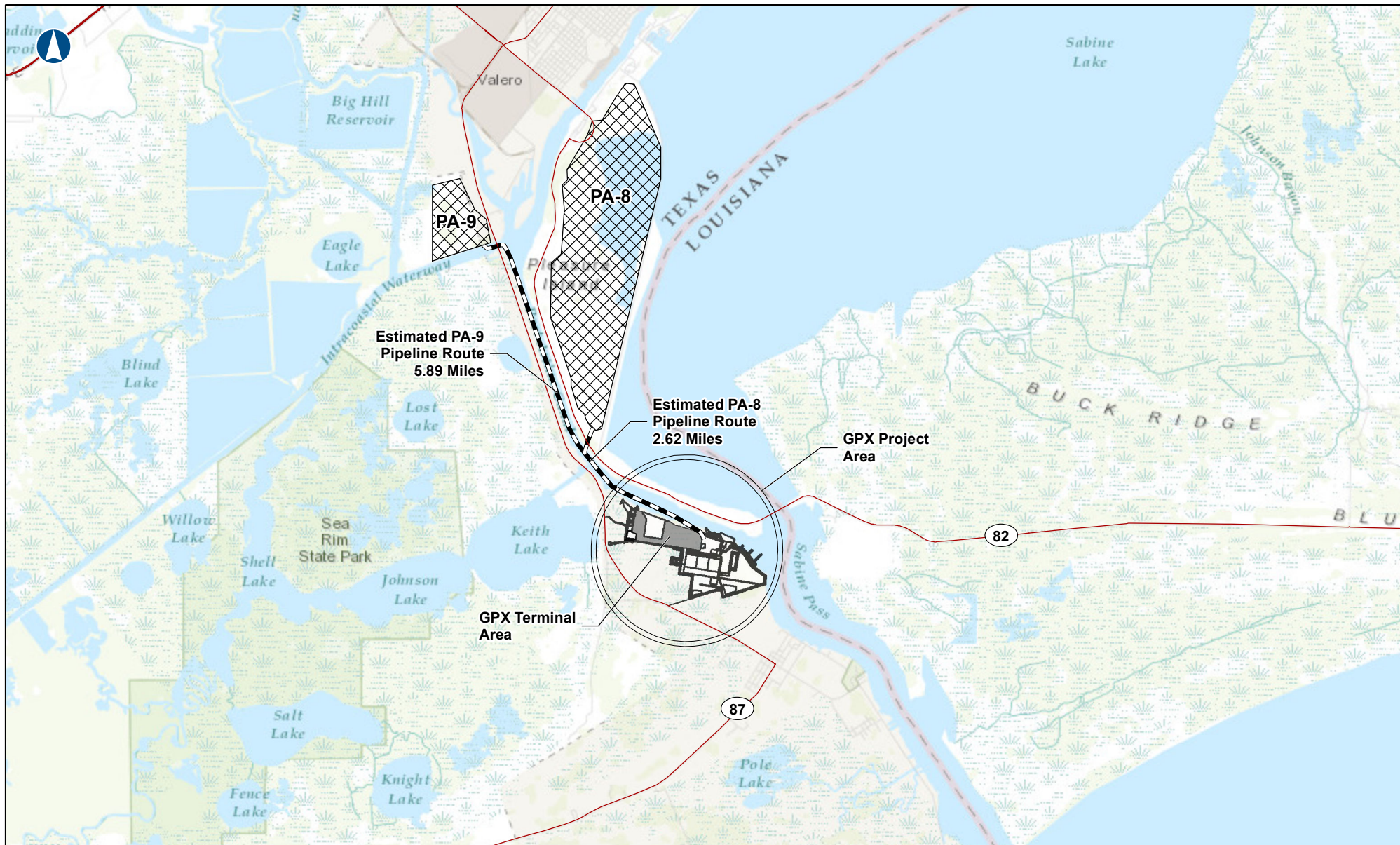
These disposal options are described in more detail below.

#### 3.1 Dredged Material Placement Areas (DMPAs)

DMPAs (PA-8 and PA-9) are located along the SNWW (**Figure 3-1**) and were considered for this DMMP based on their location. These DMPAs are upland confined facilities that contain levees on all sides with one or more weir structures that allows the decant water from hydraulic dredging operations to flow back into the SNWW as dredged sediments settle out within the placement area. Dredged material is pumped into the DMPA at different locations for allowing the material to spread as evenly as possible. Weir boards on the outlet structures are used to contain the decant water until the suspended solids are at, or below, concentrations found in the SNWW, whereupon the decant water is released back into the SNWW. The DMPAs along the SNWW could be considered for use for both the initial dredging work and subsequent maintenance dredging.



FIGURE 3-1 : GPX PROJECT DREDGE PLACEMENT LOCATIONS



**LEGEND**

- Dredge Placement Areas
- Existing GP Terminal Facility
- Proposed GPX Expansion
- Pipeline Routes

0 1 2 MILES

Figure 3-1 : GPX Project Dredge Placement Locations

COUNTY:	ORANGE	DRAWN BY:	JK
STATE:	TEXAS	CHECKED BY:	JW
REV. NO.:	REVISION	DATE	
1	ISSUED FOR REVIEW	2015-05-05	
2	ISSUED FOR REVIEW	2015-08-17	
3	ISSUED FOR REVIEW	2015-09-29	
DATE:	2015-09-29	PROJECTION:	NAD83 15N FT

**GOLDEN PASS PRODUCTS LNG EXPORT PROJECT**

SWG-2004-02118

DWG: GPX-1707-03-118 SHEET: 1



### 3.1.1 PA-8

PA-8 is a confined DMPA located approximately 2.5 nautical miles (nm) north of the GPX Project along the SNWW, on Pleasure Island. The PA-8 DMPA is currently managed by the USACE and consists of an area of approximately 3,570 acres (USACE, 2012). This DMPA is currently in use and available to receive dredged materials. For placement of the dredged material in PA-8, sediment at the GPX Project site would be hydraulically removed with a cutterhead suction dredge. Mechanical dredging with disposal at PA-8 is not currently an option since offloading facilities are not available at the disposal area. Utilizing a hydraulic dredge, fluidized sediment would be pumped through floating and submerged pipelines for discharge within PA-8. Sediment would fall out of suspension within the placement area and the dredge decant water would return through discharge weirs to the SNWW.

PA-8 is approximately four (4) miles long in the north-south direction. Depending on the dredge equipment selected for this work and the cells within the DMPA that are available for discharge, a dredge booster pump may be required to pump to the farthest reaches of the DMPA. This would be likely as the USACE typically requires private entities to place materials in the far reaches of the placement area. Since PA-8 is managed by the USACE, permissions for placement within this DMPA would need to be obtained. Approval for use is expected to be contingent upon the available volume within the disposal area. Also, approval is expected to be contingent upon results of dredge material testing for contaminated sediments, payment of placement fees for its use and regulatory authorizations.

### 3.1.2 PA-9

PA-9 is a confined DMPA located approximately five (5) to six (6) nm north of the GPX Project site along the Gulf Intracoastal Waterway (GIWW), near its confluence with the SNWW. The PA-9 DMPA is currently managed by the USACE and consists of an area of approximately 481 acres (USACE, 2012). For placement of the dredged material in PA-9, sediment at the GPX Project site would be hydraulically removed with a cutterhead dredge. Mechanical dredging with disposal at PA-9 is not an option since offloading facilities are not available at the disposal area. Utilizing a hydraulic dredge, fluidized sediment would be pumped through floating and submerged pipelines for discharge within PA-9. Sediment would fall out of suspension within the placement area and the dredge decant water would return through discharge weirs to the GIWW. Depending on the dredge equipment selected for this work and the cells within PA-9 that are available for discharge, a dredge booster pump would be required to pump to the DMPA. Since PA-9 is managed by the Sabine Neches Navigational District (SNND), permissions for placement within this DMPA would need to be obtained. Approval for use is expected to be contingent upon the available volume within the disposal area. Also, approval is expected to be contingent upon results of dredge material testing for contaminated sediments, payment of placement fees for its use and regulatory authorizations.





## 3.2 Unconfined Disposal Areas

### 3.2.1 J.D. Murphree Wildlife Management Area (WMA)

The WMA is managed by TPWD and located approximately two (2) nm west of the GPX Project site. Disposal to this site would be of beneficial use (BU) to restore eroded coastal marsh. Previous dredging operations at the GPLNG Facility placed materials at the WMA for BU. Unfortunately, the majority of the sediments expected from the initial dredging of the MOF, the access float channel and temporary float channels are expected to be clay. Based on communications with TPWD, clay materials are not suitable for disposal placement in the available WMA sites.

The maintenance material dredged from the GPLNG Terminal ship slip in 2011 were considered suitable for BU at the time of dredging and were disposed of at the WMA. It is reasonable to assume that similar sediment types will be dredged in the access float channel and MOF during maintenance dredging and thus the WMA may be suitable as an unconfined disposal area. However, this will be dependent on the characteristics of maintenance dredging material and will need to be determined prior to future maintenance dredging events.

### 3.2.2 Ocean Dredged Material Disposal Sites (ODMDSs)

There are four (4) unconfined ODMDSs disposal areas located in the Gulf of Mexico. These sites are ODMDS-1, ODMDS-2, ODMDS-3 and ODMDS-4 and all are located outside the Sabine Pass jetties. The distance from the GPX Project site to these areas ranges from 10 to 22 nm, with ODMDS 4 being the closest to the site and ODMDS 1 being the farthest. These placement areas are managed by the USACE.

The construction method for dredging and dredged material disposal at the ODMDSs would likely include mechanical dredging of sediments at the GPX Project site with loading onto hopper barges for transport by barge to the disposal area. Transported material would then either be unloaded from the barges using hydraulic unloaders or by bottom dumping. For disposal of the dredged material at the ODMDS sites offshore of Sabine Pass, dredged material would need to be transported to the offshore locations. This would likely be conducted using a series of hopper barges that would be transported to the ODMDS location by tugs. At the dredging location, sediment would be loaded onto the barges using mechanical dredging methods. Hydraulic dredging methods would not likely be used because the fluidized dredge materials would consist mostly of water with clays and silts and thus would not be practical. Additionally, the mechanized dredging method would result in a slower dredge production rate and have higher costs from extended marine activities and construction.

This dredging approach would be substantially slower than hydraulic dredging and require significantly more specialized marine equipment (hopper barges, tugs, hydraulic unloaders, etc.). Based on previous project experience, the construction cost of this method could be two to three times the cost of disposal within the nearby confined disposal facilities. Additionally, the ODMDS sites are managed by the USACE and are typically used for disposal of dredged material from maintenance dredging activities in the Sabine Pass entrance and outer channel. Disposing of material from inland projects such as the GPX Project would be unusual.



Testing of the dredged material for contaminated sediments would also need to be conducted and additional approvals and assessments may require close review of the potential impacts to nearby beaches from the placement of large quantities of fine grained, cohesive sediments in these offshore disposal areas.

#### 4.0 RECOMMENDED DISPOSAL/REUSE OPTIONS

Based on a review of the available options for disposal of the initial dredged material from the GPX Project, disposal to DMPAs No. 8, and/or DMPA 9 is recommended to be developed further. These DMPAs will continue to be considered as options for the dredging work, with selection of the actual DMPA used to be dependent on factors such as available volume of the disposal area at the time of dredging, coordination with managing agencies, environmental testing and construction costs. Additionally, disposal of materials removed from the MOF and the access float channel during maintenance dredging events should also be considered for disposal at the DMPAs along the SNWW. The remaining options, disposal of initial dredged material via BU at the WMA and offshore disposal at the ODMDs were removed from consideration based on this assessment.

Disposal via BU at the WMA is not considered feasible, as the expected new work dredged sediment type is primarily clay, which is not suitable for disposal placement at this location. Disposal of maintenance dredged material at the WMA may be feasible, although final determination will depend on the sediment characteristics of the dredged material and will be evaluated prior to future maintenance dredging events.

Offshore disposal at an ODMDs, while technically feasible, was removed from further consideration due to high costs, with probable construction costs two to three times that of disposal at a contained upland DMPA using hydraulic cutterhead dredges. Additionally, using this option for disposal would provide for concerns regarding the feasibility of obtaining environmental permits for disposal of fine grained materials (clays and silts) and the potential effects to nearby beaches.

A summary of the evaluation and recommendations for further development for each alternative is provided in **Table 4.1**.

Table 4.1 Disposal/Reuse Options Summary					
Disposal Option	Management	Probable Method Summary	Advantages	Disadvantages/Concerns	Further Evaluation Recommended
PA-8	USACE	Hydraulic dredging to existing confined disposal area	<ul style="list-style-type: none"> <li>• Close proximity to confined disposal area</li> <li>• Cost effective and time efficient</li> <li>• Required dredging equipment readily available</li> <li>• Possible onsite reuse of material</li> </ul>	<ul style="list-style-type: none"> <li>• Subject to permissions from USACE based on capacity of site.</li> <li>• Environmental testing will be required for contaminated sediments.</li> <li>• Disposal fees required.</li> </ul>	Yes
PA-9	USACE				
ODMDS (1-4)	USACE	Mechanical dredging with hopper barge transport to offshore disposal sites	<ul style="list-style-type: none"> <li>• Permissions to use upland DMPAs not required.</li> <li>• Offshore disposal areas may have less volume restrictions for dredged material placed.</li> </ul>	<ul style="list-style-type: none"> <li>• Relatively slow production compared hydraulic dredging requiring specialized equipment that may not be common in region.</li> <li>• Poor cost effectiveness. Construction cost 3-4 times that of hydraulic dredging</li> <li>• Environmental testing and beach compatibility concerns</li> </ul>	No
J.D. Murphree WMA	TPWD	Hydraulic dredging to nearby WMA	Not feasible for initial dredging due to expected incompatible dredged sediments. Disposal for maintenance dredged material to be evaluated prior to maintenance dredging event		Not for initial dredging

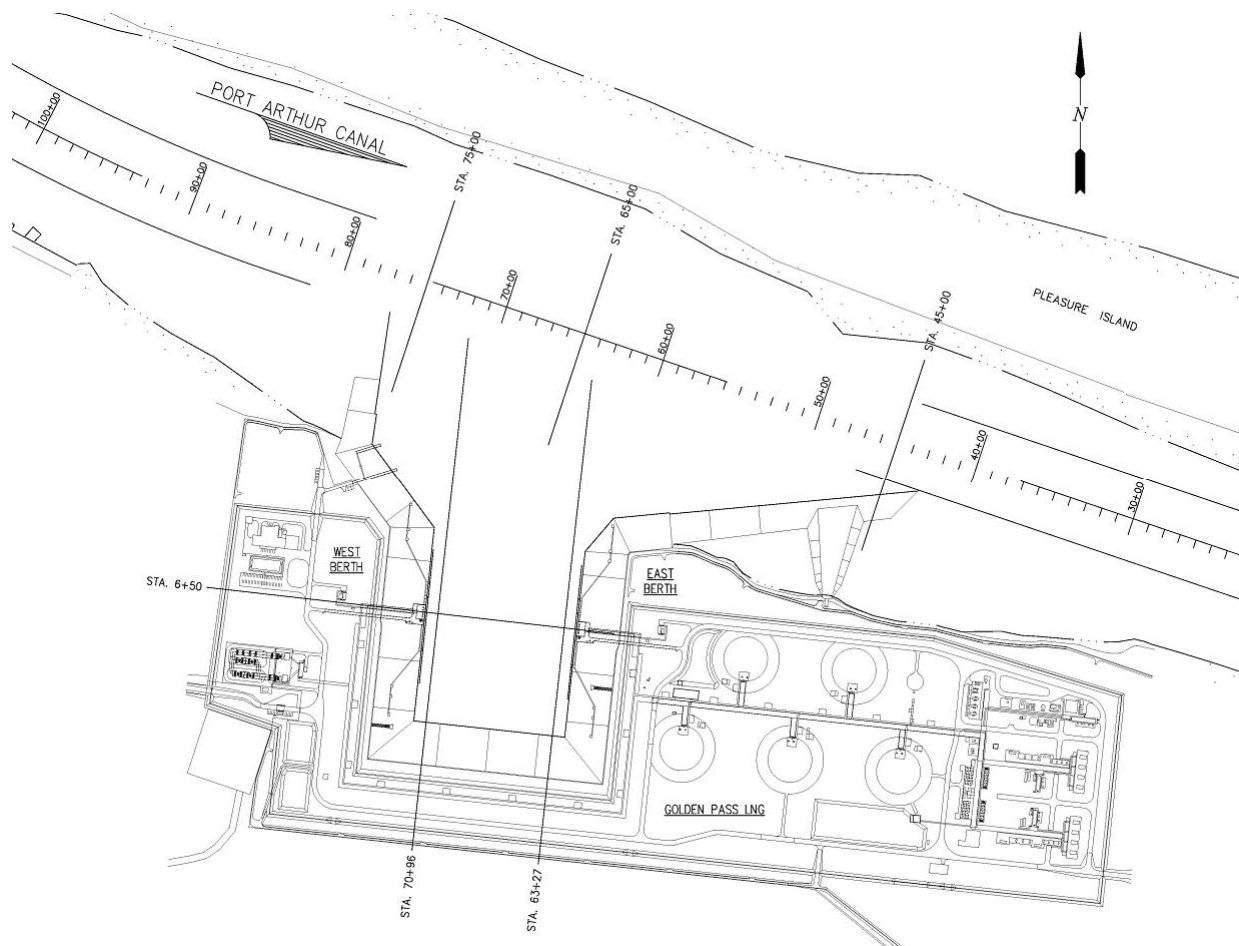


## Appendix A

### *July 2015 Bathymetry Survey Basin Condition Report*

# Golden Pass LNG Marine Terminal Sabine Pass, Texas

## BI-ANNUAL HYDROGRAPHIC SURVEY BASIN CONDITION REPORT



**July 21, 2015**

**Prepared By:**  
**LANIER & ASSOCIATES**  
**CONSULTING ENGINEERS, INC**

Texas Firm # F-2981  
595 Orleans Street  
Beaumont, TX 77701  
(409) 212-1051

**Job No. 9723**

## Survey Summary and Results

At the request of Golden Pass LNG (GPLNG), Lanier & Associates Consulting Engineers, Inc. (Lanier) performed a dual frequency hydrographic survey of the Ship Basin, Tug Dock, and Turning Basin on July 14<sup>th</sup>, 2015. As requested by GPLNG, the PAC ship channel was not included in these efforts. Following the survey, the collected data was post processed to create the following products:

- Cross sections of the ship basin and turning basin
- Calculated volumes of material above the permitted basin dredge template
- Bathymetric map of the basin and ship channel high frequency survey depths
- Bathymetric map of the depth difference from the January 2015 Lanier high frequency survey to the July 2015 Lanier high frequency survey
- Bathymetric map of the basin and ship channel low frequency survey depths
- Bathymetric map of the depth difference from the January 2015 Lanier low frequency survey to the July 2015 Lanier low frequency survey

The detailed results from the multiple final products follow.

### **Basin Results:**

Volume of accumulated material, as calculated from the high frequency survey data, above the design template (EL. -45.5 ft MLT) without side slopes is approximately 2,117,000 cubic yards.

- 628,300 CY in the ship basin Sta. 0+00 to Sta. 11+14 (Ship Basin)
- 1,488,700 CY in the turning basin and tug docks Sta. 11+14 to Sta. 24+18 (Turning Basin & Tug Docks)

<b>Ship &amp; Turning Basin</b>	<b>High Frequency</b>	<b>Low Frequency</b>
Minimum Depth	(-)20.8 Ft	(-)21.5 Ft
Average Depth	(-)28.2 Ft	(-)29.0 Ft
Maximum Depth	(-)39.0 Ft	(-)39.6 Ft

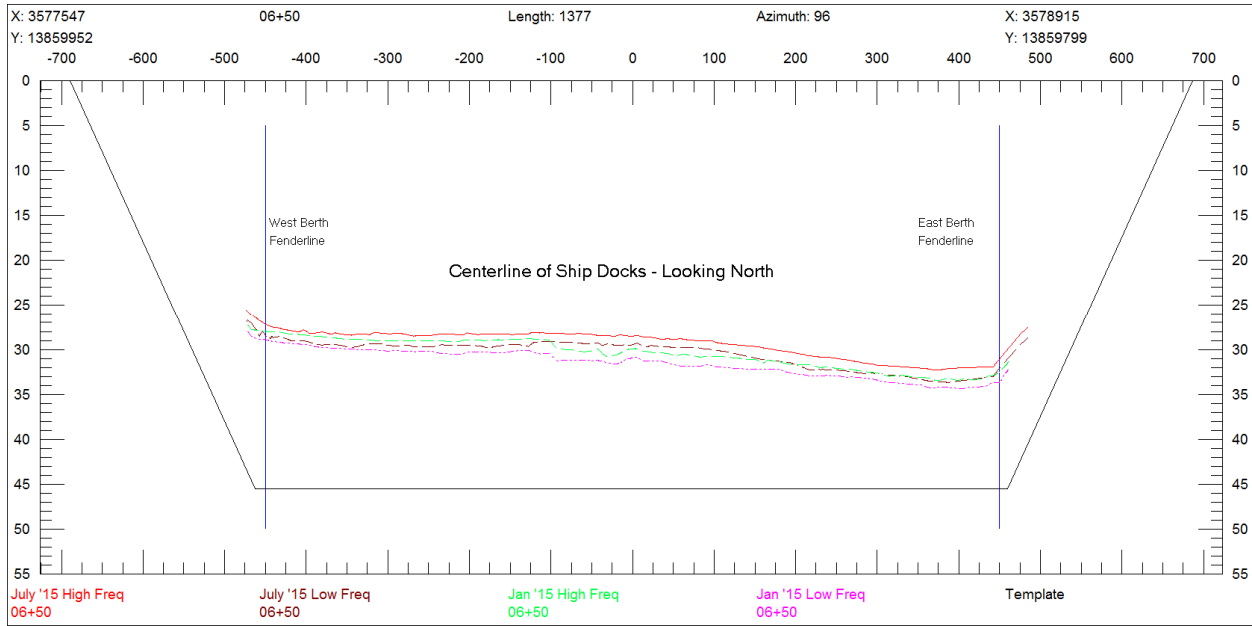
Above depths exclude soundings collected on the basin side slopes.

Average depth differential between the Lanier January 2015 high frequency survey and the Lanier July 2015 high frequency survey is approximately (+)1.0 ft.

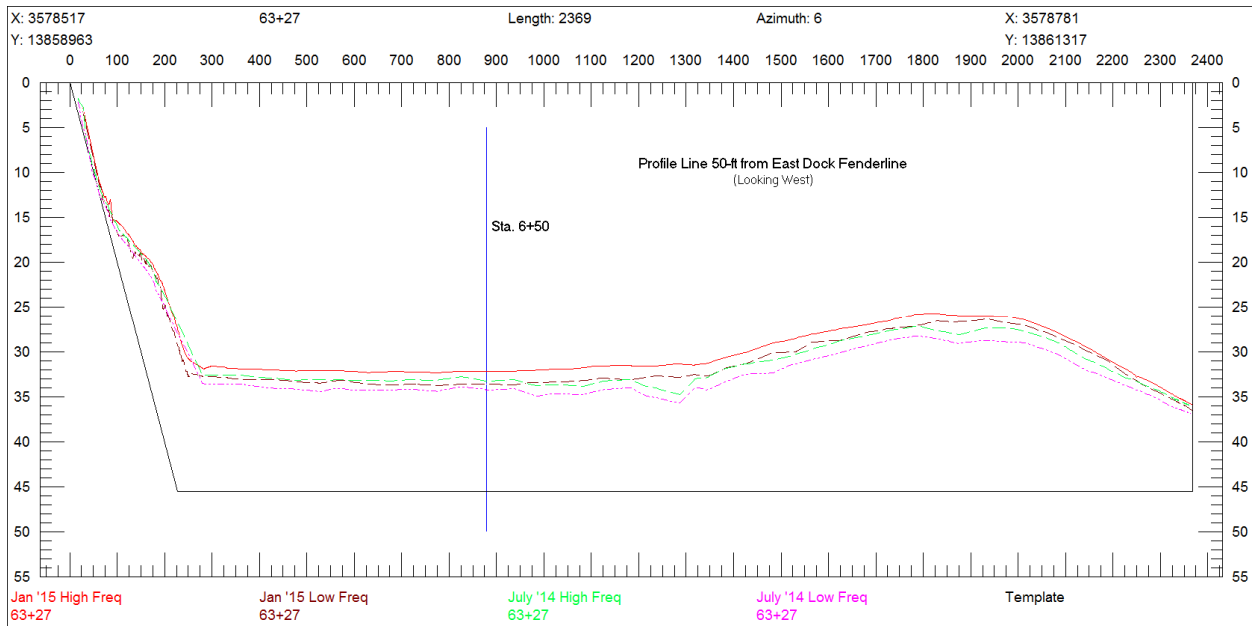
Below are sections of the basin (All cross sections are available upon request)



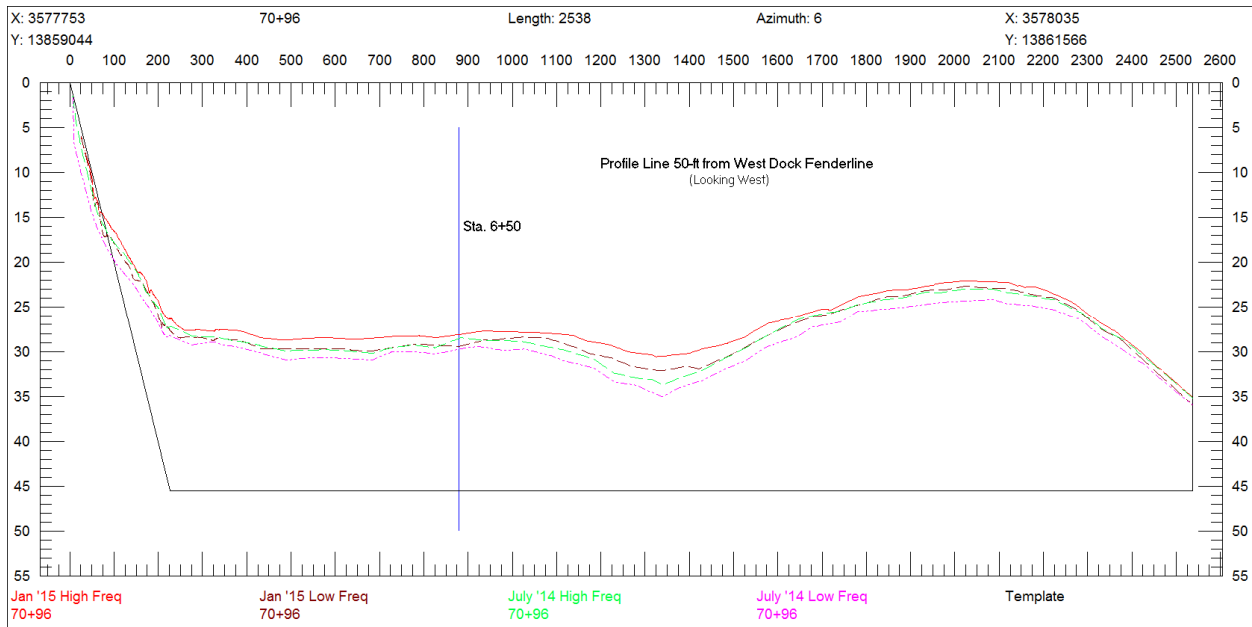
### Station 6+50 (Centerline of Ship Docks – Looking North)



### Station 63+27 (Profile Line 50-ft from East Dock Fenderline – Looking West)



### Station 70+96 (Profile Line 50-ft from West Dock Fenderline – Looking West)



## Drawings

### High Frequency Basin and Channel Bathymetric Maps: (Full Size Image Attached at end of the Report)





### High Frequency Depth Difference Bathymetric Map: (Full Size Image Attached at end of the Report)



### Low Frequency Basin and Channel Bathymetric Maps: (Full Size Image Attached at end of the Report)



**Low Frequency Depth Difference Bathymetric Map:**  
 (Full Size Image Attached at end of the Report)



## Equipment and Survey Logs

### **Horizontal Datum:**

Texas state plane coordinate system: Texas South Central (TX-4204) North American Datum 1983 (NAD 83)

### **Vertical Datum:**

All elevations are in U.S. survey feet and referenced to Mean Low Tide (MLT). A previously installed tide staff was used. The approximate location is:

- 1) Walter Umphrey State Park - Northing 13,859,743.1 and Easting 3,586,557.5

### **Equipment:**

#### **Horizontal Positioning:**

Horizontal positioning for the hydrographic survey was determined using a Raven Invicta 210 differential GPS positioning system.

#### **Fathometer:**

The depth soundings were measured with an Odom CV200 Dual Frequency Fathometer, operating at 200 kHz (high frequency) and 24 kHz (low frequency)

#### **Data Collection System:**

Data collection and processing was done using a laptop PC with Hypack Hydrographic Survey Software. HYPACK allows for the time synchronization of the collected horizontal positioning and vertical depth soundings.

#### **Vessel:**

The hydrographic survey was performed in the Miss Logan; a 20' aluminum hull boat with a through hull transducer well.

### **Survey Log Tables:**

Date:	07/14/2015	Operator:	Paul Chatagnier	L&A Project No.	
Weather:	Windy 91°	Technician:	Jason Prunty	9723	
Sound Velocity:	5019	Draft High:	1.4	Index H:	0.4
Staff Tide:	Time	Draft Low:	1.4	Index L:	0.4
2.5	1205	Notes:  Sound velocity established by CastAway CTD Tide read from reference mark on East Dock pile			
2.6	1334				
2.5	1436				
2.5	1546				
2.3	1654				
1.8	1814				
1.5	1927				

Ship Basin & Turning Basin  
High Frequency Bathymetric Map

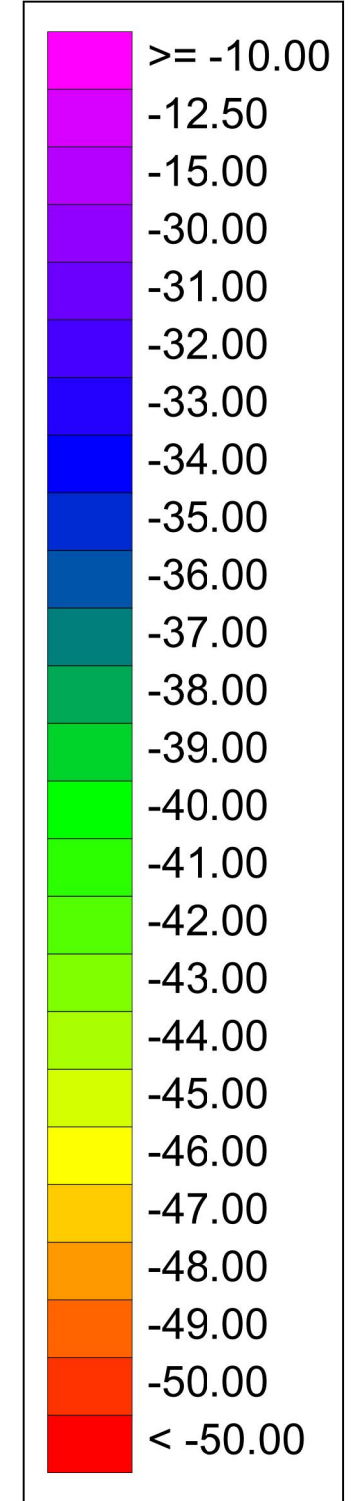
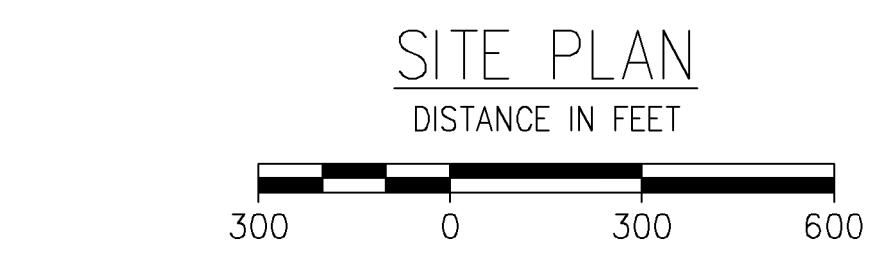






**NOTES:**

1. HYDROGRAPHIC SURVEY PERFORMED BY LANIER & ASSOCIATES ON 14 JULY 2015.
2. HORIZONTAL DATUM REFERENCED TO TEXAS STATE PLANE (SOUTH CENTRAL) NAD 83.
3. HYDROGRAPHIC SURVEY WAS PERFORMED UTILIZING ELECTRONIC POSITIONING AND DEPTH EQUIPMENT.
4. ALL ELEVATIONS ARE EXPRESSED IN FEET AND TENTHS AND ARE REFERENCED TO MEAN LOW TIDE (M.L.T.)
5. DATUM FOR THE WATER SURFACE AT THE TIME OF THE SURVEY WAS PROVIDED BY A TIDE GAGE LOCATED AT:  
N: 13860011.5 E: 3577799.5
6. THE AREA SHOWN ON THIS DRAWING IS SUBJECT TO SILTING. THE ACTUAL ELEVATIONS FOLLOWING THE DATE OF THE SURVEY MAY DIFFER FROM THE ELEVATIONS SHOWN.



**LANIER & ASSOCIATES**  
CONSULTING ENGINEERS  
INCORPORATED  
F-2981  
NEW ORLEANS, LA • BEAUMONT, TX

THIS DESIGN AND DRAWING IS THE EXCLUSIVE PROPERTY OF LANIER AND ASSOCIATES CONSULTING ENGINEERS, INC., REPRODUCTION OF THIS DRAWING IN WHOLE OR IN PART WITHOUT THE WRITTEN CONSENT OF LANIER AND ASSOCIATES IS EXPRESSLY FORBIDDEN.

REV.	DATE	BY	DESCRIPTION
A	07/21/15	JEL	ISSUED FOR REVIEW

THIS PLAN HAS BEEN PREPARED UNDER MY CLOSE PERSONAL SUPERVISION. TO THE BEST OF MY KNOWLEDGE IT COMPLIES WITH ALL REQUIREMENTS.

DATE	JULY '15
SCALE	NOTED
DESIGN	PJC
DRAWN	PJC
CHECK	JEL
APP'D	JKL
CAD	NO 15-07-C1

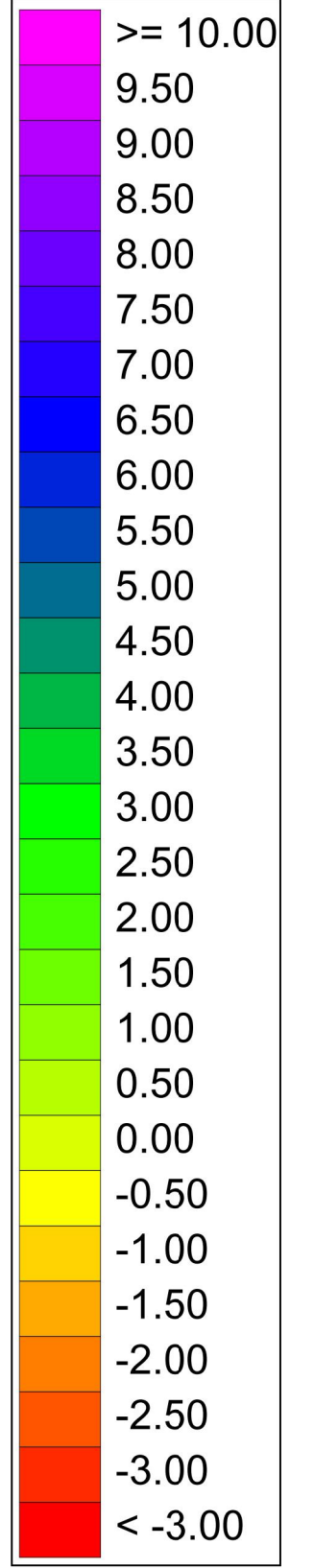
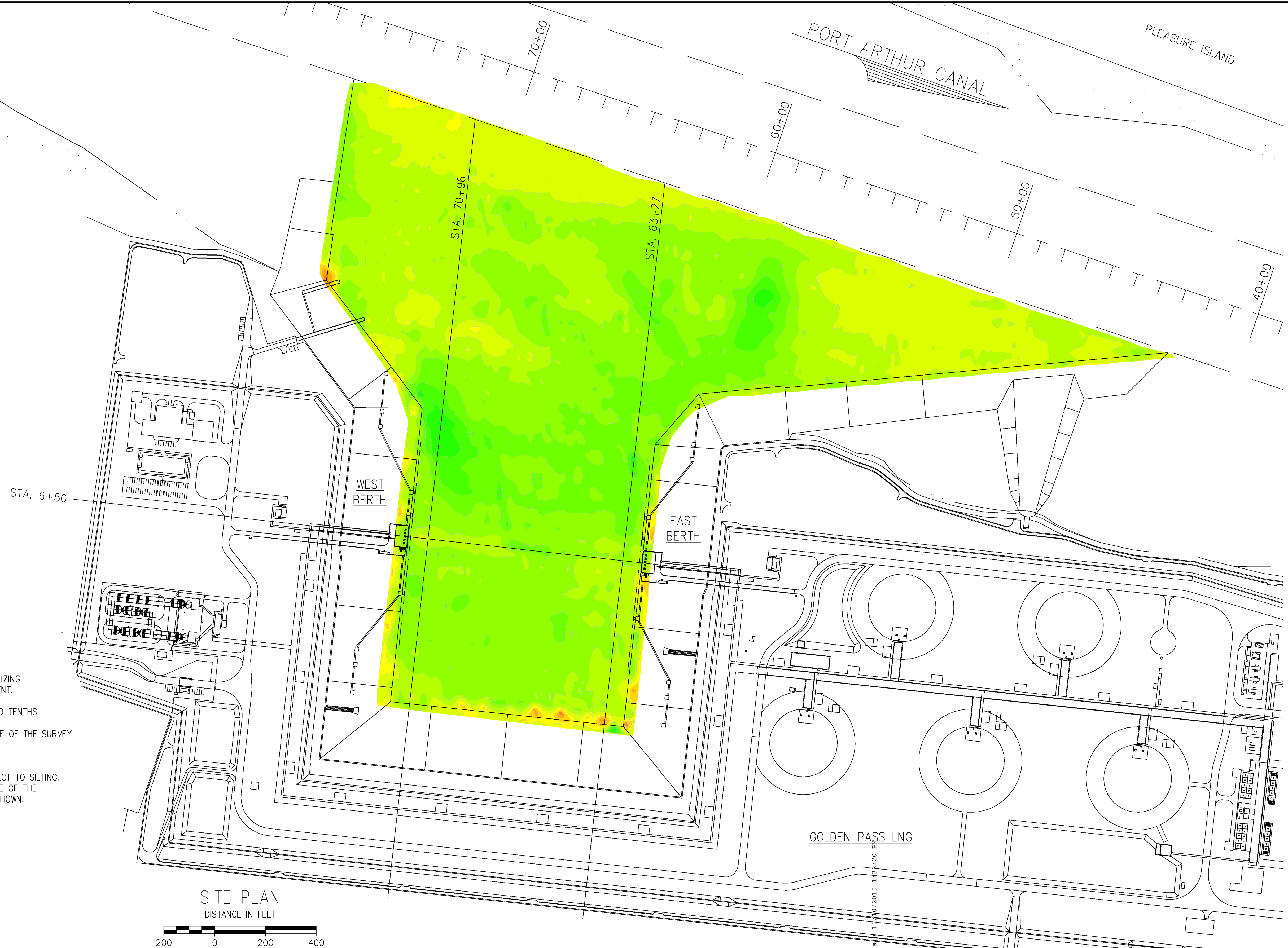
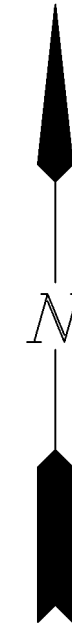
**GOLDEN PASS LNG**  
PORT ARTHUR TEXAS  
**HYDROGRAPHIC SURVEY**  
**JULY 14, 2015**  
**HIGH FREQUENCY**

SHEET NO.  
9723-15  
**C1**

Basin Depth Difference  
High Frequency Bathymetric Map







**NOTES:**

1. HYDROGRAPHIC SURVEY PERFORMED BY LANIER & ASSOCIATES ON 14 JULY 2015.
2. HORIZONTAL DATUM REFERENCED TO TEXAS STATE PLANE (SOUTH CENTRAL) NAD 83.
3. HYDROGRAPHIC SURVEY WAS PERFORMED UTILIZING ELECTRONIC POSITIONING AND DEPTH EQUIPMENT.
4. ALL ELEVATIONS ARE EXPRESSED IN FEET AND TENTHS
5. DATUM FOR THE WATER SURFACE AT THE TIME OF THE SURVEY WAS PROVIDED BY A TIDE GAGE LOCATED AT:  
N: 13860011.5 E: 3577799.5
6. THE AREA SHOWN ON THIS DRAWING IS SUBJECT TO SILTING. THE ACTUAL ELEVATIONS FOLLOWING THE DATE OF THE SURVEY MAY DIFFER FROM THE ELEVATIONS SHOWN.

**SITE PLAN**  
DISTANCE IN FEET



**LANIER & ASSOCIATES**  
CONSULTING ENGINEERS  
INCORPORATED  
F-2981  
NEW ORLEANS, LA • BEAUMONT, TX

THIS DESIGN AND DRAWING IS THE EXCLUSIVE PROPERTY OF LANIER AND ASSOCIATES CONSULTING ENGINEERS, INC., REPRODUCTION OF THIS DRAWING IN WHOLE OR IN PART WITHOUT THE WRITTEN CONSENT OF LANIER AND ASSOCIATES IS EXPRESSLY FORBIDDEN.

REV.	DATE	BY	DESCRIPTION
A	07/21/15	JEL	ISSUED FOR REVIEW

THIS PLAN HAS BEEN PREPARED UNDER MY CLOSE PERSONAL SUPERVISION. TO THE BEST OF MY KNOWLEDGE IT COMPLIES WITH ALL REQUIREMENTS.

DATE	JULY '15
SCALE	NOTED
DESIGN	PJC
DRAWN	PJC
CHECK	JEL
APP'D	JKL
CAD	NO 15-07-C2

**GOLDEN PASS LNG**  
PORT ARTHUR TEXAS  
**HYDROGRAPHIC SURVEY**  
**L&A JANUARY TO JULY DEPTH DIFFERENCE**  
**HIGH FREQUENCY**

SHEET NO.  
9723-15  
**C2**

Ship Basin & Turning Basin  
Low Frequency Bathymetric Map

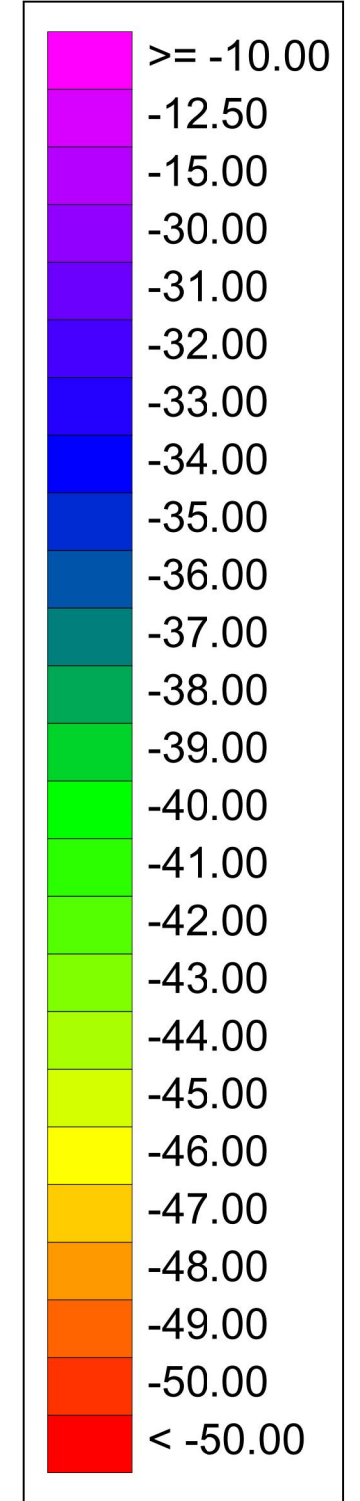






**NOTES:**

1. HYDROGRAPHIC SURVEY PERFORMED BY LANIER & ASSOCIATES ON 14 JULY 2015.
2. HORIZONTAL DATUM REFERENCED TO TEXAS STATE PLANE (SOUTH CENTRAL) NAD 83.
3. HYDROGRAPHIC SURVEY WAS PERFORMED UTILIZING ELECTRONIC POSITIONING AND DEPTH EQUIPMENT.
4. ALL ELEVATIONS ARE EXPRESSED IN FEET AND TENTHS AND ARE REFERENCED TO MEAN LOW TIDE (M.L.T.)
5. DATUM FOR THE WATER SURFACE AT THE TIME OF THE SURVEY WAS PROVIDED BY A TIDE GAGE LOCATED AT:  
N: 13860011.5 E: 3577799.5
6. THE AREA SHOWN ON THIS DRAWING IS SUBJECT TO SILTING. THE ACTUAL ELEVATIONS FOLLOWING THE DATE OF THE SURVEY MAY DIFFER FROM THE ELEVATIONS SHOWN.



**LANIER & ASSOCIATES**  
**CONSULTING ENGINEERS**  
 INCORPORATED  
 F-2981  
 NEW ORLEANS, LA • BEAUMONT, TX

THIS DESIGN AND DRAWING IS THE EXCLUSIVE PROPERTY OF LANIER AND ASSOCIATES CONSULTING ENGINEERS, INC., REPRODUCTION OF THIS DRAWING IN WHOLE OR IN PART WITHOUT THE WRITTEN CONSENT OF LANIER AND ASSOCIATES IS EXPRESSLY FORBIDDEN.

DATE	07/21/15	JEL	ISSUED FOR REVIEW
REV. DATE		BY	DESCRIPTION

THIS PLAN HAS BEEN PREPARED UNDER MY CLOSE PERSONAL SUPERVISION. TO THE BEST OF MY KNOWLEDGE IT COMPLIES WITH ALL REQUIREMENTS.

DATE	JULY '15
SCALE	NOTED
DESIGN	PJC
DRAWN	PJC
CHECK	JEL
APP'D	JKL
CAD	NO 15-07-C3

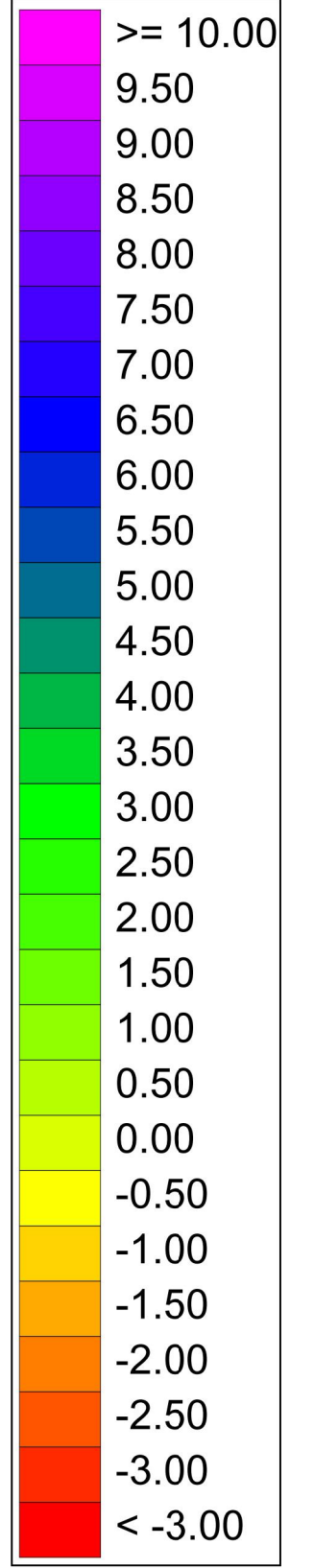
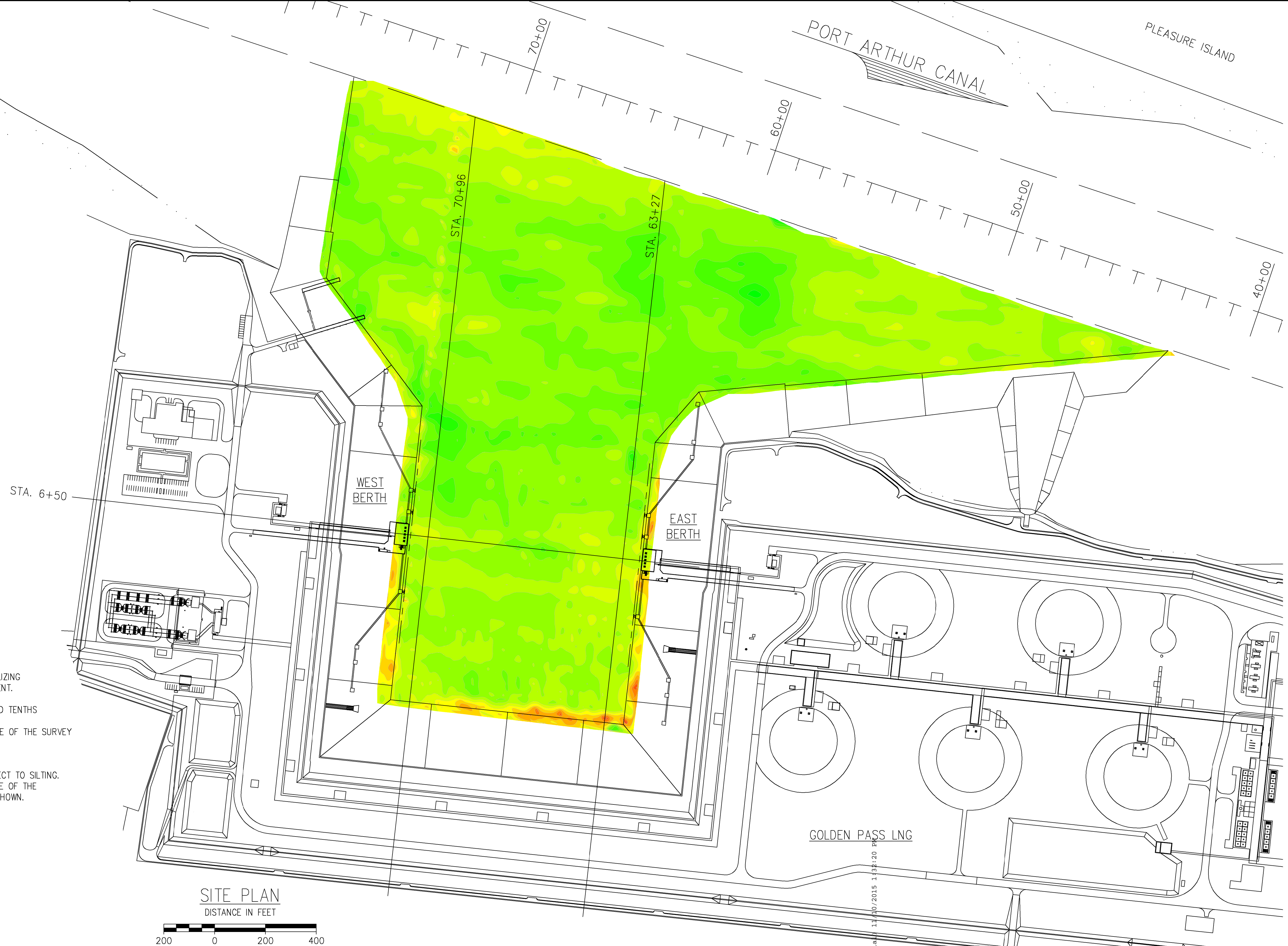
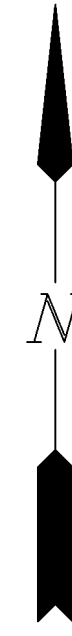
**GOLDEN PASS LNG**  
 PORT ARTHUR TEXAS  
**HYDROGRAPHIC SURVEY**  
**JULY 14, 2015**  
**LOW FREQUENCY**

SHEET NO.  
9723-15  
**C3**

Basin Depth Difference  
Low Frequency Bathymetric Map







**NOTES:**

1. HYDROGRAPHIC SURVEY PERFORMED BY LANIER & ASSOCIATES ON 14 JULY 2015.
2. HORIZONTAL DATUM REFERENCED TO TEXAS STATE PLANE (SOUTH CENTRAL) NAD 83.
3. HYDROGRAPHIC SURVEY WAS PERFORMED UTILIZING ELECTRONIC POSITIONING AND DEPTH EQUIPMENT.
4. ALL ELEVATIONS ARE EXPRESSED IN FEET AND TENTHS
5. DATUM FOR THE WATER SURFACE AT THE TIME OF THE SURVEY WAS PROVIDED BY A TIDE GAGE LOCATED AT:  
N: 13860011.5 E: 3577799.5
6. THE AREA SHOWN ON THIS DRAWING IS SUBJECT TO SILTING. THE ACTUAL ELEVATIONS FOLLOWING THE DATE OF THE SURVEY MAY DIFFER FROM THE ELEVATIONS SHOWN.

**SITE PLAN**  
DISTANCE IN FEET



**LANIER & ASSOCIATES**  
CONSULTING ENGINEERS  
INCORPORATED  
F-2981  
NEW ORLEANS, LA • BEAUMONT, TX

THIS DESIGN AND DRAWING IS THE EXCLUSIVE PROPERTY OF LANIER AND ASSOCIATES CONSULTING ENGINEERS, INC., REPRODUCTION OF THIS DRAWING IN WHOLE OR IN PART WITHOUT THE WRITTEN CONSENT OF LANIER AND ASSOCIATES IS EXPRESSLY FORBIDDEN.

REV.	DATE	BY	DESCRIPTION
A	07/21/15	JEL	ISSUED FOR REVIEW

THIS PLAN HAS BEEN PREPARED UNDER MY CLOSE PERSONAL SUPERVISION. TO THE BEST OF MY KNOWLEDGE IT COMPLIES WITH ALL REQUIREMENTS.

DATE	JULY '15
SCALE	NOTED
DESIGN	PJC
DRAWN	PJC
CHECK	JEL
APP'D	JKL
CAD	NO 15-07-C4

**GOLDEN PASS LNG**  
PORT ARTHUR TEXAS  
**HYDROGRAPHIC SURVEY**  
**L&A JANUARY TO JULY DEPTH DIFFERENCE**  
**LOW FREQUENCY**

SHEET NO.  
9723-15  
**C4**

## Basin Cross Sections



X: 3577547

06+50

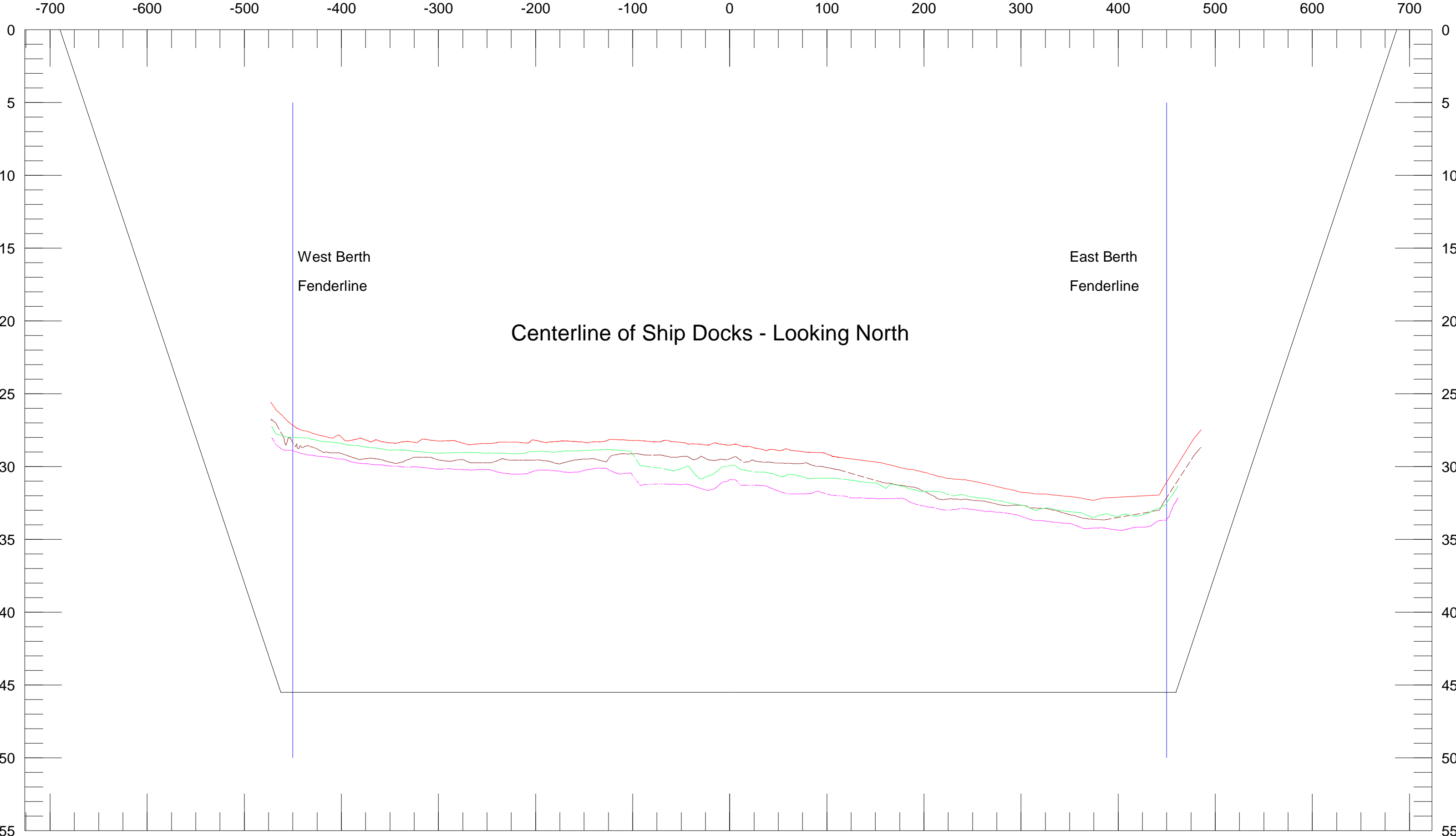
Length: 1377

Azimuth: 96

X: 3578915

Y: 13859952

Y: 13859799



### Centerline of Ship Docks - Looking North

West Berth  
Fenderline

East Berth  
Fenderline

July '15 High Freq  
06+50

July '15 Low Freq  
06+50

Jan '15 High Freq  
06+50

Jan '15 Low Freq  
06+50

Template

DBL 90 Ft:In  
Depth 6 Ft:In

X: 3578517

63+27

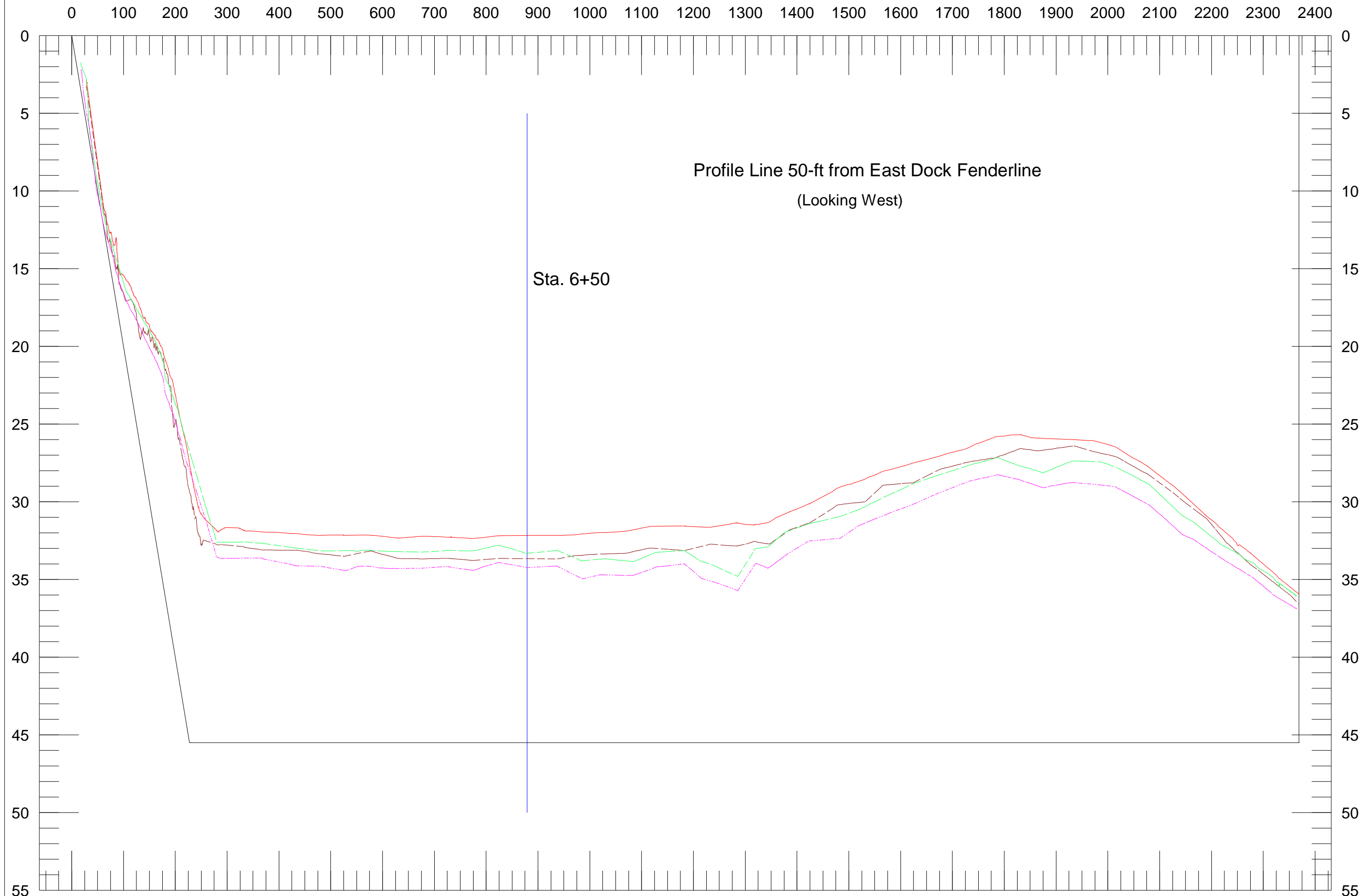
Length: 2369

Azimuth: 6

X: 3578781

Y: 13858963

Y: 13861317



Jan '15 High Freq  
63+27

Jan '15 Low Freq  
63+27

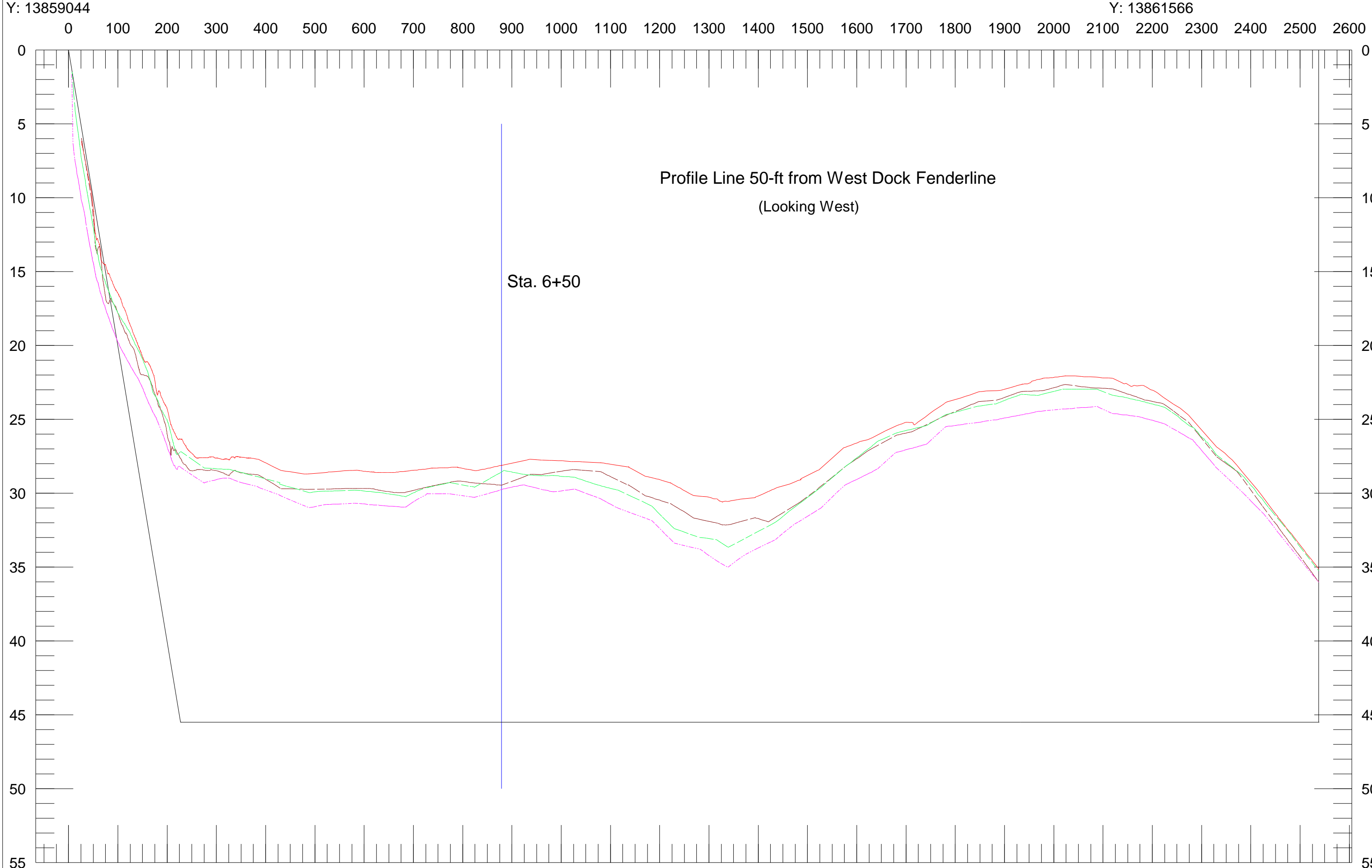
July '14 High Freq  
63+27

July '14 Low Freq  
63+27

Template

DBL 180 Ft:In  
Depth 6 Ft:In

X: 3577753 70+96 Length: 2538 Azimuth: 6 X: 3578035  
Y: 13859044 Y: 13861566



Profile Line 50-ft from West Dock Fenderline  
(Looking West)

Sta. 6+50

Jan '15 High Freq 70+96 Jan '15 Low Freq 70+96 July '14 High Freq 70+96 July '14 Low Freq 70+96 Template DBL 180 Ft:In Depth 6 Ft:In

**APPENDIX J**  
**Wetlands Associated with the Golden Pass LNG Export Project**



## APPENDIX J

## Wetland Impacts Associated with the Golden Pass Project

Project Facility	Wetland ID	Wetland Type <u>b</u>	Crossing Method	Impacts (Acres) <u>a</u>	
				Temporary	Permanent <u>c</u>
<b>TERMINAL EXPANSION</b>					
	W-006	PEM	Fill	0.1	0.1
	W-007	PEM	Fill	0.0 <u>d</u>	0.0 <u>d</u>
	W-008	PEM	Fill	0.0 <u>d</u>	0.0 <u>d</u>
	W-009	PEM	Fill	0.1	0.1
	W-010	PSS	Fill	0.1	0.1
	W-011	PEM	Fill	13.2	13.1
	W-012	PEM	Fill	0.1	0.1
	W-013	PEM	Fill	1.1	1.0
	W-014	PEM	Fill	3.8	3.5
	W-015	PEM	Fill	180.8	175.3
	W-023	PEM	Fill	0.1	0.1
	W-024	PEM	Fill	0.1	0.1
	W-025	PEM	Fill	178.2	175.6
	W-026	PEM	Fill	0.4	0.3
	W-027	PFO	Fill	0.2	0.2
	W-028	PSS	Fill	0.4	0.4
	W-029	PEM	Fill	0.0 <u>d</u>	0.0 <u>d</u>
	W-030	PEM	Fill	1.3	1.3
	W-031	PEM	Fill	0.3	0.3
	W-032	EEM	Fill	0.2	0.1
	W-033	PSS	Fill	0.7	0.7
	W-034	PFO	Fill	0.2	0.2
	W-038	PEM	Fill	0.0 <u>d</u>	0.0 <u>d</u>
<b>Terminal Expansion Subtotal</b>				<b>381.4</b>	<b>372.5</b>

**APPENDIX J**

**Wetland Impacts Associated with the Golden Pass Project**

Project Facility	Wetland ID	Wetland Type <u>b</u>	Crossing Method	Impacts (Acres) <u>a</u>	
				Temporary	Permanent <u>c</u>
<b>PIPELINE EXPANSION</b>					
<b>MP 1 Compressor Station</b>	W-013	PEM	Fill	5.6	5.6
	W-014	PEM	Fill	2.2	1.6
	W-015	PEM	Fill	0.2	0.2
<b>NGPL Interconnect (MP 1)</b>	W-014	PEM	Fill	3.5	0.1
	W-015	PEM	Fill	0.0 <u>d</u>	0.0 <u>d</u>
<b>MP 33 Compressor Station</b>	W-016	PFO	Fill	0.0 <u>d</u>	0.0 <u>d</u>
	W-019	PEM	Fill	0.1	0.1
	W-022	PEM	Fill	0.2	0.2
<b>Texoma Interconnect (MP 33)</b>	W-026	PEM	Fill	0.1	0.1
	W-028	PEM	Fill	0.0 <u>d</u>	0.0 <u>d</u>
<b>Tennessee Interconnect (MP 63)</b>	W-181	PEM	Fill	0.1	0.0 <u>d</u>
	W-182	PEM	Fill	0.0 <u>d</u>	0.0
	W-183	PEM	Fill	0.2	0.0 <u>d</u>
<b>MP 66 Compressor Station</b>	W-093	PEM	Fill	0.1	0.1
	W-094	PEM	Fill	0.0 <u>d</u>	0.0 <u>d</u>
<b>TETCO Interconnect (MP 66)</b>	W-093	PEM	Fill	0.1	0.1
<b>Calcasieu Loop</b>	W-093	PEM	HDD	0.0	0.0
	W-096	PEM	HDD	0.0	0.0
	W-098	PEM	HDD	0.0	0.0
	W-100	PEM	HDD	0.0	0.0
	W-101	PEM	HDD	0.0	0.0
	W-102	PEM	HDD	0.0	0.0
	W-103	PEM	HDD	0.0	0.0
	W-104	PEM	HDD	0.0	0.0
	W-093	PEM	Open Cut	0.0 <u>d</u>	0.0

## APPENDIX J

## Wetland Impacts Associated with the Golden Pass Project

Project Facility	Wetland ID	Wetland Type <u>b</u>	Crossing Method	Impacts (Acres) <u>a</u>	
				Temporary	Permanent <u>c</u>
	W-104	PEM	Open Cut	0.0 <u>d</u>	0.0
	W-106	PEM	Open Cut	0.1	0.0
	W-107	PEM	Open Cut	0.1	0.0
	W-108	PFO	Open Cut	0.0 <u>d</u>	0.0 <u>d</u>
	W-109	PEM	Open Cut	2.0	0.0
	W-110	PEM	Open Cut	0.1	0.0
	W-111	PEM	Open Cut	1.8	0.0
	W-112	PEM	Open Cut	0.1	0.0
	W-115	PEM	Open Cut	0.0 <u>d</u>	0.0
	W-117	PEM	Open Cut	0.1	0.0
	W-118	PSS	Open Cut	0.1	0.0
	W-119	PEM	Open Cut	0.0 <u>d</u>	0.0
	W-123	PFO	Open Cut	0.0 <u>d</u>	0.0
	W-124	PSS	Open Cut	0.0 <u>d</u>	0.0
	W-125	PEM	Open Cut	0.0 <u>d</u>	0.0
	W-127	PEM	Open Cut	0.0 <u>d</u>	0.0
	W-152	PEM	Open Cut	0.0 <u>d</u>	0.0
	Aerial Imagery Interpretation <u>e</u>	PEM	Open Cut	0.2	0.0
<b>Transco Interconnect (MP 68)</b>	NA	NA	NA	0.0	0.0
<b>Pipeline Expansion Subtotal</b>				<b>17</b>	<b>8.2</b>
<b>PROJECT TOTAL</b>				<b>398.4</b>	<b>380.7</b>

a Includes impacts associated with access roads and ATWS.  
b PEM wetlands include PEMf (farmed) and PEMx (excavated) wetlands. PFO wetlands include PFOx (excavated) wetlands.  
c Temporary impacts are included in the permanent impacts.  
d Impacts would occur, but they would be on 0.044 acre or less.  
e Survey access was not available for the parcel on which this wetland is located during the time of surveys. Therefore, wetlands were delineated based on a review of 2014 aerial imagery.

**APPENDIX K**  
**Bird Strike Monitoring Plan**



# GPLNG Terminal Bird Strike Monitoring Plan September 10, 2014

Monitoring Period: Weekly During March 1 - May 15 and  
Weekly During July 15 - October 31  
Monitoring Requirements Cease 6 months after Export  
Terminal In-Service

Monitoring Locations / Station ID: From the base of below structures outward to  
approximately 30 feet:

1. Bypass Stack MR Compressor Gas Turbine Train 1
2. Bypass Stack MR Compressor Gas Turbine Train 2
3. Bypass Stack MR Compressor Gas Turbine Train 3
4. Bypass Stack Propane Compressor Gas Turbine Train 1
5. Bypass Stack Propane Compressor Gas Turbine Train 2
6. Bypass Stack Propane Compressor Gas Turbine Train 3
7. Heat Recovery Steam Generator Train 1
8. Heat Recovery Steam Generator Startup Train 1 – MSS
9. Heat Recovery Steam Generator Train 2
10. Heat Recovery Steam Generator Startup Train 2 – MSS
11. Heat Recovery Steam Generator Train 3
12. Heat Recovery Steam Generator Startup Train 3 – MSS
13. Heat Recovery Steam Generator Train 1
14. Heat Recovery Steam Generator Startup Train 1 – MSS
15. Heat Recovery Steam Generator Train 2
16. Heat Recovery Steam Generator Startup Train 2 – MSS
17. Heat Recovery Steam Generator Train 3
18. Heat Recovery Steam Generator Startup Train 3 - MSS

- 1) During the monitoring period, GPLNG is to observe monitoring locations within four (4- 6) hours after sunrise.
- 2) Monitoring includes observation for dead or injured birds.
- 3) After observing the monitoring location(s), the GPLNG will complete the following sections of Attachment A-3 included in attached "Bird Strike Monitoring Plan":
  - **Date**
  - **Time**
  - **Person Completing Form**

- **Station I.D.** –
- **Species** – if known

- 4) Dead birds will be disposed of with general industrial waste unless not allowed by transporter or landfill; otherwise, GPLNG will find an alternative appropriate means of disposal.
- 5) Injured birds will be transported to nearest approved wildlife rehabilitation center. Visually uninjured birds will be left alone.
- 6) Monitoring data will be reported to the FERC and USFWS within 60 days of the completion of monitoring, following 6 months post facility in service date during facility operation.

**Attachment A-1**  
**Bird Strike Monitoring Station ID Characterization Form**

Station ID	Location (Lat/Long)	Structure Type (Tank, Vent Pipe, etc)	Structure Color
1	STACK		
2	STACK		
3	STACK		
4	STACK		
5	STACK		
6	STACK		
7	STACK		
8	STACK		
9	STACK		
10	STACK		
11	STACK		
12	STACK		
13	STACK		
14	STACK		
15	STACK		
16	STACK		
17	STACK		
18	STACK		

## Attachment A-2 Bird Strike Monitoring Data Collection Form

Date: \_\_\_\_\_ Time: \_\_\_\_\_ AM/PM (circle one)

Person Completing Form: \_\_\_\_\_

Species	Station ID	Specimen Condition			Comments (include nature of injuries and relative location bird was found within station ID)	Specimen Disposition		
		Stunned	Visibly Injured	Dead		Released	Destroyed	Transferred

Contact information of person visually injured bird was transferred to: \_\_\_\_\_

Contact information of person dead bird was transferred to for proper disposal: \_\_\_\_\_

Other Comments: \_\_\_\_\_

\_\_\_\_\_

\_\_\_\_\_

\_\_\_\_\_



**APPENDIX L**  
**References**

## APPENDIX L – REFERENCES

- ABS Consulting (ABSC). 2004. Risk Consulting Division, “Seismic Hazard Assessment of the Golden Pass LNG Terminal Site, Texas,” ExxonMobil Development Company, Golden Pass, Sabine, Texas.
- Alpine Geophysics, LLC (AG). 2011. Ozone Impact Analysis of the Proposed Cheniere Sabine Pass Liquefaction Facility, prepared by Dennis McNally and Cyndi Loomis, March 24, 2011.
- American Hospital Directory. 2012. Available at: [http://www.ahd.com/states/hospital\\_LA.html](http://www.ahd.com/states/hospital_LA.html). Accessed: September 28, 2014.
- American Industrial Hygiene Association. 2013. ERPG/WEEL Handbook. Available at: <http://www.aiha.org/get-involved/AIHAGuidelineFoundation/EmergencyResponsePlanningGuidelines>. Accessed: August 24, 2015.
- Ashworth, J. B. and J. Hopkins. 1995. Aquifers of Texas. (Texas Water Development Board Report 345.) 63 pp.
- Association of State Wetland Managers (ASWM). 2011. 401 Certification Program Summary – Louisiana. Available at: [http://www.aswm.org/~aswm/pdf\\_lib/401\\_cert/louisiana\\_case\\_study.pdf](http://www.aswm.org/~aswm/pdf_lib/401_cert/louisiana_case_study.pdf). Accessed September 23, 2014.
- Audubon. 2014a. Central Flyway. Available at: <http://conservation.audubon.org/central-flyway>. Accessed July 2014.
- Audubon. 2014b. Mississippi Flyway. Available at: <http://conservation.audubon.org/mississippi-flyway>. Accessed July 2014.
- Audubon. 2014c. Atlantic Flyway. Available at: <http://conservation.audubon.org/atlantic-flyway>. Accessed July 2014.
- Audubon. 2014d. Reddish Egret. Available at: <http://birds.audubon.org/species/redegr>. Accessed July 2014.
- Audubon. 2014e. Swallow-tailed Kite. Available at: <http://birds.audubon.org/species/swakit>. Accessed July 2014.
- Audubon. 2014f. White-faced Ibis. Available at: <http://birds.audubon.org/species/whiibi2>. Accessed July 2014.
- Audubon. 2014g. Wood Stork. Available at: <http://birds.audubon.org/species/woosto>. Accessed July 2014.
- Bates, R. L. and J. A. Jackson. 1984. Dictionary of Geological Terms, 3rd Edition. Anchor Books, New York.
- Benchmark Ecological Services, Inc. (BES). 2013a. Golden Pass LNG Export Terminal – GPX Project Wetland Determination Report, Jefferson County, Texas.
- Benchmark Ecological Services, Inc. (BES). 2013b. GPX Pipeline – GPX Project Wetland Determination Report, Orange County, Texas and Calcasieu Parish, Louisiana.

## APPENDIX L – REFERENCES

- Benchmark Ecological Services, Inc. (BES). 2013c. Golden Pass LNG Export Terminal – GPX Project Threatened and Endangered Species Evaluation – DRAFT Jefferson County, Texas.
- Benchmark Ecological Services, Inc. (BES). 2013d. GPX Pipeline – GPX Project Threatened and Endangered Species Evaluation, Orange County, Texas and Calcasieu Parish, Louisiana.
- Benchmark Ecological Services, Inc. (BES). 2015. Sediment Sampling and Analysis Report – Golden Pass Products LNG Terminal Ship Slip, Sabine Pass, Texas. Prepared for Golden Pass Products LLC & Golden Pass Pipeline LLC. On behalf of: exp Energy Services, Inc. June.
- California Department of Transportation (Caltrans). 2009. Technical Noise Supplement. Available at: [http://www.dot.ca.gov/hq/env/noise/pub/tens\\_complete.pdf](http://www.dot.ca.gov/hq/env/noise/pub/tens_complete.pdf).
- Caswell, S. J., and J. Jakus. (Caswell and Jakus). 1977. Role of Land Use Planning in Noise Control. Available at: <http://www.treesearch.fs.fed.us/pubs/11556>.
- Cheniere Energy Partners (Cheniere Energy). 2014. Cheniere and EDF Sign 20-Year LNG Sale and Purchase Agreement. Available at: <http://phx.corporate-ir.net/phoenix.zhtml?c=101667&p=irol-newsArticle&ID=1948639&highlight=>. Accessed July 2014.
- Chicago Bridge & Iron Company (CB&I). 2014. GPX Terminal Noise Report, Revision A. March 27.
- Chowdhury, A. H., and M. Turco. 2006. Geology of the Gulf Coast Aquifer, Texas. Chapter 2 of Texas Water Development Board Report 365. Aquifers of the Gulf Coast of Texas. February.. Available at: [http://www.twdb.state.tx.us/publications/reports/numbered\\_reports/doc/R365/R365\\_Composite.pdf](http://www.twdb.state.tx.us/publications/reports/numbered_reports/doc/R365/R365_Composite.pdf). Accessed August 5, 2014.
- City of Port Arthur (CPA). 2012. Port Arthur Annual Water Quality Report. Reporting Year 2012. Available at: <http://www.portarthur.net/page.cfm?id=47>. Accessed August 5, 2014.
- Cornell University. 2011a. The Cornell Lab of Ornithology, All about Birds. Available at: <http://www.allaboutbirds.org/Page.aspx?pid=1189>. Accessed July 2014.
- Cornell University. 2011b. The Cornell Lab of Ornithology, All about Birds: Piping Plover. Available at: [http://www.allaboutbirds.org/guide/piping\\_plover/id](http://www.allaboutbirds.org/guide/piping_plover/id). Accessed July 2014.
- Council on Environmental Quality (CEQ). 1997a. Environmental Justice, Guidance under the National Environmental Policy Act. Executive Office of the President, Washington, DC.
- Council on Environmental Quality (CEQ). 1997b. Considering Cumulative Effects under the Environmental Policy Act. January.
- Council on Environmental Quality (CEQ). 2005. Guidance on the Consideration of Past Actions in Cumulative Effects Analysis. Memorandum from J. L. Connaughton, Chairman, Executive Office of the President –Council on Environmental Quality. June 24.
- Council on Environmental Quality (CEQ). 2014. Revised Draft Guidance for Federal Departments and Agencies on Consideration of Greenhouse Gas Emissions and the Effects of Climate Change in NEPA Reviews. Federal Register 77802 (Volume 79, No. 247.) December 24.

## APPENDIX L – REFERENCES

- Cowardin, L. M., V. Carter, F. C. Golet, and E. T. LaRoe. 1979. Classification of Wetlands and Deepwater Habitats of the United States. U.S. Fish and Wildlife Service, Washington, D.C.
- Dokka, R. K., K. Shinkle, and J. Heltz. 2003. Major Subsidence of the Modern Louisiana Coast. Geological Society of America Abstracts with Programs. Geological Society of America, Boulder, Colorado.
- Dow Piniak, W. E., D. A. Mann, T. T. Jones, S. A. Eckert, and C. A. Harms. 2014a. In-water and In-air Hearing Sensitivity of the Juvenile Green Sea Turtle (*Chelonia mydas*). 34<sup>th</sup> Annual Symposium on Sea Turtle Biology and Conservation, New Orleans, Louisiana.
- Dow Piniak, W. E., S. A. Eckert, D. A. Mann, and J. A. Horrocks. 2014b. Amphibious Hearing in Hatchling Hawksbill Sea Turtles (*Eretmochelys imbricata*). 34<sup>th</sup> Annual Symposium on Sea Turtle Biology and Conservation, New Orleans, LA.
- Environmental Laboratory. 1987. Corps of Engineers Wetlands Delineation Manual. (Technical Report Y-87-1.) U.S. Army Engineer Waterways Experiment Station, Vicksburg, Mississippi.
- Federal Emergency Management Agency (FEMA). 2013. Map Service Center. Available at: <https://msc.fema.gov/webapp/wcs/stores/servlet/FemaWelcomeView?storeId=10001&catalogId=10001&langId=-1>. Accessed July 2014.
- Federal Energy Regulatory Commission (FERC). 2005. Final Environmental Impact Statement, Golden Pass LNG Terminal and Pipeline Project: Golden Pass LNG Terminal L.P., Golden Pass Pipeline, L.P. Federal Energy Regulatory Commission. Office of Energy Projects, Washington, D.C. Docket No. CP04-386-000, Docket Nos. CP04-400-000, CP04-401-000, CP04-402-000. FERC/EIS-0180F. June 2005. Available at: [http://elibrary.ferc.gov/idmws/File\\_list.asp?document\\_id=4309499](http://elibrary.ferc.gov/idmws/File_list.asp?document_id=4309499). Accessed July 2014.
- Federal Transit Administration (FTA). 2006. Transit Noise and Vibration Impact Assessment. (FTA-VA-90-1003-06.) Available at: [http://www.fta.dot.gov/documents/FTA\\_Noise\\_and\\_Vibration\\_Manual.pdf](http://www.fta.dot.gov/documents/FTA_Noise_and_Vibration_Manual.pdf).
- Fossilworks. 2013. The Paleobiology Database. Available at: <http://fossilworks.org/bridge.pl>. Accessed July 2014.
- Fugro Consultants, Inc. (Fugro). 2004. Geotechnical Study: LNG Tanks. ExxonMobil Development Company, Sabine Pass, Texas. (Report No. 0415-0963-1.) March 22.
- Fugro Consultants, Inc. (Fugro). 2007a. Geotechnical Study: Ship Slip Slope Stability Analysis. Chicago Bridge and Iron Company, Sabine Pass, Texas. (Report No. 0415-1548-1.)
- Fugro Consultants, Inc. (Fugro). 2007b. Geotechnical Study: Ship Slip Slope Stability Analysis. Chicago Bridge and Iron Company, Sabine Pass, Texas. (Report No. 0415-1548-2.)
- Fugro Consultants, Inc. (Fugro). 2013. Pre-FEED Level Geotechnical Study. ExxonMobil Development Company, Sabine Pass, Texas. (Report No. 04.10120315-2.) July 26.
- Fugro Consultants, Inc. (Fugro). 2014a. Detailed Geotechnical Study, Golden Pass LNG Export Facility. Golden Pass Products, LLC, Sabine Pass, Texas. (Report No. 04. 10140035.) September 17.

## APPENDIX L – REFERENCES

- Fugro Consultants, Inc. (Fugro). 2014b. Seismic Hazard Assessment. Golden Pass LNG Export Facility. Golden Pass Products LLC, Sabine Pass, Texas. (Report No. 04. 10130245.) June 25.
- Fugro Consultants, Inc. (Fugro). 2014c. Geotechnical Fault Study. Golden Pass Products LLC, Sabine Pass, Texas. (Report No. 04. 10120315.) March 6.
- Gibeaut, J. C., W. A. White, and T. A. Tremblay. 2000. Coastal Hazards Atlas of Texas: a Tool for Hurricane Preparedness and Coastal Management Volume 1. Bureau of Economic Geology. June. Available at: [http://www.beg.utexas.edu/coastal/presentations\\_reports/hazardsatlas\\_v1\\_2000.pdf](http://www.beg.utexas.edu/coastal/presentations_reports/hazardsatlas_v1_2000.pdf). Accessed January 2014.
- Gulf of Mexico Fishery Management Council (GMFMC). 2010a. Fishery Management Plans and Amendments. Available at: [http://www.gulfcouncil.org/fishery\\_management\\_plans/index.php](http://www.gulfcouncil.org/fishery_management_plans/index.php). Accessed July 2014.
- Gulf of Mexico Fishery Management Council (GMFMC). 2010b. Final Report Gulf of Mexico Fishery Management Council – 5-Year Review of the Final Generic Amendment Number 3 Addressing Essential Fish Habitat Requirements, Habitat Areas of Particular Concern, and Adverse Effects of Fishing in the Fishery Management Plans of the Gulf of Mexico. Available at: <http://www.gulfcouncil.org/Beta/GMFMCWeb/downloads/EFH%205-Year%20Review%20Final%2010-10.pdf>. Accessed July 2014.
- Herps of Texas. 2014a. Herps of Texas. Available at: <http://www.herpssoftexas.org/>. Accessed July 2014.
- Herps of Texas. 2014b. Alligator Snapping Turtle. Available at: <http://www.herpssoftexas.org/content/alligator-snapping-turtle>. Accessed July 2014.
- Hoover and Keith (H&K). 2015. Acoustics and Noise Control Engineering, Environmental Sound Level Assessment for Flare Operation at the Golden Pass LNG Liquefaction Facility. October 6
- Hoover and Keith (H&K). 2014a. MP 1 Compressor Station for the Golden Pass Products LNG Export Project. Results of an Ambient Sound Survey & Acoustical Analyses. (Report No. 2987 Revision 5.) March 21.
- Hoover and Keith (H&K). 2014b. MP 33 Compressor Station for the Golden Pass Products LNG Export Project, Results of an Ambient Sound Survey & Acoustical Analyses. (Report No. 2988 Revision 2.) March 21.
- Hoover and Keith (H&K). 2014c. MP 66 Compressor Station for the Golden Pass Products LNG Export Project, Results of an Ambient Sound Survey & Acoustical Analyses. (Report No. 2989 Revision 4.) September 3.
- Hoover and Keith (H&K). 2014d. Calcasieu Loop HDD for the Golden Pass Products LNG Export Project, Results of an Ambient Sound Survey & Acoustical Analyses. (Report No. 2993.) March 20
- HotelsMotels.info. (2014). Hotels and Motels. Available at: <http://www.hotelmotels.info/Counties/>. Accessed September 28, 2014.

## APPENDIX L – REFERENCES

- Index Mundi. 2014a. Texas average household size, by county. Available at: <http://www.indexmundi.com/facts/united-states/quick-facts/texas/average-household-size#map>.
- Index Mundi. 2014b. Louisiana average household size, by county. Available at: <http://www.indexmundi.com/facts/united-states/quick-facts/louisiana/average-household-size#map>.
- Larson, S. C., M. J. Van Den Avyle, and E. L. Bozeman, Jr. 1989. Species profiles: life histories and environmental requirements of coastal fishes and invertebrates (South Atlantic)–brown shrimp. U.S. Fish Wildl. Serv. Biol. Rep. 82(11.90). (U.S. Army Corps of Engineers TR EL-82-4.) 14 pp. Available at: [http://www.nwrc.usgs.gov/wdb/pub/species\\_profiles/82\\_11-090.pdf](http://www.nwrc.usgs.gov/wdb/pub/species_profiles/82_11-090.pdf).
- Louisiana Administrative Code (LAC). 2012. Title 33 Environmental Quality; Part IX. Water Quality; Subpart 1. Water Pollution Control: Chapter 11. Surface Water Quality Standards. Available at: <http://water.epa.gov/scitech/swguidance/standards/upload/lawqs.pdf>. Accessed August 24, 2015.
- Louisiana Administrative Code (LAC). 2014. Title 33 Environmental Quality, Part III Air. Available at: <http://www.deq.louisiana.gov/portal/Portals/0/planning/regs/title33/33v03-201403.pdf>.
- Louisiana Department of Environmental Quality (LDEQ). 1996. 1996 305b Appendix F. Major Aquifer Systems of Louisiana. Available at: <http://www.deq.louisiana.gov/static/305b/1996/305b-f.htm>. Accessed August 4, 2014.
- Louisiana Department of Environmental Quality (LDEQ). 2003a. Baseline Monitoring Program, Fiscal Years 2001 – 2003 (June 2000 through June 2003). Triennial Summary Report, 2003 for the Environmental Technology Division of the Louisiana Department of Environmental Quality. Available at: <http://www.deq.louisiana.gov/portal/Portals/0/evaluation/aeps/Triennial%20Summary%20Report%202003.pdf>. Accessed August 5, 2014.
- Louisiana Department of Environmental Quality (LDEQ). 2003b. Chicot Aquifer Summary Baseline Monitoring Project, FY 2002 – Appendix 10 of the Triennial Summary Report, 2003. Available at: <http://www.deq.louisiana.gov/portal/PORTALS/0/evaluation/aeps/10ChicotAquiferSummary03.pdf>. Accessed August 5, 2014.
- Louisiana Department of Environmental Quality (LDEQ). 2006. Air Quality Modeling Procedures. August 2006. Available at: <http://www.deq.louisiana.gov/portal/Portals/0/permits/air/Air%20Quality%20Modeling%20Procedures.pdf>.
- Louisiana Department of Environmental Quality (LDEQ). 2014a. Drinking Water Protection Program History. Available at: <http://www.deq.louisiana.gov/portal/PROGRAMS/DrinkingWaterProtectionProgram/ProgramHistory.aspx>. Accessed August 5, 2014.
- Louisiana Department of Environmental Quality (LDEQ). 2014b. Email correspondence between Golden Pass representative and Jesse Means (LDEQ). January 17, 2014.
- Louisiana Department of Environmental Quality (LDEQ) 2014c. Ambient Air Monitoring Program. Air Monitoring Sites. Available at: <http://www.deq.louisiana.gov/portal/DIVISIONS/Assessment/AirFieldServices/AmbientAirMonitoringProgram/AirMonitoringSites.aspx>.

## APPENDIX L – REFERENCES

- Louisiana Department of Natural Resources (LDNR). 1997. Louisiana Coastal Wetlands Conservation Plan. May 1997. Available at: <http://dnr.louisiana.gov/assets/OCM/permits/CWCP.pdf>. Accessed August 6, 2014.
- Louisiana Department of Natural Resources (LDNR). 2013. SONRIS Interactive Maps – Water Wells Registration. Available at: <http://sonris-www.dnr.state.la.us/gis/agsweb/IE/JSViewer/index.html?TemplateID=181>. Accessed August 5, 2014.
- Louisiana Department of Wildlife and Fisheries (LDWF). 2013a. Louisiana Natural and Scenic Rivers Descriptions and Map. Available at: <http://www.wlf.louisiana.gov/louisiana-natural-and-scenic-rivers-descriptions-and-map>. Accessed August 5, 2014.
- Louisiana Department of Wildlife and Fisheries (LDWF). 2013b. Letter dated October 1, from Kyle Balkum, LDWF Biologist Program Manager, to Kim Bose, FERC.
- Louisiana Department of Wildlife and Fisheries (LDWF). 2014. Rare Animals Tracking List and Fact Sheets. Available at: <http://www.wlf.louisiana.gov/wildlife/rare-animals-fact-sheets>. Accessed July 2014.
- Louisiana Ground Water Resources Commission (LGWRC). 2012. Managing Louisiana’s Groundwater Resources, with Supplemental Information on Surface Water Resources. An Interim Report to the Louisiana Legislature. March 15. Available at: <http://dnr.louisiana.gov/assets/docs/conservation/groundwater/12.Final.GW.Report.pdf>. Accessed August 5, 2014.
- Louisiana State University (LSU). 2013. SURGEDAT: The World’s Storm Surge Data Center. Available at: <http://surge.srcc.lsu.edu/>. Accessed July 2014.
- Minerals Management Service (MMS). 2004. Review of Existing and Emerging Environmentally Friendly Offshore Dredging Technologies. Prepared for the Leasing Division, Sand and Gravel Unit, Minerals Management Service, U.S. Department of Interior, Herndon, Virginia. Prepared by W.F. Baird & Associates, Ltd. and Research Planning, Inc.
- Municipal Code Corporation (MCC). 2014a. Code of Ordinances. City of Port Arthur, Texas. Available at: <https://library.municode.com/index.aspx?clientId=11444>.
- Municipal Code Corporation (MCC). 2014b. Code of Ordinances. Parish of Calcasieu, Louisiana. Available at: <https://library.municode.com/index.aspx?clientId=10499>.
- Muncy, R. J. 1984. Species profiles : life histories and environmental requirements of coastal fishes and invertebrates (South Atlantic)–white shrimp. U.S. Fish Wildl. Serv. FWS/OBS-82/11.27. (U.S. Army Corps of Engineers, TR EL-82-4.) 19 pp. Available at: [http://www.nwrc.usgs.gov/wdb/pub/species\\_profiles/82\\_11-027.pdf](http://www.nwrc.usgs.gov/wdb/pub/species_profiles/82_11-027.pdf)
- National Center for Education Statistics. 2014. Search for Public Schools. Available at: <http://nces.ed.gov/ccd/schoolsearch/>. Accessed September 28, 2014.
- National Climatic Data Center (NCDC). 2010. 1981–2010 U.S. Climate Normals. Available at: <http://www.ncdc.noaa.gov/data-access/land-based-station-data/land-based-datasets/climate-normals/1981-2010-normals-data>.

## APPENDIX L – REFERENCES

- National Oceanic and Atmospheric Administration (NOAA). 2005. “Hurricane Rita”, NOAA’s National Climate Data Center, Asheville, NC. Available at: <http://www.ncdc.noaa.gov/extremeevents/specialreports/Hurricane-Rita2005.pdf>. Accessed July 2014.
- National Oceanic and Atmospheric Administration (NOAA). 2006. Sea Turtle and Smalltooth Sawfish Construction Conditions. Available at: [http://sero.nmfs.noaa.gov/protected\\_resources/section\\_7/guidance\\_docs/documents/sea\\_turtle\\_and\\_smalltooth\\_sawfish\\_construction\\_conditions\\_3-23-06.pdf](http://sero.nmfs.noaa.gov/protected_resources/section_7/guidance_docs/documents/sea_turtle_and_smalltooth_sawfish_construction_conditions_3-23-06.pdf). Accessed July 2014.
- National Oceanic and Atmospheric Administration (NOAA). 2008. Vessel Strike Avoidance Measures and Reporting for Mariners, NOAA Fisheries Service, Southeast Region. Available at: [http://sero.nmfs.noaa.gov/protected\\_resources/section\\_7/guidance\\_docs/documents/copy\\_of\\_vessel\\_strike\\_avoidance\\_february\\_2008.pdf](http://sero.nmfs.noaa.gov/protected_resources/section_7/guidance_docs/documents/copy_of_vessel_strike_avoidance_february_2008.pdf). Accessed July 2014.
- National Oceanic and Atmospheric Administration (NOAA). 2009. Tropical Cyclone Report – Hurricane Ike (AL092008). Available at: [http://www.nhc.noaa.gov/pdf/TCR-AL092008\\_Ike\\_3May10.pdf](http://www.nhc.noaa.gov/pdf/TCR-AL092008_Ike_3May10.pdf). Accessed July 2014.
- National Oceanic and Atmospheric Administration (NOAA). 2013a. Historical Hurricane Tracks. Available at: <http://www.csc.noaa.gov/hurricanes/#app=7490&3e3d-selectedIndex=1>. Accessed July 2014.
- National Oceanic and Atmospheric Administration (NOAA). 2013b. National Climatic Data Center – Storm Event Database. Available at: <http://www.ncdc.noaa.gov/stormevents/choosedates.jsp?statefips=48%2CTEXAS>. Accessed July 2014.
- National Oceanic and Atmospheric Administration (NOAA). 2013c. Essential Habitat Mapper. Available at: <http://www.habitat.noaa.gov/protection/efh/efhmapper>. Accessed October 2013.
- National Oceanic and Atmospheric Administration (NOAA). 2014a. National Weather Service National Hurricane Center. Storm Surge Overview. Available at: <http://www.nhc.noaa.gov/surge/>. Accessed July 2014.
- National Oceanic and Atmospheric Administration (NOAA). 2014b. Fishwatch U.S. Seafood Facts – Brown Shrimp. Available at: [http://www.fishwatch.gov/seafood\\_profiles/species/shrimp/species\\_pages/brown\\_shrimp.htm](http://www.fishwatch.gov/seafood_profiles/species/shrimp/species_pages/brown_shrimp.htm). Accessed July 2014.
- National Oceanic and Atmospheric Administration (NOAA). 2014c. Fishwatch U.S. Seafood Facts – White Shrimp. Available at: [http://www.fishwatch.gov/seafood\\_profiles/species/shrimp/species\\_pages/white\\_shrimp.htm](http://www.fishwatch.gov/seafood_profiles/species/shrimp/species_pages/white_shrimp.htm). Accessed July 2014.
- National Oceanic and Atmospheric Administration (NOAA). 2014d. Green Sea Turtle (*Chelonia mydas*). Available at: <http://www.nmfs.noaa.gov/pr/species/turtles/green.htm>. Accessed July 2014.
- National Oceanic and Atmospheric Administration (NOAA). 2014e. Hawksbill Sea Turtle (*Eretmochelys imbricata*). Available at: <http://www.nmfs.noaa.gov/pr/species/turtles/hawksbill.htm>. Accessed July 2014.



## APPENDIX L – REFERENCES

- National Oceanic and Atmospheric Administration (NOAA). 2014f. Kemp's Ridley Sea Turtle (*Lepidochelys kempii*). Available at: <http://www.nmfs.noaa.gov/pr/species/turtles/kempsridley.htm>. Accessed July 2014.
- National Oceanic and Atmospheric Administration (NOAA). 2014g. Leatherback Sea Turtle (*Dermochelys coriacea*). Available at: <http://www.nmfs.noaa.gov/pr/species/turtles/leatherback.htm>. Accessed July 2014.
- National Oceanic and Atmospheric Administration (NOAA). 2014h. Loggerhead Sea Turtle (*Caretta caretta*). Available at: <http://www.nmfs.noaa.gov/pr/species/turtles/loggerhead.htm>. Accessed July 2014.
- National Wildlife Federation (NWF). 2014. Alligator Snapping Turtle. Available at: <http://www.nwf.org/wildlife/wildlife-library/amphibians-reptiles-and-fish/alligator-snapping-turtle.aspx>. Accessed July 2014.
- Nationwide Environmental Title Research, LLC (NETR). 2013. EPA Environmental Hazard Site Locations. Available at: <http://environment.netronline.com/>. Accessed August 2014.
- Natural Science Research Laboratory (NSRL). 2014. Rafinesque's Big-eared Bat. Available at: <http://www.nsrll.ttu.edu/tmot1/plecrafi.htm>. Accessed July 2014.
- Nexant ChemSystems. 2004. Advances in LNG Technologies. (PERP [Process Evaluation/Research Planning] Report 03/04S10.) October.
- Perryman Group. 2012. The Socioeconomic Impact of Authorizing Exports of Liquefied Natural Gas from the Proposed Golden Pass Products LLC Facilities in Sabine Pass, Texas, on Business Activity in Jefferson County, the Surrounding Region, and the United States. Fossil Energy Docket No. FE12-156-LNG. Available at: [http://www.fossil.energy.gov/programs/gasregulation/authorizations/2012\\_applications/12\\_156\\_lng.pdf](http://www.fossil.energy.gov/programs/gasregulation/authorizations/2012_applications/12_156_lng.pdf).
- Pierorazio, A. J., K. Thomas, Q. A. Baker, and D. E. Ketchum. 2005. An Update to the Baker–Strehlow–Tang Vapor Cloud Explosion Prediction. Methodology Flame Speed Table, Process Safety Progress. (Vol.24, No.1.) March.
- Pipeline and Hazardous Materials Safety Administration (PHMSA). 2014. Significant Pipeline Incidents, National Gas Transmission: Significant Incidents Summary Statistics: 1994–2013. Available at: [http://primis.phmsa.dot.gov/comm/reports/safety/SigPSIDet\\_1994\\_2013\\_US.html?nocache=8649#\\_ngtrans](http://primis.phmsa.dot.gov/comm/reports/safety/SigPSIDet_1994_2013_US.html?nocache=8649#_ngtrans).
- Renken, R. 1998. Arkansas, Louisiana, Mississippi, in Groundwater Atlas of the United States. (U.S. Geological Survey HA 730-F.) Available at: [http://capp.water.usgs.gov/gwa/ch\\_f/index.html](http://capp.water.usgs.gov/gwa/ch_f/index.html). Accessed August 5, 2014.
- Sabine Neches Navigation District (SNND). 2014. The Waterway. Available at: <http://navigationdistrict.org/about/the-waterway>. Accessed August 5, 2014.
- Sabine River Authority of Texas (SRAT). 1999. Comprehensive Sabine Watershed Management Plan. (SRA96425.) Available at: [http://www.sratx.org/srwmp/comprehensive\\_plan/final\\_report/pdf/CSWMP.pdf](http://www.sratx.org/srwmp/comprehensive_plan/final_report/pdf/CSWMP.pdf). Accessed August 5, 2014.

## APPENDIX L – REFERENCES

- Scott, T., J. Hughey, and J. Picklesimer. 2009a. Cultural Resource Management Survey of the Golden Pass LNG Pipeline Project in Jefferson, Orange, and Newton Counties, Texas. Report prepared for AMEC Paragon, Inc., Houston and Golden Pass Pipeline, LLC. FERC Docket No. CP04-400-000, -001, -002. HRA Gray & Pape, LLC, Houston.
- Scott, T., J. Hughey, and J. Picklesimer. 2009b. Cultural Resource Management Survey of the Golden Pass Pipeline Project in Calcasieu Parish, Louisiana. Report prepared for AMEC Paragon, Inc., Houston and Golden Pass Pipeline, LLC. FERC Docket No. CP04-400-000, -001, -002. HRA Gray & Pape, LLC, Houston.
- Scott, T. 2013a. Assessment of Property Proposed for a Terminal Station in Jefferson County, Texas in Association with the Proposed Golden Pass Export Project. Draft report prepared for exp Energy Services, Inc., Houston. HRA Gray & Pape, LLC, Houston.
- Scott, T. 2013b. Assessment of Property Proposed for the Golden Pass North Loop Pipeline in Calcasieu Parish, Louisiana in Association with the Proposed Golden Pass Export Project. Draft report prepared for exp Energy Services, Inc., Houston. HRA Gray & Pape, LLC, Houston.
- Scott, T. 2013c. Intensive Pedestrian Cultural Resources Survey of the Proposed HPL Texoma Compressor Station for the Golden Pass GPX Project in Orange County, Texas. Draft report prepared for exp Energy Services, Inc., Houston. HRA Gray & Pape, LLC, Houston.
- Scott, T. 2013d. Negative Findings Report for a Phase I Cultural Resources Survey of Three Proposed Compressor Station Areas for the Golden Pass GPX Project in Calcasieu Parish, Louisiana. Draft report prepared for exp Energy Services, Inc., Houston. HRA Gray & Pape, LLC, Houston.
- Society of Fire Protection Engineers. 2008. Sfppe Handbook of Fire Protection Engineering. 4<sup>th</sup> edition. National Fire Protection Association.
- Stevenson, D. A., and R. P. McCulloh. 2001. Earthquakes in Louisiana. Public Information Series 7. Louisiana Geological Survey, Baton Rouge, Louisiana, USA. Available at: <http://www.lgs.lsu.edu/deploy/uploads/7earthquakes.pdf>. Accessed July 2014.
- Sutherland. 2014. Magnolia LNG Signs Tolling Agreement Term Sheet with AES Latin American Development. LNW Law Blog. Available at: <http://www.lnglawblog.com/2014/03/magnolia-lng-signs-tolling-agreement-term-sheet-with-aes-latin-american-development/>.
- Tax-Rates.org. 2014. 2014 Texas Sales Tax By County. Available at: <http://www.tax-rates.org/texas/sales-tax-by-county>. Accessed September 28, 2014.
- Texas Administrative Code (TAC). 2014. Title 30 Environmental Quality - Air Permitting. Available at: <http://www.tceq.state.tx.us/permitting/air/rules/state/statehp.html>.
- Texas Coastal Management Program (TCMP). 2012. 2012 Annual Report. Available at: <http://www.glo.texas.gov/what-we-do/caring-for-the-coast/publications/2012-cmp-annual-report.pdf>. Accessed on August 6, 2014.
- Texas Commission on Environmental Quality (TCEQ). 2004. State Water Quality Certification of Section 404 Permits. Available at: <https://www.tceq.texas.gov/assets/public/permitting/assess/401cert/401cov.pdf>. Accessed September 23, 2014.

## APPENDIX L – REFERENCES

- Texas Commission on Environmental Quality (TCEQ). 2010. Groundwater Classification. TCEQ Regulatory Guidance. Remediation Division. RG-366/TRRP-8. Revised March 2010. Available at: [http://www.tceq.texas.gov/publications/rg/rg-366\\_trrp\\_08.html](http://www.tceq.texas.gov/publications/rg/rg-366_trrp_08.html). Accessed August 5, 2014.
- Texas Commission on Environmental Quality (TCEQ). 2012a. 2012 Texas Integrated Report – Texas 303(d) List (Category 5). Available at: [http://www.tceq.texas.gov/assets/public/waterquality/swqm/assess/12twqi/2012\\_303d.pdf](http://www.tceq.texas.gov/assets/public/waterquality/swqm/assess/12twqi/2012_303d.pdf). Accessed August 5, 2014.
- Texas Commission on Environmental Quality (TCEQ). 2012b. 2012 Texas Integrated Report of Surface Water Quality for Clean Water Act Sections 305(b) and 303(d). Available at: <http://www.tceq.texas.gov/waterquality/assessment/12twqi/12twqi>. Accessed August 5, 2014.
- Texas Commission on Environmental Quality (TCEQ). 2012c. Chapter 307 – Texas Surface Water Quality Standards. Rule Project No. 2012-001-307-OW. Available at: [http://www.tceq.texas.gov/assets/public/legal/rules/rule\\_lib/proposals/12001307\\_pro.pdf](http://www.tceq.texas.gov/assets/public/legal/rules/rule_lib/proposals/12001307_pro.pdf). Accessed August 5, 2014.
- Texas Commission on Environmental Quality (TCEQ). 2013a. Priority Groundwater Management Areas (PGMAs). Map. Available at: [http://www.tceq.state.tx.us/assets/public/permitting/watersupply/groundwater/maps/pgma\\_areas.pdf](http://www.tceq.state.tx.us/assets/public/permitting/watersupply/groundwater/maps/pgma_areas.pdf). Accessed August 5, 2014.
- Texas Committee on Environmental Quality (TCEQ). 2013b. Understanding General Conformity in Texas. Available at: <https://www.tceq.texas.gov/airquality/mobilesource/gc.html>.
- Texas Commission on Environmental Quality (TCEQ). 2014a. What is a Groundwater Conservation District (GCD)? Available at: [http://www.tceq.state.tx.us/assets/public/permitting/watersupply/groundwater/maps/gcd\\_text.pdf](http://www.tceq.state.tx.us/assets/public/permitting/watersupply/groundwater/maps/gcd_text.pdf). Accessed August 5, 2014.
- Texas Commission on Environmental Quality (TCEQ). 2014b. Priority Groundwater Management Areas. Available at: <http://www.tceq.state.tx.us/groundwater/groundwater/pgma.html>. Accessed August 5, 2014.
- Texas Commission on Environmental Quality (TCEQ). 2014c. Texas Groundwater Conservation Districts (August 2014). Map. Available at: <http://www.tceq.state.tx.us/assets/public/permitting/watersupply/groundwater/maps/gcdmap.pdf>. Accessed August 5, 2014.
- Texas Commission on Environmental Quality (TCEQ). 2014d. 401 Certification Reviews. Available at: [https://www.tceq.texas.gov/permitting/401certification/401certification\\_definition.html](https://www.tceq.texas.gov/permitting/401certification/401certification_definition.html). Accessed August 6, 2014.
- Texas Committee on Environmental Quality (TCEQ). 2014e. Geographical Texas Air Monitoring. Available at: <http://tceq4apmgwebp1.tceq.texas.gov:8080/geotam/>.
- Texas Department of State Health Services. 2012. Hospital Characteristics 2012. Available at: <http://www.dshs.state.tx.us/THCIC/Publications/Hospitals/IQIRReport/IQIRReport.shtm>. Accessed September 28, 2014.
- Texas General Land Office (GLO). 2013. Texas Critical Erosion Areas. Available at: <http://koordinates.com/layer/821-texas-critical-erosion-areas/>. Accessed July 2014.

## APPENDIX L – REFERENCES

- Texas Parks and Wildlife Department (TPWD). 1999. Vegetation Layers. Available at: [http://www.tpwd.state.tx.us/publications/pwdpubs/media/pwd\\_lf\\_k0700\\_0167e.pdf](http://www.tpwd.state.tx.us/publications/pwdpubs/media/pwd_lf_k0700_0167e.pdf). Accessed July 2014.
- Texas Parks and Wildlife Department (TPWD). 2005. Texas Wildlife Identification Guide. Available at: [http://www.tpwd.state.tx.us/publications/pwdpubs/media/pwd\\_bk\\_k0700\\_0517.pdf](http://www.tpwd.state.tx.us/publications/pwdpubs/media/pwd_bk_k0700_0517.pdf). Accessed July 2014.
- Texas Parks and Wildlife Department (TPWD). 2013a. Water Planning Data for Region I (East Texas). Available at: [http://www.tpwd.state.tx.us/landwater/water/environconcerns/water\\_quality/sigsegs/regioni.phtml](http://www.tpwd.state.tx.us/landwater/water/environconcerns/water_quality/sigsegs/regioni.phtml). Accessed August 5, 2014.
- Texas Parks and Wildlife Department (TPWD). 2013b. Letter dated October 19, from Rebecca Hensley, Coastal Fisheries Division, to Kim Bose, FERC.
- Texas Parks and Wildlife Department (TPWD). 2013c. Rare, Threatened, and Endangered Species of Texas. Available at: <http://www.tpwd.state.tx.us/gis/ris/es/>. Accessed October 2013.
- Texas Parks and Wildlife Department (TPWD). 2014a. Red Drum (*Sciaenops ocellatus*). Available at: <http://www.tpwd.state.tx.us/huntwild/wild/species/reddrum/>. Accessed July 2014.
- Texas Parks and Wildlife Department (TPWD). 2014b. Wildlife Fact Sheets. Available at: <http://www.tpwd.state.tx.us/huntwild/wild/species/>. Accessed July 2014.
- Texas Parks and Wildlife Department (TPWD). 2014c. Piping Plover (*Charadrius melodus*). Available at: <http://www.tpwd.state.tx.us/huntwild/wild/species/piplover/>. Accessed July 2014.
- Texas Parks and Wildlife Department (TPWD). 2014d. American Alligator (*Alligator mississippiensis*). Available at: <http://www.tpwd.state.tx.us/huntwild/wild/species/americanalligator/>. Accessed July 2014.
- Texas Parks and Wildlife Department (TPWD). 2014e. Peregrine Falcon (*Falco peregrinus*). Available at: [http://www.tpwd.state.tx.us/publications/pwdpubs/media/pwd\\_bk\\_w7000\\_0013\\_peregrine\\_falcon.pdf](http://www.tpwd.state.tx.us/publications/pwdpubs/media/pwd_bk_w7000_0013_peregrine_falcon.pdf). Accessed July 2014.
- Texas Parks and Wildlife Department (TPWD). 2014f. Reddish Egret (*Egretta rufescens*). Available at: <http://www.tpwd.state.tx.us/huntwild/wild/species/reddishegret/>. Accessed July 2014.
- Texas Parks and Wildlife Department (TPWD). 2014g. Swallow-tailed Kite (*Elanoides forficatus*). Available at: [http://www.tpwd.state.tx.us/huntwild/wild/birding/swallow\\_tailed\\_kite/interest\\_description\\_location/](http://www.tpwd.state.tx.us/huntwild/wild/birding/swallow_tailed_kite/interest_description_location/). Accessed July 2014.
- Texas Parks and Wildlife Department (TPWD). 2014h. White-faced Ibis (*Plegadis chihi*). Available at: <http://www.tpwd.state.tx.us/huntwild/wild/species/ibis/>. Accessed July 2014.
- Texas Parks and Wildlife Department (TPWD). 2014i. Rafinesque's Big-eared Bat (*Corynorhinus rafinesquii*). Available at: <http://www.tpwd.state.tx.us/huntwild/wild/species/rafinesque/>. Accessed July 2014.

## APPENDIX L – REFERENCES

- Texas Parks and Wildlife Department (TPWD). 2014j. Texas Diamondback Terrapin (*Malaclemys terrapin littoralis*). Available at: <http://www.tpwd.state.tx.us/huntwild/wild/species/terrapin/>. Accessed July 2014.
- Texas Parks and Wildlife Department (TPWD). 2014k. Gulf Salt Marsh Snake (*Nerodia clarkii*). Available at: <http://www.tpwd.state.tx.us/huntwild/wild/species/gulfsnake/>. Accessed July 2014.
- Texas Parks and Wildlife Department (TPWD). 2014l. Timber Rattlesnake (*Crotalus horridus*). Available at: <http://www.tpwd.state.tx.us/huntwild/wild/species/timberrattlesnake/>. Accessed July 2014.
- Texas Water Development Board (TWDB). 2006. Aquifers of the Gulf Coast of Texas. Report 365. Available at: [https://www.twdb.state.tx.us/publications/reports/numbered\\_reports/doc/R365/R365\\_Composite.pdf](https://www.twdb.state.tx.us/publications/reports/numbered_reports/doc/R365/R365_Composite.pdf). Accessed August 5, 2014.
- Texas Water Development Board (TWDB). 2012. 2012 State Water Plan. Available at: <http://www.twdb.state.tx.us/waterplanning/swp/2012/index.asp>. Accessed January 2014.
- Texas Water Development Board (TWDB). 2013. TWDB Well Location Grid. Available at: <http://www.twdb.state.tx.us/mapping/gisdata.asp>. Accessed August 5, 2014.
- Texas Water Development Board (TWDB). 2014a. Texas Aquifers. Available at: <http://www.twdb.state.tx.us/groundwater/aquifer/>. Accessed August 5, 2014.
- Texas Water Development Board (TWDB). 2014b. Major Aquifers. Map. Available at: <http://www.twdb.state.tx.us/groundwater/aquifer/major.asp>. Accessed August 5, 2014.
- Texas Water Development Board (TWDB). 2014c. Minor Aquifers. Map. Available at: <http://www.twdb.state.tx.us/groundwater/aquifer/minor.asp>. Accessed August 5, 2014.
- Texas Water Development Board (TWDB). 2014d. Gulf Coast Aquifer. Available at: <http://www.twdb.texas.gov/groundwater/aquifer/majors/gulf-coast.asp>. Accessed August 5, 2014.
- Texas Water Development Board (TWDB). 2014e. Groundwater Conservation Districts of Texas. Map. Available at: [http://www.twdb.state.tx.us/mapping/doc/maps/GCDs\\_8x11.pdf](http://www.twdb.state.tx.us/mapping/doc/maps/GCDs_8x11.pdf). Accessed August 5, 2014.
- Trinity Consultants (TC). 2014. Ozone Impact Assessment Report, Golden Pass Products LNG Export Project. July 9.
- Tuttle, M. C. 2014. Marine Archaeological Survey exemption at the Golden Pass LNG Terminal Project, Jefferson County, Texas. Letter report prepared for Golden Pass Pipeline, LLC. HRA Gray & Pape, LLC., Houston.
- University of Texas at Austin Institute for Geophysics. 2014. Texas Earthquakes. Available at: <http://www.ig.utexas.edu/research/seismology/TXEQ/index.html>. Accessed July 2014.
- URS Corporation. 2005. Golden Pass LNG Terminal Project, Dredge Material Evaluation for Beneficial Use – Pintail Flats. Report prepared for Golden Pass LNG Terminal LP, April 2005.

## APPENDIX L – REFERENCES

- USA Cops. 2014. Available at: <http://www.usacops.com/>. Accessed September 28, 2014.
- USA Fire and Rescue. 2014. Available at: <http://www.usafireandrescue.com/>. Accessed September 28, 2014.
- U.S. Army Corps of Engineers (COE). 2012a. Sabine-Neches Waterway, TX. Fact Sheet. Available at: <http://www.swd.usace.army.mil/Portals/42/docs/civilworks/Fact%20Sheets/Galveston/FY13%20SNWW,%20TX.pdf>. Accessed August 5, 2014.
- U.S. Army Corp of Engineers (COE). 2012b. Sabine-Neches Waterway, TX – Fact Sheet as of February 21, 2012. Available at: <http://www.swd.usace.army.mil/Portals/42/docs/civilworks/Fact%20Sheets/Galveston/FY13%20SNWW,%20TX.pdf>. Accessed October 2013.
- U.S. Army Corps of Engineers (COE). 2013. Waterborne Commerce Statistics Center. 2013 Waterborne Commerce of the United States. Part 2. Available at: [http://www.navigationdatacenter.us/wsc/webpub13/Part2\\_WWYs\\_tonsbyTT\\_Dr\\_Yr\\_commCY2013-2009.htm](http://www.navigationdatacenter.us/wsc/webpub13/Part2_WWYs_tonsbyTT_Dr_Yr_commCY2013-2009.htm). Accessed August 21, 2015.
- U.S. Army Corps of Engineers (COE). 2014. New Orleans District. Coastal Use Permit by Louisiana Coastal Management Division. Available at: <http://www.mvn.usace.army.mil/Missions/Regulatory/Permits/WheretosubmitYourPermitApplicationDrawing.aspx>. Accessed August 6, 2014.
- U.S. Census Bureau. 2000. 2000 Census. Available at: <http://www.census.gov/main/www/cen2000.html?>
- U.S. Census Bureau. 2010. 2010 Census. Available at: <http://www.census.gov/2010census/>.
- U.S. Census Bureau. 2012. American Community Survey. 2008–2012 American Community Survey 5-year estimates. Available at: <http://www.census.gov/programs-surveys/acs/>.
- U.S. Census Bureau. 2013. American Community Survey. 2009–2013 American Community Survey 5-year estimates. Available at: <http://www.census.gov/programs-surveys/acs/>.
- U.S. Department of Agriculture (USDA). 2015. Introduced, Invasive, and Noxious Plants. Available at: <http://plants.usda.gov/java/noxComposite>. Accessed August 24, 2015.
- U.S. Department of Agriculture Natural Resources Conservation Service (NRCS). 1988. Soil Survey of Calcasieu Parish, Louisiana. Available at: [http://www.nrcs.usda.gov/Internet/FSE\\_MANUSCRIPTS/louisiana/LA019/0/calcasieu.pdf](http://www.nrcs.usda.gov/Internet/FSE_MANUSCRIPTS/louisiana/LA019/0/calcasieu.pdf). Accessed August 2014.
- U.S. Department of Agriculture Natural Resources Conservation Service (NRCS). 1996. Soil Survey of Jefferson and Orange Counties, Texas. Available at: [http://www.nrcs.usda.gov/Internet/FSE\\_MANUSCRIPTS/texas/TX623/0/Manuscript.pdf](http://www.nrcs.usda.gov/Internet/FSE_MANUSCRIPTS/texas/TX623/0/Manuscript.pdf). Accessed August 2014.
- U.S. Department of Agriculture Natural Resources Conservation Service (NRCS). 2012a. Ecological and Interpretive Groups. Available at: [http://www.nrcs.usda.gov/wps/portal/nrcs/detail/soils/survey/geo/?cid=nrcs142p2\\_054226#02](http://www.nrcs.usda.gov/wps/portal/nrcs/detail/soils/survey/geo/?cid=nrcs142p2_054226#02). Accessed August 2014.

## APPENDIX L – REFERENCES

- U.S. Department of Agriculture Natural Resources Conservation Service (NRCS). 2012b. Hydric Soils - Introduction. Available at: [http://www.nrcs.usda.gov/wps/portal/nrcs/detail/soils/use/hydric/?cid=nrcs142p2\\_053961](http://www.nrcs.usda.gov/wps/portal/nrcs/detail/soils/use/hydric/?cid=nrcs142p2_053961). Accessed August 2014.
- U.S. Department of Agriculture Natural Resources Conservation Service (NRCS). 2014a. Soil Survey Geographic (SSURGO) Database. Available at: <http://websoilsurvey.nrcs.usda.gov/>. Accessed August 2014.
- U.S. Department of Agriculture Natural Resources Conservation Service (NRCS). 2014b. Official Soil Series Descriptions (OSDs) with series extent mapping capabilities. Available at: <https://soilseries.sc.egov.usda.gov/>. Accessed August 2014.
- U.S. Department of Agriculture Natural Resources Conservation Service (NRCS). 2014c. Keys to Soil Taxonomy. Soil Survey Staff. Twelfth Edition.
- U.S. Department of Energy (DOE). 2013. Lake Charles Carbon Capture and Sequestration Project, Final Environmental Impact Statement. (DOE/EIS-0464.) November.
- U.S. Department of Labor. 2013. Bureau of Labor Statistics. Available at: <http://www.bls.gov/data/>.
- U.S. District Court for the Eastern District of Louisiana (USDC). 2002. 2002 Consent Decree 303(d) List. Available at: <http://www.deq.louisiana.gov/portal/Portals/0/technology/tmdl/ConsentDecree.pdf>. Accessed September 27, 2014.
- U.S. Environmental Protection Agency (EPA). 1978. Protective Noise Levels. (USEPA 550/9-79-100.) Available at: <http://nepis.epa.gov>.
- U.S. Environmental Protection Agency (EPA). 1999. Consideration of Cumulative Impacts in EPA Review of NEPA Documents. Memorandum from U.S. EPA, Office of Federal Activities (2252A). (EPA 315-R-99-002/May.)
- U.S. Environmental Protection Agency (EPA). 2004. The Incidence of Sediment Contamination in Surface Waters of the United States, National Sediment Quality Survey: Second Edition. November 2004. Available at: <http://water.epa.gov/polwaste/sediments/cs/upload/nsqs2ed-complete-2.pdf>. Accessed August 5, 2014.
- U.S. Environmental Protection Agency. 2007. Guidance on the Use of Models and Other Analyses for Demonstrating Attainment of Air Quality Goals for Ozone, PM<sub>2.5</sub>, and Regional Haze. Office of Air Quality Planning and Standards. (EPA-454/B-07-002.) Research Triangle Park, North Carolina. April. Available at: <http://www.epa.gov/scram001/guidance/guide/final-03-pm-rh-guidance.pdf>.
- U.S. Environmental Protection Agency (EPA). 2008. Sole Source Aquifers. Chicot Aquifer System. Available at: [http://www.epa.gov/region6/water/swp/ssa/maps/ssa\\_chicot.pdf](http://www.epa.gov/region6/water/swp/ssa/maps/ssa_chicot.pdf). Accessed August 5, 2014.
- U.S. Environmental Protection Agency (EPA). 2009. Current Methodologies in Preparing Mobile Source Port-Related Emission Inventories. Final Report. April. Available at: <http://www.epa.gov/sectors/sectorinfo/sectorprofiles/ports/ports-emission-inv-april09.pdf>.

## APPENDIX L – REFERENCES

- U.S. Environmental Protection Agency (EPA). 2010. Memorandum from Stephen D. Page to Regional Air Division Directors titled, “Guidance Concerning the Implementation of the 1-hour NO<sub>2</sub> NAAQS for the Prevention of Significant Deterioration Program.” June 28. Available at: [http://yosemite.epa.gov/oa/EAB\\_Web\\_Docket.nsf/Filings%20By%20Appeal%20Number/A12C3AF182585C8D852579530068A201/\\$File/Ex.%205...45.pdf](http://yosemite.epa.gov/oa/EAB_Web_Docket.nsf/Filings%20By%20Appeal%20Number/A12C3AF182585C8D852579530068A201/$File/Ex.%205...45.pdf).
- U.S. Environmental Protection Agency (EPA). 2011a. Environmental Justice Frequently Asked Questions. Available at: <http://www.epa.gov/compliance/ej/resources/faqs/index.html>.
- U.S. Environmental Protection Agency (EPA). 2011b. Memorandum from Tyler Fox to Regional Air Division Directors, titled “Additional Clarification Regarding Application of Appendix W Modeling Guidance for the 1-hour NO<sub>2</sub> National Ambient Air Quality Standard.” March 1. Available at: [http://www.epa.gov/region07/air/nsr/nsrmemos/appwno2\\_2.pdf](http://www.epa.gov/region07/air/nsr/nsrmemos/appwno2_2.pdf).
- U.S. Environmental Protection Agency (EPA). 2012a. Sole Source Aquifer Protection Program. Available at: <http://water.epa.gov/infrastructure/drinkingwater/sourcewater/protection/solesourceaquifer.cfm>. Accessed August 5, 2014.
- U.S. Environmental Protection Agency (EPA). 2012b. Designated Sole Source Aquifers in Region VI. Available at: [http://www.epa.gov/safewater/sourcewater/pubs/qrg\\_ssamap\\_reg6.pdf](http://www.epa.gov/safewater/sourcewater/pubs/qrg_ssamap_reg6.pdf). Accessed August 5, 2014.
- U.S. Environmental Protection Agency (EPA). 2012c. Section 404 of the Clean Water Act: How Wetlands Are Defined and Identified. Available at: <http://water.epa.gov/type/wetlands/outreach/fact11.cfm>. Accessed August 6, 2014.
- U.S. Environmental Protection Agency (EPA). 2012d. National Ambient Air Quality Standards. Available at: <http://epa.gov/air/criteria.html>.
- U.S. Environmental Protection Agency (EPA). 2013a. Surf Your Watershed. Available at: <http://cfpub.epa.gov/surf/locate/index.cfm>. Accessed September 4, 2014.
- U.S. Environmental Protection Agency (EPA). 2013b. Water: After the Storm – Weather. Available at: <http://water.epa.gov/action/weatherchannel/stormwater.cfm>. Accessed September 29, 2014.
- U.S. Environmental Protection Agency (EPA). 2013c. Air Data. Monitor Values Report. Available at: [http://www.epa.gov/airquality/airdata/ad\\_rep\\_mon.html](http://www.epa.gov/airquality/airdata/ad_rep_mon.html).
- U.S. Environmental Protection Agency (EPA). 2013d. Acute Exposure Guideline Levels. Available at: <http://www.epa.gov/oppt/aegl/pubs/chemlist.htm>. December 3.
- U.S. Environmental Protection Agency (EPA). 2014a. Species Profile: Bald Eagle. Available at: [http://www.epa.gov/housatonic/thesite/restofriver/reports/final\\_era/B%20-%20Focus%20Species%20Profiles/EcoRiskProfile\\_bald\\_eagle.pdf](http://www.epa.gov/housatonic/thesite/restofriver/reports/final_era/B%20-%20Focus%20Species%20Profiles/EcoRiskProfile_bald_eagle.pdf). Accessed July 2014.
- U.S. Environmental Protection Agency (EPA). 2014b. General Conformity. De Minimis Levels. Available at: <http://www.epa.gov/oaqps001/genconform/deminimis.html>.
- U.S. Environmental Protection Agency (EPA). 2014c. Supreme Court of the United States. Syllabus. Utility Air Regulatory Group v. Environmental Protection Agency et al. Available at: [http://www.supremecourt.gov/opinions/13pdf/12-1146\\_4g18.pdf](http://www.supremecourt.gov/opinions/13pdf/12-1146_4g18.pdf).



## APPENDIX L – REFERENCES

- U.S. Environmental Protection Agency (EPA). 2014d. July 24, 2014 Memorandum. Next Steps and Preliminary Views on the Application of Clean Air Act Permitting Programs to Greenhouse Gases Following the Supreme Court's Decision in Utility Air Regulatory Group v. EPA. Available at: <http://www.jacksonkelly.com/pdf/Memo%20JMCCabe%20and%20CGiles%20to%20RAs.pdf>.
- U.S. Fish and Wildlife Service (FWS). 2006. Peregrine Falcon. Available at: <http://www.fws.gov/endangered/esa-library/pdf/peregrinefactsheet.pdf>. Accessed July 2014.
- U.S. Fish and Wildlife Service (FWS). 2007. National Bald Eagle Management Guidelines. Available at: <http://www.fws.gov/northeast/EcologicalServices/eaglenationalguide.html>. Accessed August 27, 2015.
- U.S. Fish and Wildlife Service (FWS). 2008b. Birds of Conservation Concern. Available at: <http://www.fws.gov/migratorybirds/CurrentBirdIssues/Management/BCC.html>. Accessed September 2014.
- U.S. Fish and Wildlife Service (FWS). 2013a. Letter dated March from Edith Erfling, Field Supervisor.
- U.S. Fish and Wildlife Service (FWS). 2013b. Letter dated November 7, from Brad Rieck, Deputy Field Supervisor, to Kim Bose, FERC.
- U.S. Fish and Wildlife Service (FWS). 2013c. Letter dated November 14, from Edith Erfling, Field Supervisor, to Kim Bose, FERC.
- U.S. Fish and Wildlife Service (FWS). 2014a. Letter dated July 3, from Edith Erfling, to Kim Bose, FERC.
- U.S. Fish and Wildlife Service (FWS). 2014b. Sprague's Pipit Conservation Plan. Available at: <http://www.fws.gov/mountain-prairie/species/birds/spraguespipit/SpraguesJS2010r4.pdf>. Accessed July 2014.
- U.S. Fish and Wildlife Service (FWS). 2014c. Bald and Golden Eagles. Available at: <http://www.fws.gov/migratorybirds/baldeagle.htm>. Accessed July 2014.
- U.S. Fish and Wildlife Service (FWS). 2014d. Wood Stork (*Mycteria americana*). Available at: <http://ecos.fws.gov/speciesProfile/profile/speciesProfile.action?sPCODE=B06O>. Accessed July 2014.
- U.S. Fish and Wildlife Service (FWS). 2014e. Alligator Snapping Turtle (*Macrochelys temminckii*). Available at: <http://ecos.fws.gov/speciesProfile/profile/speciesProfile.action?sPCODE=C045>. Accessed July 2014.
- U.S. Geological Survey (USGS). 1987. Development of Ground-water Resources in the Orange County Area, Texas and Louisiana, 1980 – Spring of 1985. (Water Resources Investigations Report 87-4158.) Available at: <http://pubs.usgs.gov/wri/1987/4158/report.pdf>. Accessed August 5, 2014.
- U.S. Geological Survey (USGS). 1998. Distribution of Saltwater in the Chicot Aquifer System of Southwestern Louisiana, 1995–96. (Water Resources Technical Report No. 66.) Available at: <http://la.water.usgs.gov/publications/pdfs/TR66.pdf>. Accessed August 5, 2014.

## APPENDIX L – REFERENCES

- U.S. Geological Survey (USGS). 1999. Quality of Water in Domestic Wells in the Chicot Aquifer System of Southwestern Louisiana. Available at: <http://la.water.usgs.gov/proposals/chctqw.html>. Accessed August 5, 2014.
- U.S. Geological Survey (USGS). 2003. A Tapestry of Time and Terrain. Available at: <http://nationalatlas.gov/tapestry/physiogr/physio.html>. Accessed July 2014.
- U.S. Geological Survey (USGS). 2004. Shallow Sands and Thickness Data for the Chicot Aquifer System Surficial Confining Unit, Southwestern Louisiana. Available at: <http://la.water.usgs.gov/publications/pdfs/BR22.pdf>. Accessed August 5, 2014.
- U.S. Geological Survey (USGS). 2005. Preliminary integrated geologic map databases for the United States: Central States. (Open-File Report 2005-1351.) Available at: <http://mrdata.usgs.gov/geology/state/state.php?state=TX>. Accessed October 2014.
- U.S. Geological Survey (USGS). 2010. Status of the Chicot Aquifer System in Southwestern Louisiana with Emphasis on the Lake Peigneur Area. August 4. Available at: <http://senate.la.gov/mills/Topics/2011/JECH/aquafier.pdf>. Accessed August 5, 2014.
- U.S. Geological Survey (USGS). 2013. 2014 Preliminary Hazard Maps. Available at: <http://earthquake.usgs.gov/hazards/2014prelim/>. Accessed July 2014.
- U.S. Geological Survey (USGS). 2014. Landslide Hazards Program: Frequently Asked Questions. Available at: <http://www.usgs.gov/faq/?q=taxonomy/term/9752>. Accessed July 2014.
- U.S. Global Change Research Program (USGCRP). 2014. Jerry M. Melillo, Terese (T. C.) Richmond, and Gary W. Yohe (Eds.). 2014: Climate Change Impacts in the United States: The Third National Climate Assessment. Available at: <http://nca2014.globalchange.gov/report>. Accessed August 24, 2015.
- Westgate, J. 2004. Lamar University. Personal communication regarding paleontological resources.
- Yellow Pages for Business. 2014. Campgrounds and Recreational Vehicle Parks. Available at: <http://www.yellowpages.com>.

**APPENDIX M**  
**List of Preparers**

## APPENDIX M – LIST OF PREPARERS

### Federal Energy Regulatory Commission

**Howard, Eric – Project Manager, *Project Description, Alternatives, Cultural Resources, Cumulative Impacts***

M.A., Anthropology, University of Tennessee, 1998

B.A., Anthropology, University of Tennessee, 1992

**Kerrigan, Jennifer – Deputy Project Manager, *Land Use, Socioeconomics***

M.S., Geology, West Virginia University, 1979

B.S., Geology, Marietta College, 1975

**Busch, Steven – *Reliability and Safety***

M.S., Environmental Engineering, University of Maryland, 2003

B.S., Mechanical Engineering, University of Maryland, 1999

**Glaze, James – *Geology, Soils***

B.S., Geology, California Lutheran University, 1975

**Johnson, Gertrude – *Air and Noise***

B.S., Mechanical Engineer, Virginia Commonwealth University, 2003

**Kochhar, Medha – *Water, Wetlands, Fish and Wildlife, Threatened and Endangered Species***

Ph.D., Plant Ecology, North Carolina State University, 1974

M.S., Botany, B.I.T.S., Pilani, India, 1968

B.S., Biology and Chemistry, University of Delhi, 1966

### Federal Energy Regulatory Commission Consultants

**Bachman, Robert, R.E. Bachman Consulting Structural Engineers**

M.S., Structural Engineering, University of California at Berkeley, 1968

B.S., Civil Engineering, University of California at Berkeley, 1967

**Bhushan, Kul, Group Delta Consultants, Inc.**

Ph.D., Geotechnical Engineering, Duke University, 1970

M.S., Highway Engineering, Panjab University, 1963

B.S., Civil Engineering, Panjab University, 1962

### Cardno

**Sechrist, Kim – Project Manager, *Social Science Task Lead***

M.S., Environmental Science, Towson University, 2006

B.S., Biology, McDaniel College, 2004

**Kicklighter, Wayne – Deputy Project Manager, *Project Scope Task Lead***

M.S. Ecology-Fisheries, San Diego State University, 1990

B.S. Biology, Memphis State University, 1987

**Brewer, John – *Biology Task Lead, Project Description, Cumulative Impacts***

M.S., Marine Biology, University of Alaska, Fairbanks, 2007

B.S., Wildlife Ecology and Conservation, Animal Science, University of Florida, 1997

## APPENDIX M – LIST OF PREPARERS

**DiSanto, Lavinia – *Physical Resources Task Lead***

B.A., Biological Sciences, University of Delaware, 1999

**Ferris, Jennifer – *Cultural Resources***

M.A., Anthropology, Washington State University, 2008

B.A., Anthropology, University of Washington, 2001

**Germain, Grace – *Air and Noise***

B.S., Civil Engineering, University of Santo Tomas, Philippines, 1983

**Hess, Jonathan – *Geology, Soils***

B.A., Environmental Geology, Millersville University, 2008

**Holmes, Sara – *Water, Wetlands, Vegetation***

B.S., Pre-Veterinary Science, West Virginia University, 2002

**Layton, Jackie – *Editor***

A.A.S., Architectural Engineering, Delaware Technical and Community College, 1992

**Lynn, Joan – *Editor***

**Metzler, Darcy – *Fish and Wildlife, Threatened and Endangered Species***

M.A., Marine Policy, Rosenstiel School of Marine and Atmospheric Sciences, University of Miami, 2009

B.S., Underwater Archeology, Indiana University, Bloomington, 2001

**Pahl, Oliver – *Socioeconomics***

B.S., Environmental Economics Policy and Management, minor in Natural Resource and Environmental Law and Policy, Oregon State University, 2003

**Staeger, William – *Alternatives, Reliability and Safety***

M.S., Oregon State University, 1974

B.A., Lafayette College, 1967

**Ward, Jennifer – *Social Sciences Task Lead, Land Use***

M.S., Resource Economics and Policy (Environmental), University of Maine, 2010

B.A., Mathematics, University of North Carolina – Asheville, 2001